

CLIFF

ISS.	AMEND	DATE
1	1st DRAWN	19/03/02
2	COLOUR VARIANTS	27/02/07
3	GREY VARIANT ADD	29/05/07
4	GOLD FM1012G ADD	29/01/10
5	COLOUR COVERS DEL	30/10/13

PART No.	COVER	PLATING
FM1012	BLACK (STD)	NICKEL
FM1012G	BLACK (STD)	GOLD

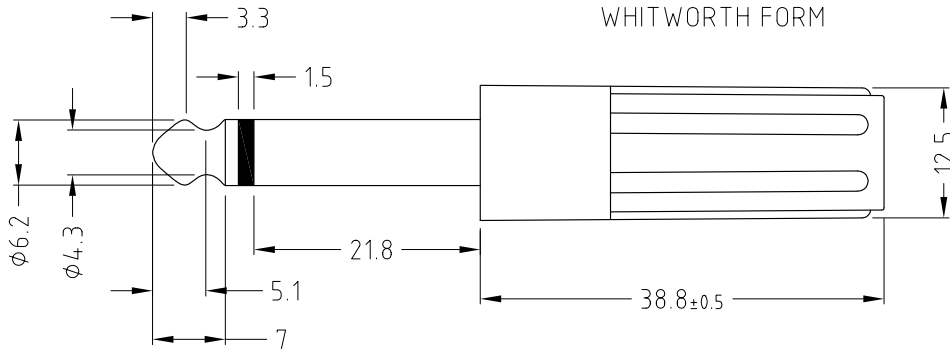
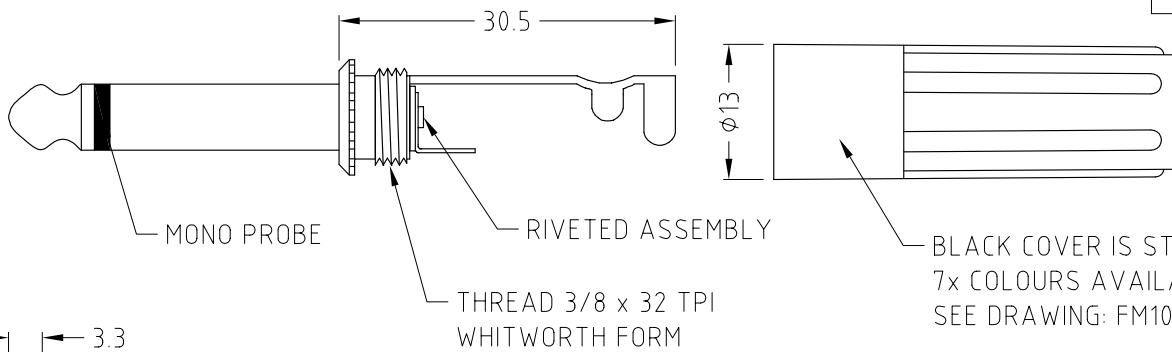

RoHS COMPLIANT
TOLERANCE
NO DEC. PLACE ± 0.50
1 DEC. PLACE ± 0.20
2 DEC. PLACE ± 0.10
HOLE Ø ± 0.10
ANGLES ± 1/2°
UNLESS OTHERWISE STATED

Cliff Electronic Components Ltd.
76 Holmethorpe Avenue, Holmethorpe Industrial Estate,
Redhill, Surrey, RH1 2PF, England, UK
Tel: 01737-771375 Fax: 01737-768012 Website: www.cliffuk.co.uk

DIMENSIONS IN MILLIMETERS UNLESS OTHERWISE STATED. WORK TO DIMENSIONS. REMOVE ALL BURRS. IF IN DOUBT ASK.

ANGLE PROJECTION:

DO NOT SCALE

MATERIAL: ABS / BRASS / STEEL / PHENOLIC

TITLE: 1/4" (6.35mm) MONO UNSCREENED JACK PLUG P2C

FINISH: AS MOULDED / NICKEL OR GOLD PLATED

DRWG. No. **FM1012**

DRAWN: C.A.M.J.

APPROVED: R.W.T.

FORM: A4DRWGH

THE CONTENTS OF THIS DOCUMENT MUST NOT BE COPIED OR DISCLOSED TO A 3rd PARTY WITHOUT WRITTEN PERMISSION OF CLIFF UK. © 2002