

BeagleBone LCD3 Cape Rev A1 System Reference Manual

Revision A1
June 20th, 2012



THIS DOCUMENT

This work is licensed under the Creative Commons Attribution-Share Alike 3.0 Unported License. To view a copy of this license, visit <http://creativecommons.org/licenses/by-sa/3.0/> or send a letter to Creative Commons, 171 Second Street, Suite 300, San Francisco, California, 94105, USA.

All derivative works are to be attributed to BeagleBoardtoys.com.

For more information, see <http://creativecommons.org/licenses/by-sa/3.0/>

For any questions, concerns, or issues submit them to support@beagleboardtoys.com

BEAGLEBONE LCD3 CAPE DESIGN

These design materials referred to in this document are ***NOT SUPPORTED*** and **DO NOT** constitute a reference design. Only “community” support is allowed via resources at Beagleboardtoys.com/support

THERE IS NO WARRANTY FOR THE DESIGN MATERIALS, TO THE EXTENT PERMITTED BY APPLICABLE LAW. EXCEPT WHEN OTHERWISE STATED IN WRITING THE COPYRIGHT HOLDERS AND/OR OTHER PARTIES PROVIDE THE DESIGN MATERIALS “AS IS” WITHOUT WARRANTY OF ANY KIND, EITHER EXPRESSED OR IMPLIED, INCLUDING, BUT NOT LIMITED TO, THE IMPLIED WARRANTIES OF MERCHANTABILITY AND

FITNESS FOR A PARTICULAR PURPOSE. THE ENTIRE RISK AS TO THE QUALITY AND PERFORMANCE OF THE DESIGN MATERIALS IS WITH YOU. SHOULD THE DESIGN MATERIALS PROVE DEFECTIVE, YOU ASSUME THE COST OF ALL NECESSARY SERVICING, REPAIR OR CORRECTION.

We mean it; these design materials may be totally unsuitable for any purposes.

BeagleBoardToys provides the enclosed product(s) under the following conditions:

This evaluation board/kit is intended for use for **ENGINEERING DEVELOPMENT, DEMONSTRATION, OR EVALUATION PURPOSES ONLY** and is not considered by BeagleBoardtoys.com to be a finished end-product fit for general consumer use. Persons handling the product(s) must have electronics training and observe good engineering practice standards. As such, the goods being provided are not intended to be complete in terms of required design-, marketing-, and/or manufacturing-related protective considerations, including product safety and environmental measures typically found in end products that incorporate such semiconductor components or circuit boards. This evaluation board/kit does not fall within the scope of the European Union directives regarding electromagnetic compatibility, restricted substances (RoHS), recycling (WEEE), FCC, CE or UL, and therefore may not meet the technical requirements of these directives or other related directives.

Should this evaluation board/kit not meet the specifications indicated in the User's Guide, the board/kit may be returned within **30 days** from the date of delivery for a full refund. THE FOREGOING WARRANTY IS THE EXCLUSIVE WARRANTY MADE BY SELLER TO BUYER AND IS IN LIEU OF ALL OTHER WARRANTIES, EXPRESSED, IMPLIED, OR STATUTORY, INCLUDING ANY WARRANTY OF MERCHANTABILITY OR FITNESS FOR ANY PARTICULAR PURPOSE.

The user assumes all responsibility and liability for proper and safe handling of the goods. Further, the user indemnifies BeagleBoardtoys.com from all claims arising from the handling or use of the goods. Due to the open construction of the product, it is the user's responsibility to take any and all appropriate precautions with regard to electrostatic discharge.

EXCEPT TO THE EXTENT OF THE INDEMNITY SET FORTH ABOVE, NEITHER PARTY SHALL BE LIABLE TO THE OTHER FOR ANY INDIRECT, SPECIAL, INCIDENTAL, OR CONSEQUENTIAL DAMAGES.

BeagleBoardtoys.com currently deals with a variety of customers for products, and therefore our arrangement with the user **is not exclusive**. BeagleBoardtoys.com assumes **no liability for applications assistance, customer product design, software performance, or infringement of patents or services described herein**.

Please read the User's Guide and, specifically, the Warnings and Restrictions notice in the User's Guide prior to handling the product. This notice contains important safety information about temperatures and voltages. For additional information on BeagleBoardtoys.com environmental and/or safety programs, please contact visit BeagleBoardtoys.com.

No license is granted under any patent right or other intellectual property right of BeagleBoard.org covering or relating to any machine, process, or combination in which such BeagleBoardtoys.com products or services might be or are used.

Mailing Address:

Beagleboardtoys.com
1380 Presidential Dr. #100
Richardson, TX 75081
U.S.A.



WARRANTY: *The BeagleBone LCD3 Cape is warranted against defects in materials and workmanship for a period of 90 days from purchase. This warranty does not cover any problems occurring as a result of improper use, modifications, exposure to water, excessive voltages, abuse, or accidents. All boards will be returned via standard mail if an issue is found. If no issue is found or express return is needed, the customer will pay all shipping costs.*

Before returning the board, please visit Beagleboardtoys.com/support

To return a defective board, please request an RMA at <http://www.beagleboardtoys.com/support/rma>



Table of Contents

FIGURES	7
TABLES	7
1.0 INTRODUCTION	9
2.0 CHANGE HISTORY	10
2.1 CHANGE HISTORY.....	10
3.0 BEAGLEBONE LCD3 CAPE OVERVIEW	11
3.1 DESCRIPTIONS.....	11
3.2 IN THE BOX	12
3.3 GETTING STARTED.....	12
3.4 REPAIRS	12
4.0 FEATURES AND SPECIFICATIONS	13
4.1 KEY COMPONENT LOCATIONS	14
4.2 LCD PANEL	16
4.3 INDICATORS	16
4.4 EXPANSION HEADER.....	16
4.5 SWITCHES	16
4.6 MECHANICAL SPECIFICATIONS	17
4.7 ELECTRICAL SPECIFICATIONS	17
5.0 SYSTEM ARCHITECTURE AND DESIGN	18
5.1 SYSTEM BLOCK DIAGRAM.....	18
5.2 LCD INTERFACE	20
5.2.1 <i>Expansion connectors</i>	20
5.2.2 <i>Non-Inverting Bus Transceiver</i>	20
5.2.3 <i>Touchscreen Interface</i>	21
5.3 LCD POWER SUPPLY	22
5.4 SERIAL PORT INTERFACE	22
5.5 EEPROM	23
5.5.1 <i>EEPROM Address</i>	23
5.5.2 <i>I2C Bus</i>	24
6.0 MECHANICAL INFORMATION	25
7.0 DESIGN MATERIALS	26



Figures

Figure 1.	The BeagleBone LCD3 Cape.....	11
Figure 3.	Key Components on top side	14
Figure 4.	Key Components on bottom side.....	15
Figure 5.	BeagleBone LCD3 Cape High Level Block Diagram	19
Figure 5.	LCD Signals at expansion connector J1	20
Figure 6.	LCD Signals buffered through U1	21
Figure 7.	BeagleBone LCD3 Backlight Circuit	22
Figure 8.	BeagleBone LCD3 Cape EEPROM.....	23
Figure 9.	BeagleBone LCD3 Cape Dimensions Drawing.....	25

Tables

Table 1.	Change History	10
Table 2.	BeagleBone LCD3 Cape Features	13



1.0 Introduction

This document is the System Reference Manual for the BeagleBone LCD3 Cape, an add-on board for the BeagleBone.

This document is intended as a guide to assist anyone purchasing or who are considering purchasing the board to understand the overall design and usage of the BeagleBone LCD3 Cape from the system level perspective.

The design is subject to change without notice as we will work to keep improving the design as the product matures.

The key sections in this document are:

[Section 2.0 – Change History](#)

Provides tracking for the changes made to the System Reference Manual.

[Section 3.0 – Overview](#)

This is a high level overview of the BeagleBone LCD3 Cape.

[Section 4.0 – Features and Specification](#)

Provided here are the features and electrical specifications of the board.

[Section 5.0 – System Architecture and Design](#)

This section provides information on the overall architecture and design of the BeagleBone LCD3 Cape. This is a very detailed section that goes into the design of each circuit on the board.

[Section 6.0 – Mechanical](#)

Information is provided here on the dimensions of the BeagleBone LCD3 Cape.

[Section 7.0 – Design Materials](#)

This section provides information on where to get the design files.

2.0 Change History

2.1 Change History

Table 1 tracks the changes made for each revision of this document.

Table 1. Change History

Rev	Changes	Date	By
A1	Initial release.	06/20/2012	BBT



3.0 BeagleBone LCD3 Cape Overview

3.1 Descriptions

The BeagleBone LCD3 Cape provides a portable LCD solution with touchscreen capability for BeagleBone boards. The 3.5" TFT LCD screen, attached to the topside of the board, can display up to a resolution of 320x240 and is a 4-wire resistive touchscreen. The board is equipped with seven switches located at finger-friendly positions. These switches include power, reset, and five user switches, which are mapped to different GPIO signals. The backside of the Cape is where a BeagleBone can be mounted.

Figure 1 below is a picture of the board.

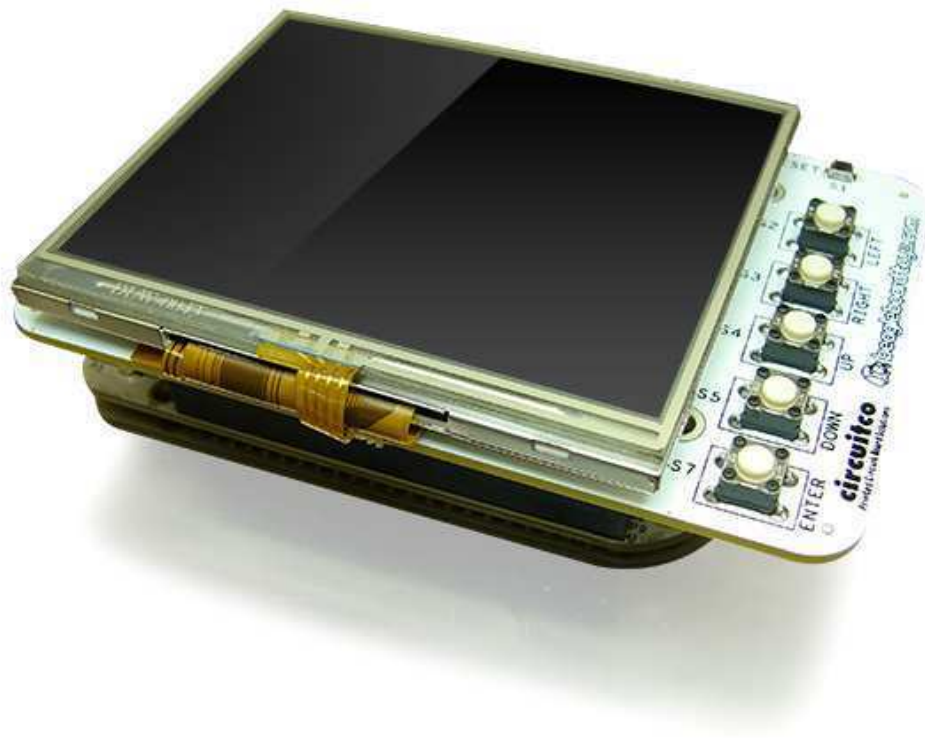

Figure 1. The BeagleBone LCD3 Cape



3.2 In The Box

The final packaged BeagleBone LCD3 Cape Rev A1 product will contain the following items:

- 1 BeagleBone LCD3 Cape with standoffs
- 1 Wiki information card

3.3 Getting Started

Following the instructions below to start using your BeagleBone LCD3 Cape:

1. Mount the BeagleBone to the connectors on the bottom side of the LCD3 Cape.
2. Make sure the SD card using with BeagleBone has Angstrom image 06_18_22 or later.
3. Plug in a 5V DC power supply to the DC connector on the BeagleBone.
4. Following screens will be displayed on the LCD screen:
 - Angstrom log-in prompt
 - Auto Calibration utility (displays only on the first time)
5. Follow the instructions given by the Auto Calibration utility to calibrate the LCD3 touchscreen.
6. After calibrated, the Angstrom desktop will be displayed on the LCD screen.

You can start using the board.

3.4 Repairs

If you feel the board is in need of repair, follow the RMA Request process found at <http://www.beagleboardtoys.com/support/rma>

Do not send the board in for repair until an RMA authorization has been provided.

Do not return the board to the distributor unless you want to get a refund. You must get authorization from the distributor before returning the board.



4.0 Features and Specifications

This section covers the specifications of the BeagleBone LCD3 Cape and provides a high level description of the major components and interfaces that make up the board.

Table 2 provides a list of the BeagleBone LCD3 Cape's features.

Table 2. BeagleBone LCD3 Cape Features

	Feature	
Display	Elpa Displays S035Q01	
LCD Size	3.5"	
Panel Type	a-Si TFT active matrix	
Resolution	320x240	
Colors	16.7M	
Interface	RGB 16-bit	
Touch Panel	Resistive	
Color Depth	RGB 16-bit	
Power Supply	5V DC via BeagleBone expansion	3.3V via BeagleBone expansion
PCB	4.00" x 2.50"	4 layers
Indicators	Power LED	
	User LED	
EEPROM	Board ID EEPROM	
Connectors	46-position male header	
	20-position male header	
	6-position male header	



4.1 Key Component Locations

Figure 3 below shows the top side locations of key components on the PCB layout of the BeagleBone LCD3 Cape:

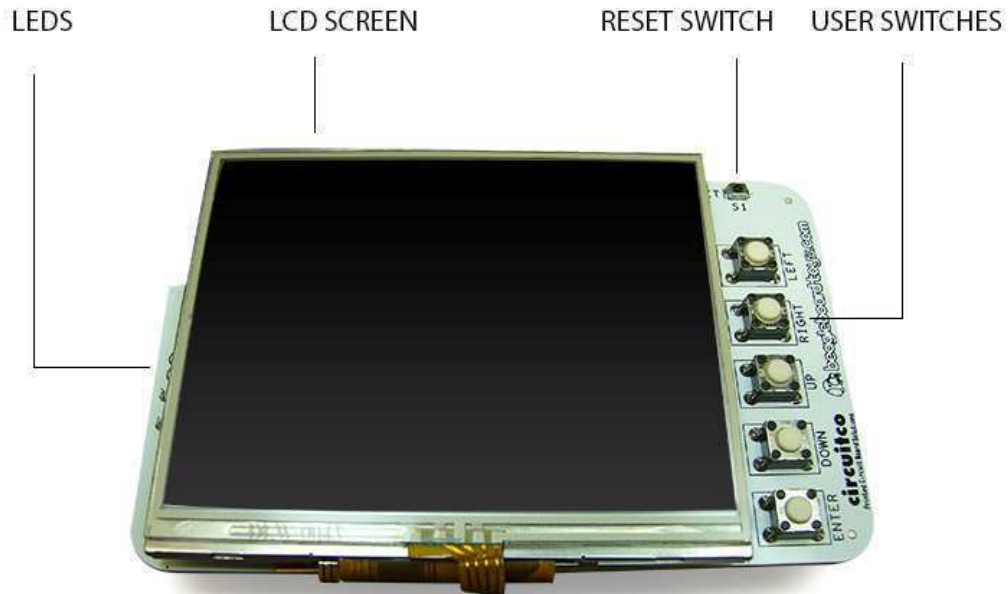

Figure 3. Key Components on top side



Figure 4 below shows key components on the bottom side of the board:

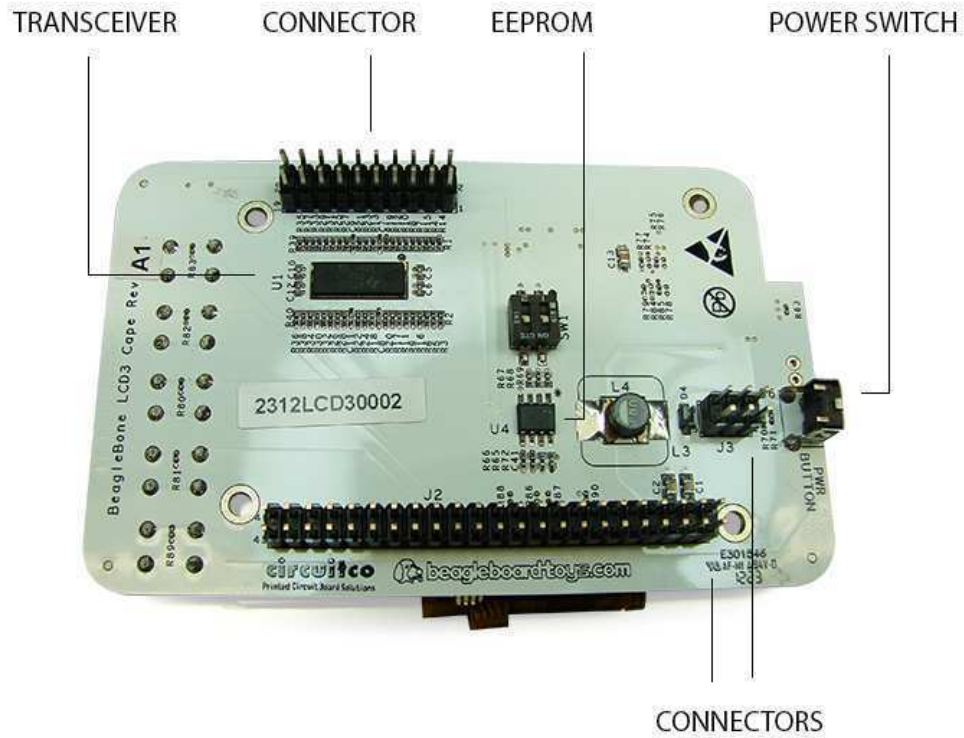

Figure 4. Key Components on bottom side

4.2 LCD Panel

The LCD Panel is supplied by Elpa. The Model number is S035Q01. This display uses amorphous silicon (a-Si) as a switching device. The resolution is 320x240 and it can display up to 16.7M colors.

4.3 Indicators

There is one Power LED and one User LED located on board. Power LED D3 indicates that power is applied to the board. User LED D5 is controlled by GPIO1_18. This signal is exposed as EHRPWM1A at pin 14 on expansion header P9 of BeagleBone. These two LEDs are green when lit and located on top of the Ethernet connector when mounted on a BeagleBone.

4.4 Expansion Header

There are three male connectors located on the bottom side of the board. The 46-position and 20-position connectors will stack on top of the expansion connectors of BeagleBone. The 6-position connector will stack on top of the backlight expansion connector of BeagleBone.

4.5 Switches

The power switch will sit between the Ethernet connector and Power connector when mounted on a BeagleBone. This switch is a through-hole part and is populated at 90 degree to the PCB. The reset switch, on the other hand, is a surface mount part and located on the topside and on the opposite end. The power switch is used to power on or off the board. When the board is powered on, pressing and holding the power switch for 10 seconds will power off the LCD3 Cape. Pressing the power switch again will power on the board. The reset switch is used to reset the board.

Located next to the reset switch on the topside of LCD3 Cape are five user switches. These switches are labeled as Left, Right, Up, Down, and Enter. They are mapped to different GPIO signals, which can be accessed via connector. The reset switch and power switch are connected to the RESET and PWR_BUT signals respectively which can also be accessed at connector J2.

4.6 Mechanical Specifications

Size:	4.00" x 2.50"
Layers:	4
PCB thickness:	.062"
RoHS Compliant:	Yes
Weight:	TBW

4.7 Electrical Specifications

Table 3 is the electrical specification of the external interfaces to the BeagleBone LCD3 panel.

Table 3. BeagleBone LCD3 Electrical Specifications

Specification	Min	Typ	Max	Unit
Power				
Input Voltage DC		3.3		V
Backlight Supply Voltage		5.0		V
Backlight Current Supply		100		mA
Environmental				
Temperature range	0		+85	C



5.0 System Architecture and Design

This section provides a high level description of the design of the BeagleBone LCD3 Cape and its overall architecture.

5.1 System Block Diagram

Figure 7 is the high level block diagram of the BeagleBone LCD3 Cape.

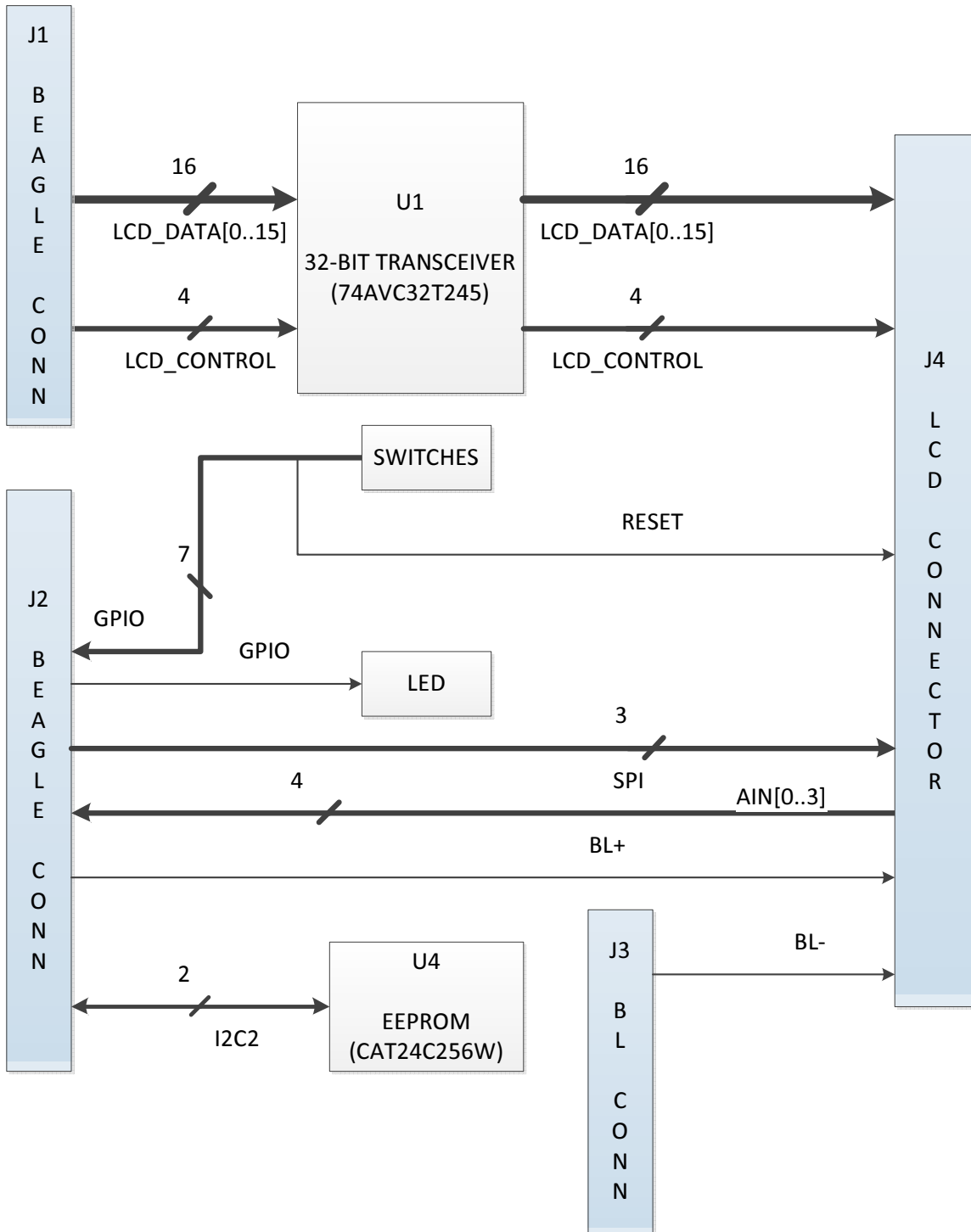

Figure 5. BeagleBone LCD3 Cape High Level Block Diagram



5.2 LCD Interface

5.2.1 Expansion connectors

The LCD interface of the BeagleBone LCD3 Cape uses 16 data and 4 control signals from the BeagleBone's expansion connectors. By using only 16 signals for LCD_DATA, more pins can be available at the expansion header for other capes. The quality of 16-bit LCD output, nonetheless, is very similar to 24-bit. The 4 control signals are horizontal sync (LCD_HSYNC), vertical sync (LCD_VSYNC), enable input (LCD_EN), and the pixel clock (LCD_PCLK). **Figure 5** shows these LCD signals at expansion connector J1.

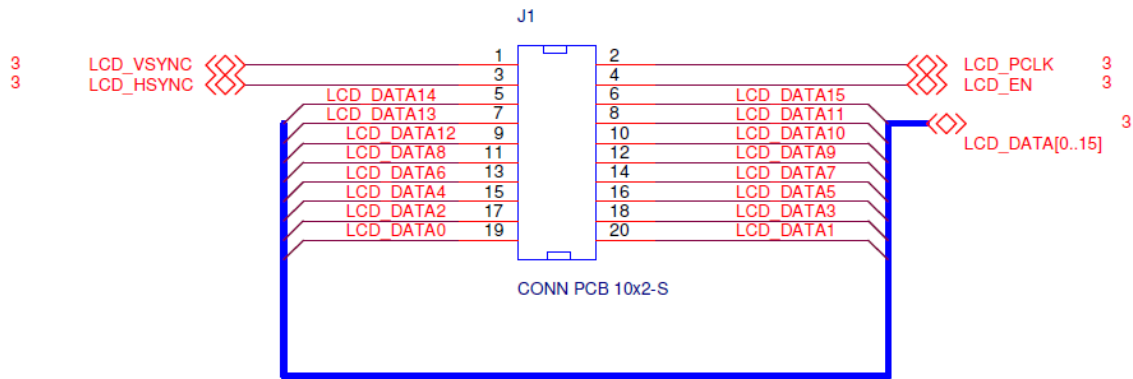

Figure 5. LCD Signals at expansion connector J1

5.2.2 Non-Inverting Bus Transceiver

The LCD signals are buffered through U1 (74AVC32T245), which is a 32-bit dual-supply bus transceiver. 74AVC32T245 features two ports, A and B. Each port tracks a separate power-supply rail. This allows for universal low-voltage translation. The output-enable (OE) input specifies whether the buses are isolated. The direction-control input, on the other hand, determines the data transmission direction. On the BeagleBone LCD3 Cape, no voltage translation required since its two power rails are both 3.3V. Both the direction-control and output-enable inputs are set low, so the data are transmitted from B to A before going to LCD connector J4. **Figure 6** shows the LCD signals are buffered through U1.

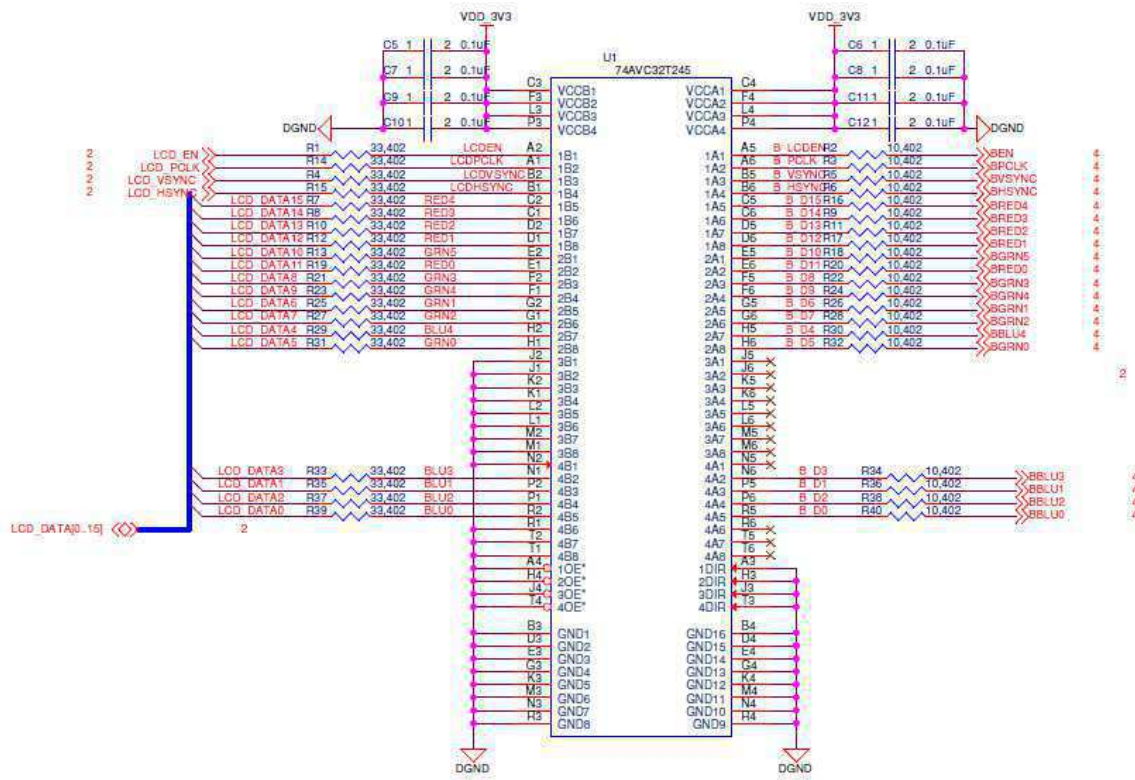

Figure 6. LCD Signals buffered through U1

5.2.3 Touchscreen Interface

The S035Q01 touchscreen is resistive and composed of 4 different X or Y signals. These signals are connected to the analog inputs AIN0 to AIN4, which can be accessed via expansion connector J2. Both touchscreen and LCD flex cables share the same connector J4.



5.3 LCD Power Supply

The Elpa S035Q01 is powered by 3.3V from the expansion connector of BeagleBone. This power is required for logic operation of the LCD module.

The backlight of S035Q01 is composed of 6 LED's that are in series. The forward current for each LED is 20mA and can go up to 25mA. This backlight is driven by BeagleBone's PMIC backlight circuit provided at the backlight expansion connector J3. The backlight circuit is a boost converter and two current sinks capable of driving up to 2x10 LEDs at 25mA or a single string at 50mA of current. The backlight current is set by external resistor R70 and R71. Since the LCD backlight only consists of one LED string, both BL_ISINK pins are shorted together and connected to the Cathode of LED string. The switch pin of the boost converter is connected to SYS_5V power rail via an external inductor, whereas the feedback pin is connected to the Anode of LED string.

Figure 7 shows the backlight circuit of the BeagleBone LCD3 Cape:

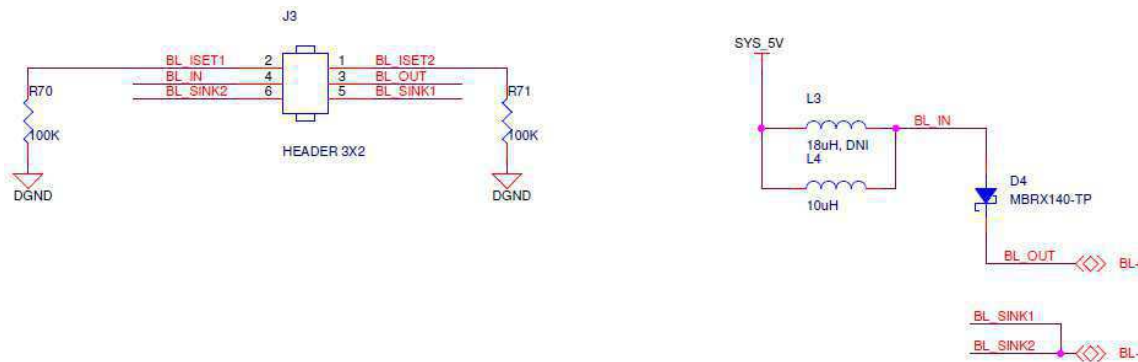

Figure 7. BeagleBone LCD3 Backlight Circuit

5.4 Serial Port Interface

The LCD panel of the BeagleBone LCD3 Cape features NT39016D as the driver IC. This IC uses the 3-wire serial port as communication interface for all function and parameter setting. The serial port interface is not populated in this revision since no parameter changes are necessary for the Elpa S035Q01 panel.

5.5 EEPROM

The BeagleBone LCD3 Cape has an EEPROM containing information that will allow the SW to identify the board and to configure the expansion headers pins as needed. EEPROMs are required for all Capes sold in order for them to operate correctly when plugged in the BeagleBone.

The EEPROM used on this cape is the same one as is used on the BeagleBone, a CAT24C256. The CAT24C256 is a 256 kb Serial CMOS EEPROM, internally organized as 32,768 words of 8 bits each. It features a 64-byte page write buffer and supports the Standard (100 kHz), Fast (400 kHz) and Fast-Plus (1 MHz) I2C protocol. **Figure 8** is the design of the EEPROM circuit.

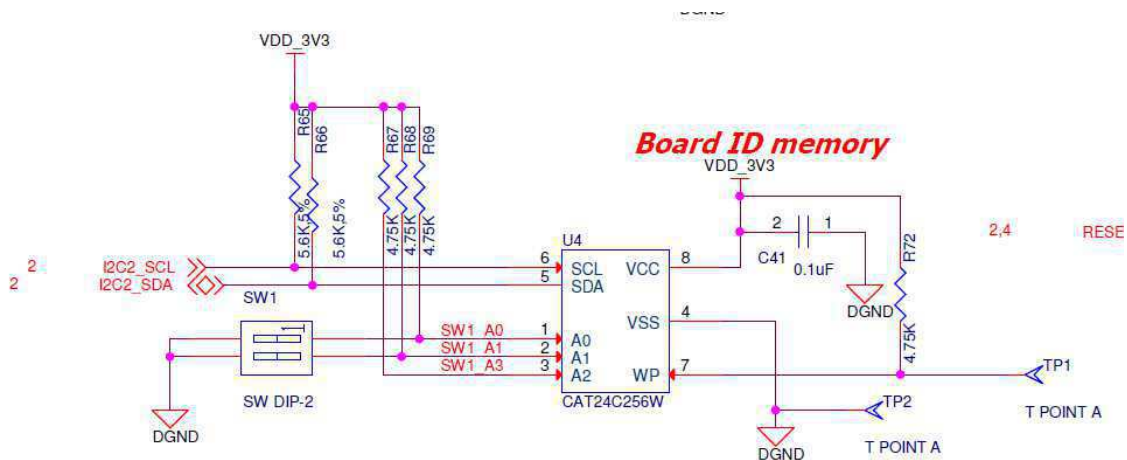

Figure 8. BeagleBone LCD3 Cape EEPROM

5.5.1 EEPROM Address

In order for each Cape to have a unique address, a board ID scheme is used that sets the address to be different depending on the order in which it is stacked onto the main board. A two position dipswitch or jumpers is used to set the address pins of the EEPROM. It is the responsibility of user to set the proper address for each board. Address line A2 is always tied high. This sets the allowable address range for the expansion cards to 0x54 to 0x57. All other I2C addresses can be used by the user in the design of their Capes. But, these addresses must not be used other than for the board EEPROM information.

5.5.2 I2C Bus

The EEPROMs on each expansion board is connected to I2C2. For this reason I2C2 must always be left connected and should not be changed by SW to remove it from the expansion header pin mux. The I2C signals require pull-up resistors. Each board must have a 5.6K resistor on these signals. With four resistors this will be an affective resistance of 1.4K if all Capes were installed.



6.0 Mechanical Information

This section provides information on the mechanical aspect of the BeagleBone LCD3 Cape. **Figure 9** is the dimensions of the BeagleBone LCD3 Cape.

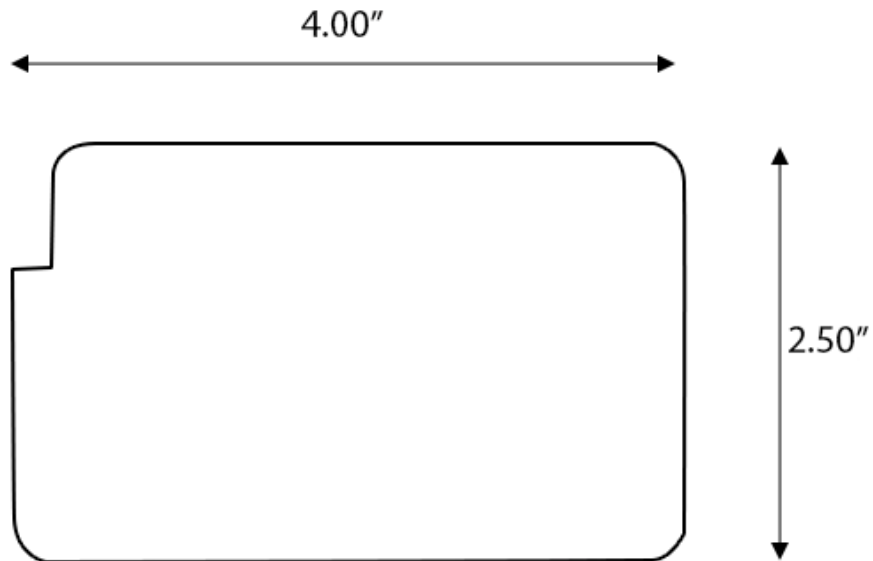

Figure 9. BeagleBone LCD3 Cape Dimensions Drawing



7.0 Design Materials

Design information can be found at BeagleBoardToys wiki:

http://beagleboardtoys.com/wiki/index.php?title=BeagleBone_LCD3

Provided there is:

- Schematic in PDF
- Schematic in OrCAD
- Manufacturing files
 - o PCB Gerber
 - o PCB Layout (Allegro)
- Bill of Materials
- System Reference Manual (This document)

*These design materials are ***NOT SUPPORTED*** and **DO NOT** constitute a reference design. Only “community” support is allowed via resources at BeagleBoard.org/discuss. THERE IS NO WARRANTY FOR THE DESIGN MATERIALS, TO THE EXTENT PERMITTED BY APPLICABLE LAW. EXCEPT WHEN OTHERWISE STATED IN WRITING THE COPYRIGHT HOLDERS AND/OR OTHER PARTIES PROVIDE THE DESIGN MATERIALS “AS IS” WITHOUT WARRANTY OF ANY KIND, EITHER EXPRESSED OR IMPLIED, INCLUDING, BUT NOT LIMITED TO, THE IMPLIED WARRANTIES OF MERCHANTABILITY AND FITNESS FOR A PARTICULAR PURPOSE. THE ENTIRE RISK AS TO THE QUALITY AND PERFORMANCE OF THE DESIGN MATERIALS IS WITH YOU. SHOULD THE DESIGN MATERIALS PROVE DEFECTIVE, YOU ASSUME THE COST OF ALL NECESSARY SERVICING, REPAIR OR CORRECTION.*

We mean it, these design materials may be totally unsuitable for any purposes.