

A new range of CCM03 connectors have been developed to interface with SIM/SAM cards as defined by GSM11-11 and ENV1375-1. The connectors are available with either hinged covers or fixed covers and have been designed to minimize the amount of space needed for PCB mounting.

Features

Hinged Cover

- Available with 6 or 8 contacts, with or without PCB locating pegs.
- Available with insulated card presence switch.
- The cover springs open when unlocked while the card is in place.
- The molding is polarized so that the cover can only be closed if the card is correctly inserted.
- The cover can be replaced without removing the connector from the PCB.
- Inspection slots allow an electrical test to be made without opening the cover.
- The overall height of the connector is only 2,5 mm. The amount of space needed to mount the connector is just 29,65 mm x 17,2 mm.

Fixed Cover

- Available with 6 or 8 contacts.
- The overall height of the connector is 2,85 mm max. Only 25,5 mm x 17,2 mm of board space is required to mount the connector.

General

- With tape and reel packaging as standard, the connectors are designed to be automatically pick-and-placed.
- The high temperature thermoplastic moldings are suited for infrared and convection soldering processes.
- By using an inlay finish in the contact area the life of the precious metal is extended by over 10 times that of standard gold plating.
- Robustly formed printed circuit tails allow a co-planarity of $\pm 0,05$ mm to be maintained.



Construction	
Contacts	Copper alloy
Plating	Contact area : Gold alloy inlay or gold over nickel Terminals : Tin lead (2 μ min)
Moldings	High temp. thermoplastic UL 94V-0 rated
Slide lock/metal cover	Stainless steel
Mechanical Data	
Number of Contacts	6 or 8
Mechanical life, hinged cover	10,000 cycles min
Mechanical life, fixed cover	50,000 cycles
Card insertion force	Hinged cover: 1 N max Fixed cover: 3 N max
Card extraction force	Hinged cover: 1 N max Fixed cover: 0.80 N min / 3 N max
Contact force	0.25 N min / 0.50 N max
Slide locking force	2 N min / 6 N max
Vibration	Frequency 10 to 500 Hz. Acceleration 50m/s ² Duration 6 hours - amplitude 0,35 mm Max electrical discontinuity 1 μ s
Shock	Peak value 500 m/s ² – Duration 11 ms 3 shocks in each direction of each axis Max electrical discontinuity 1 μ s
Contact Electrical Data	
Insulation resistance	1,000 M Ω min
Resistance	100 m Ω max
Current rating	10 μ A min / 1 A max
Dielectric strength	750 Vrms min
Switch Electrical Data	
Card detection switch	Normally open
Contact resistance	100 m Ω max
Dielectric strength	250 Vrms min
Current rating	1 mA min / 10m A max
Maximum power	0.2 VA
Environmental Data	
Operating temperature	-40°C to +85°C
Soldering temperature	Temperature/time profile acc. to CECC00802 para. 6.1, Fig. 3 with peak temperature 250°C
Damp heat	IEC 512 test number 11c (10 days)
Salt mist	IEC 512 test number 11f (96 hours)
Packaging	
Quantity per reel, see table next page.	

Dimensions are shown in mm
Specifications and dimensions subject to change

CCM03 MK II

Ordering Code

Part Number	Number of Contacts	Cover	PCB Locating Pegs	Quantity per reel	Contact Finish	Switch lock	Card Presence switch
CCM03-3001 R102	6	Hinged	No	1000	Inlay	No	No
CCM03-3002 R102	6	Hinged	Yes	1000	Inlay	No	No
CCM03-3003 R102	8	Hinged	No	1000	Inlay	No	No
CCM03-3004 R102	8	Hinged	Yes	1000	Inlay	No <td No	
CCM03-3009 R102	6	Hinged	No	1000	Gold	No	No
CCM03-3010 R102	6	Hinged	Yes	1000	Gold	No	No
CCM03-3011 R102	8	Hinged	No	1000	Gold	No	No
CCM03-3012 R102	8	Hinged	Yes	1000	Gold	No	No
CCM03-3013 R102	6	Hinged	No	1000	Gold	No	Yes (insulated)
CCM03-3514 R102	6	Hinged	No	1000	Inlay	Yes	No
CCM03-3504 R122	8	Fixed	No	1200	Inlay	No	No
CCM03-3505 R122	6	Fixed	No	1200	Inlay	No	No

Dimensional Drawings

Hinged Cover CCM03 - 3001 (6 contacts)

3002 (6 contacts - PCB locating pegs)

3003 (8 contacts)

3004 (8 contacts - PCB locating pegs)

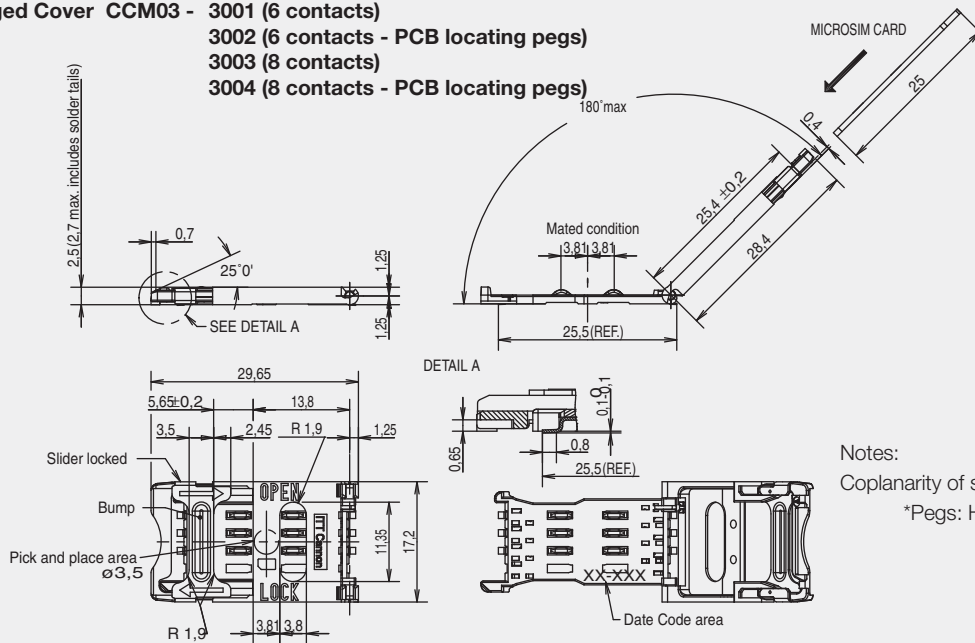

Notes:

Coplanarity of soldering surfaces: $\pm 0,05$ mm

*Pegs: Height 0,7 mm and $\varnothing 1$ mm

PCB Layout

CCM03-3001 / 3002

(Component side)

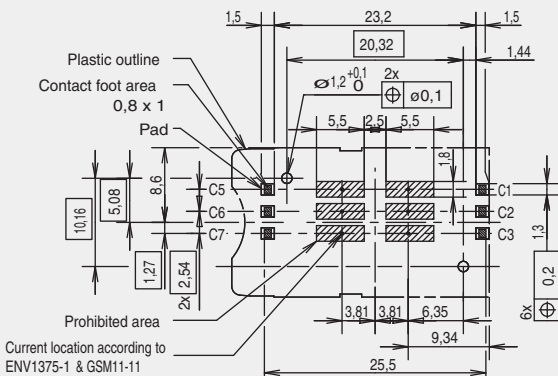

CCM03-3003 / 3004

(Component side)

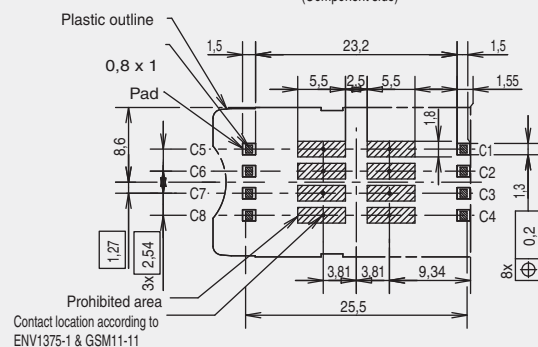

Unless otherwise stated, tolerances are $\pm 0,10$ mm



Dimensions are shown in mm
Specifications and dimensions subject to change

www.ck-components.com

CCM03 MK II Hinged Cover

Insulated Card Presence Switch

Dimensional Drawings

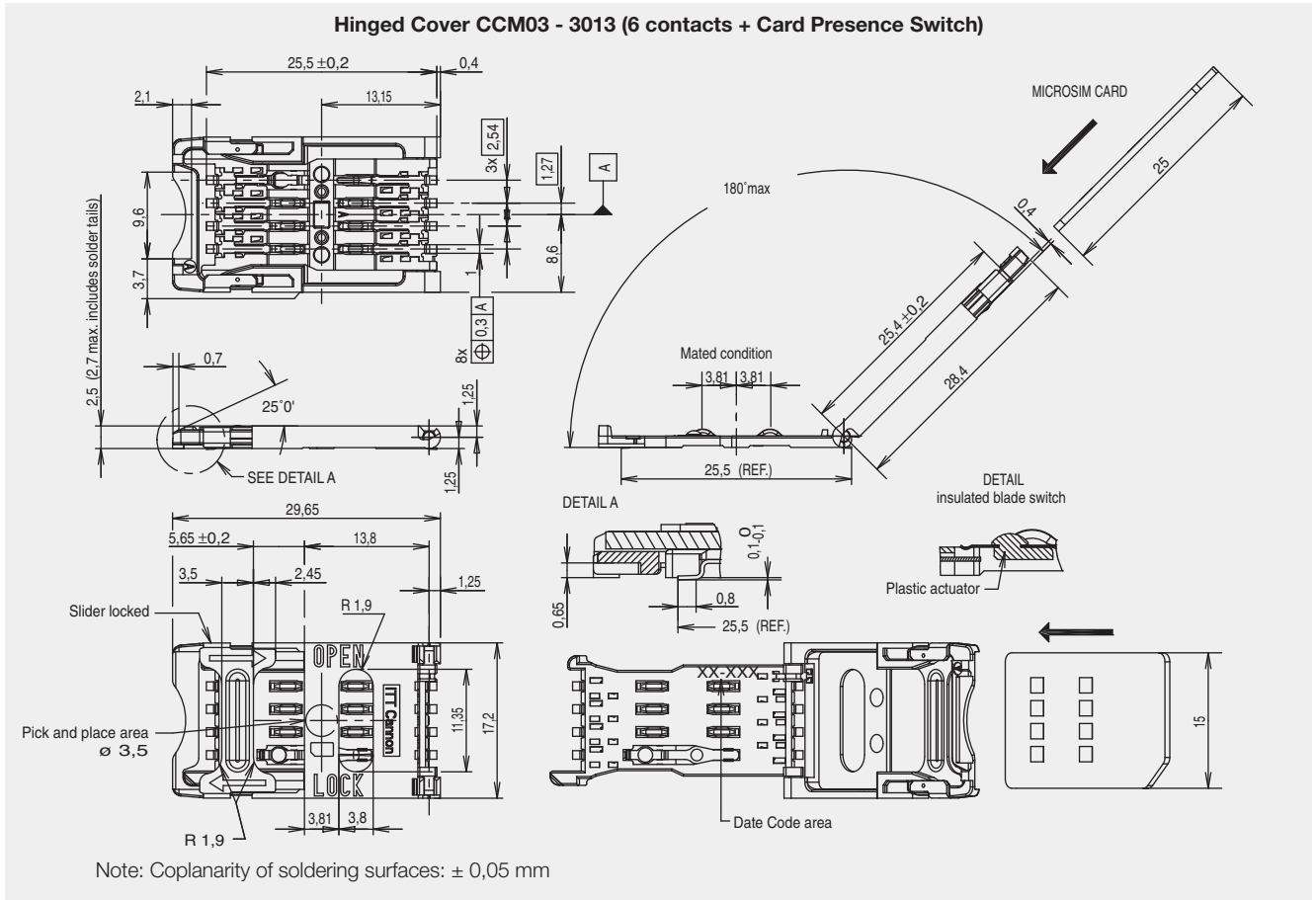

PCB Layout

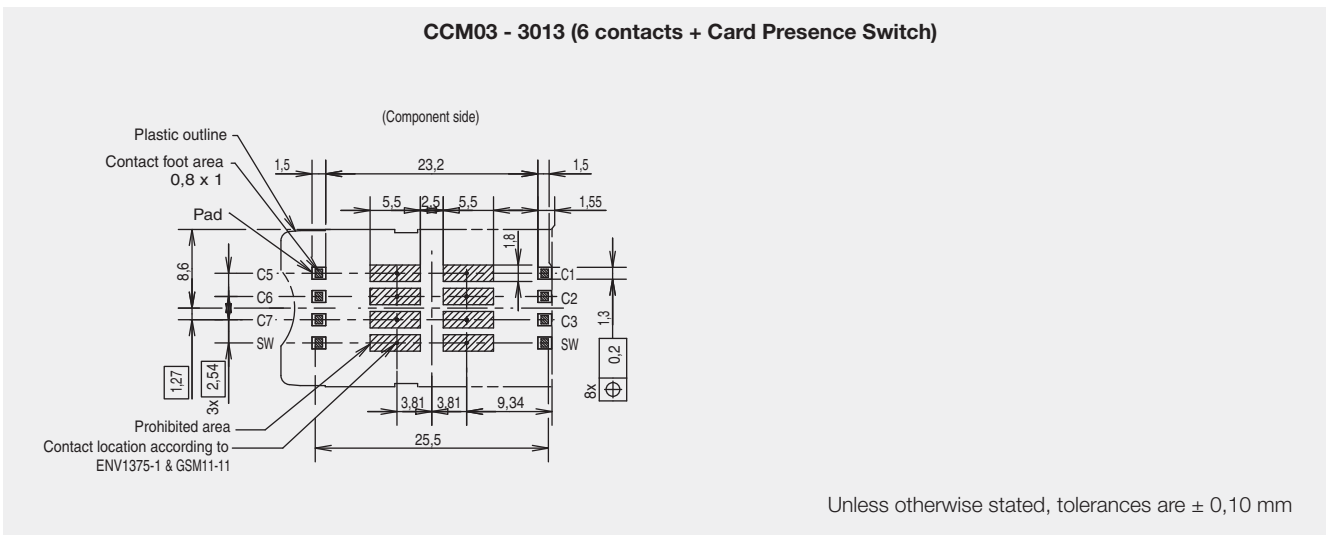

Dimensions are shown in mm
Specifications and dimensions subject to change

www.ck-components.com

CCM03 MK II Hinged Cover

Dimensional Drawings

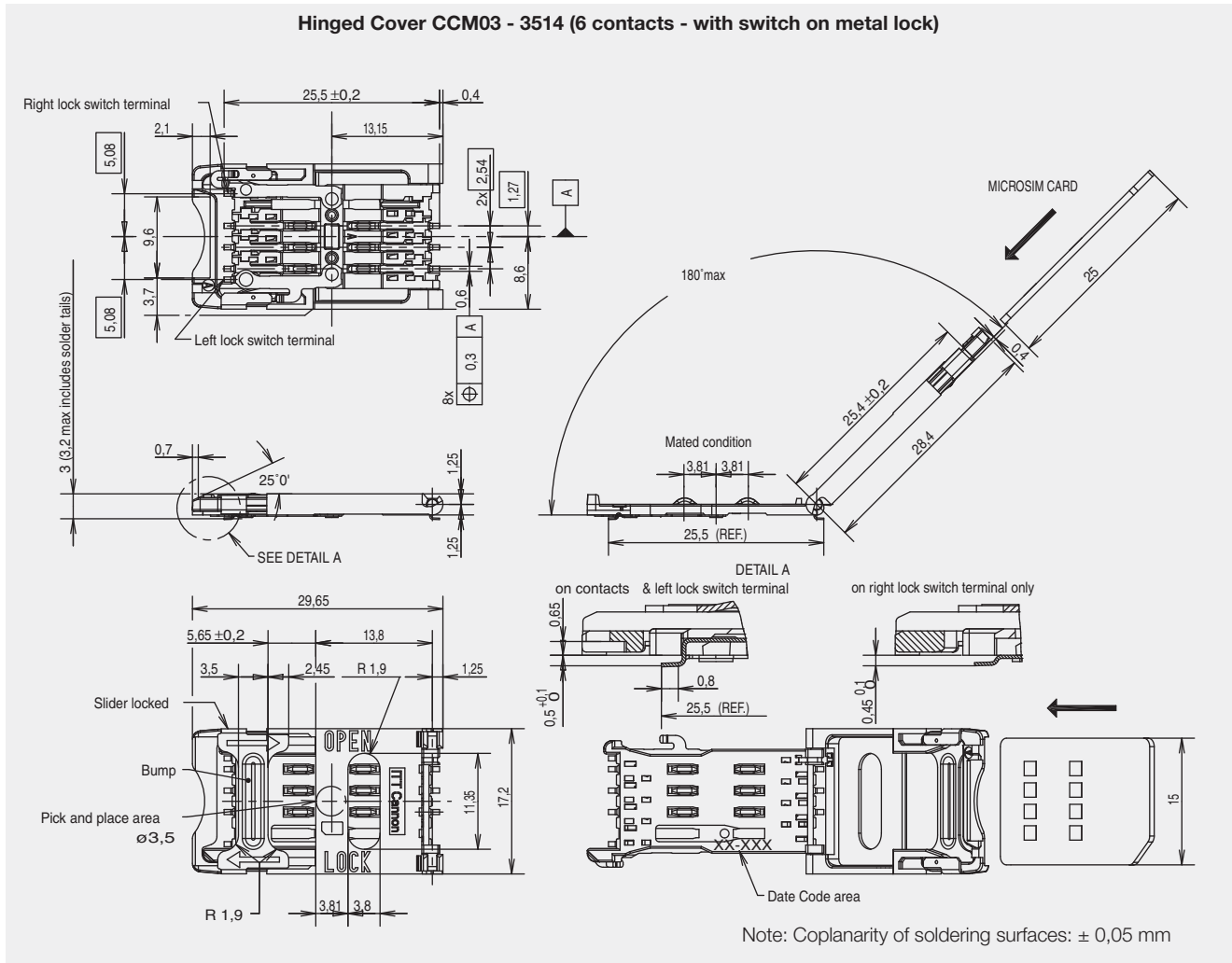

PCB Layout

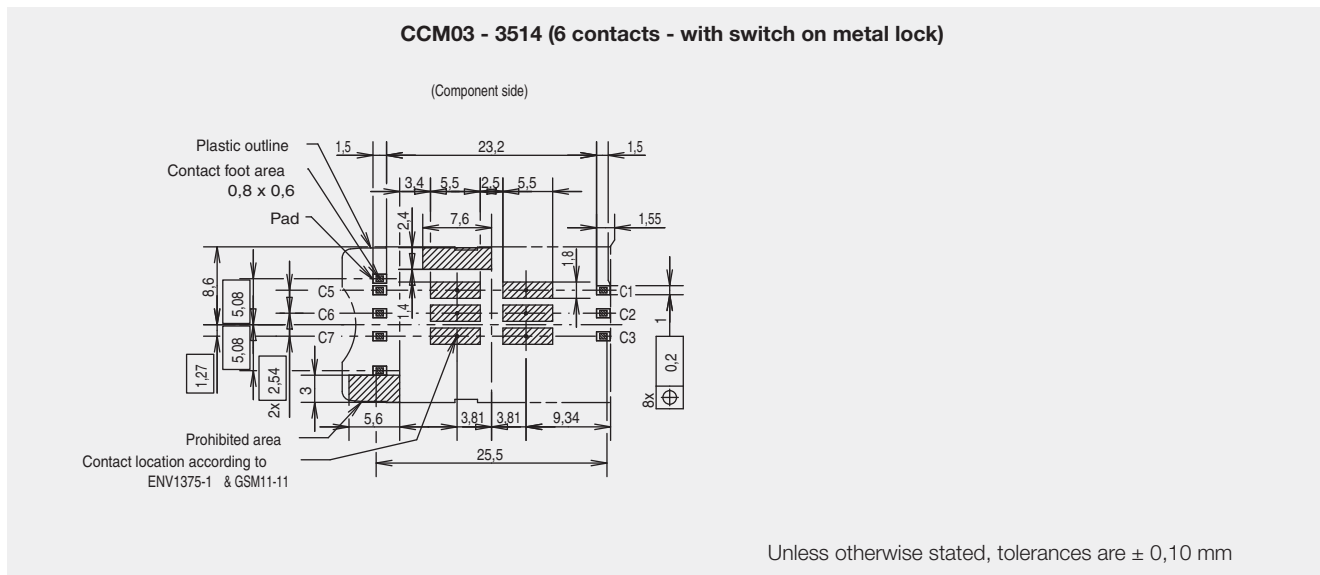

Dimensions are shown in mm
Specifications and dimensions subject to change

www.ck-components.com

CCM03 MK II Fixed Cover

Dimensional Drawings

Fixed cover CCM03 - 3504 (8 contacts)

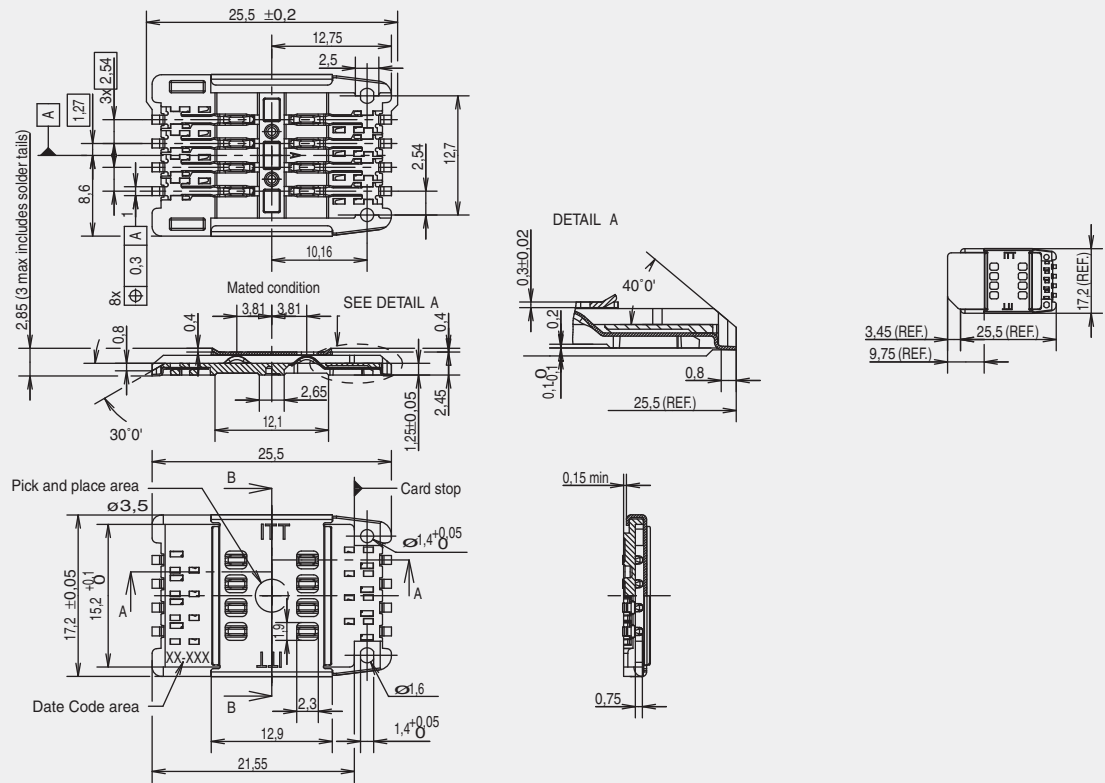

Note: Coplanarity of soldering surfaces: $\pm 0,05$ mm

PCB Layout

CCM03 - 3505

CCM03 - 3504

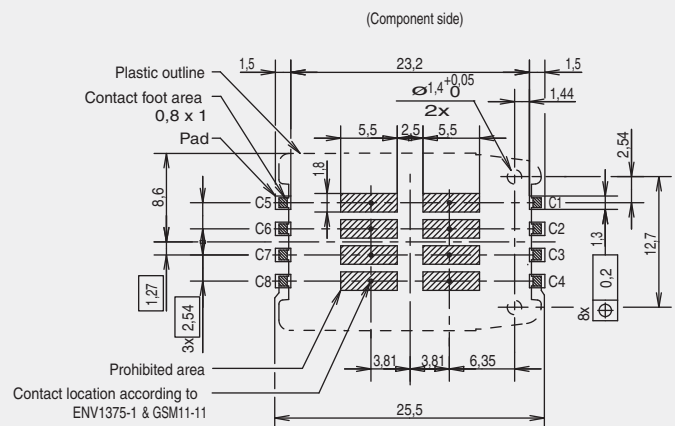
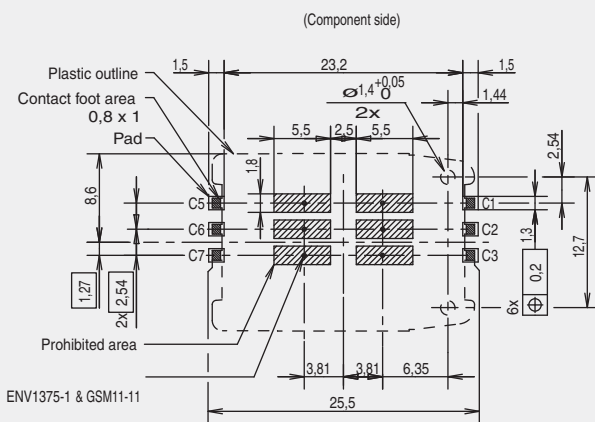

Unless otherwise stated, tolerances are $\pm 0,10$ mm



Dimensions are shown in mm
Specifications and dimensions subject to change

www.ck-components.com