

55 Watt K Triple Series DC/DC Converters

Features

- Very Low Noise, < 50 mV P-P Maximum
- PCB Mounting with Optional Heat Sink or Chassis Mount Versions
- Efficiencies to 87%
- Common and Differential Mode Input Filtering
- Remote Sense On +5 Volt Output
- Single and Dual Outputs are Isolated From Each Other
- No derating to 80°C Case Temperature
- Five Year Warranty

Description

The 55 Watt Triple Series consists of separate power sections for the single and dual outputs. These power sections are operated in anti-phase to each other to reduce the ripple current stress on the input components and the reflected input ripple. The main benefit of two separate power sections is the excellent regulation achieved by all outputs. An order of magnitude regulation improvement is obtained over competitive designs. There is no cross regulation between +5 output and the dual outputs. This means that the dual output voltages are independent of the +5 Volt loading and visa versa.

Excellent noise performance is attained by using a 0.040 inch thick aluminum case, pot core and toroidal magnetics, double shielded transformers and both normal mode and common mode input filtering.

The input and outputs are protected from overvoltage by transient voltage suppressor diodes. The outputs are protected from faults with pulse by pulse digital current limiting.

Selection Chart				
Model	Input Range VDC		Outputs VDC	Outputs mA
	Min	Max		
12T5.12K	9.0	18.0	5, ±12	5000, ±1250
12T5.15K	9.0	18.0	5, ±15	5000, ±1000
24T5.12K	18.0	36.0	5, ±12	5000, ±1250
24T5.15K	18.0	36.0	5, ±15	5000, ±1000
48T5.12K	36.0	72.0	5, ±12	5000, ±1250
48T5.15K	36.0	72.0	5, ±15	5000, ±1000

55 Watt Triple Series Block Diagram

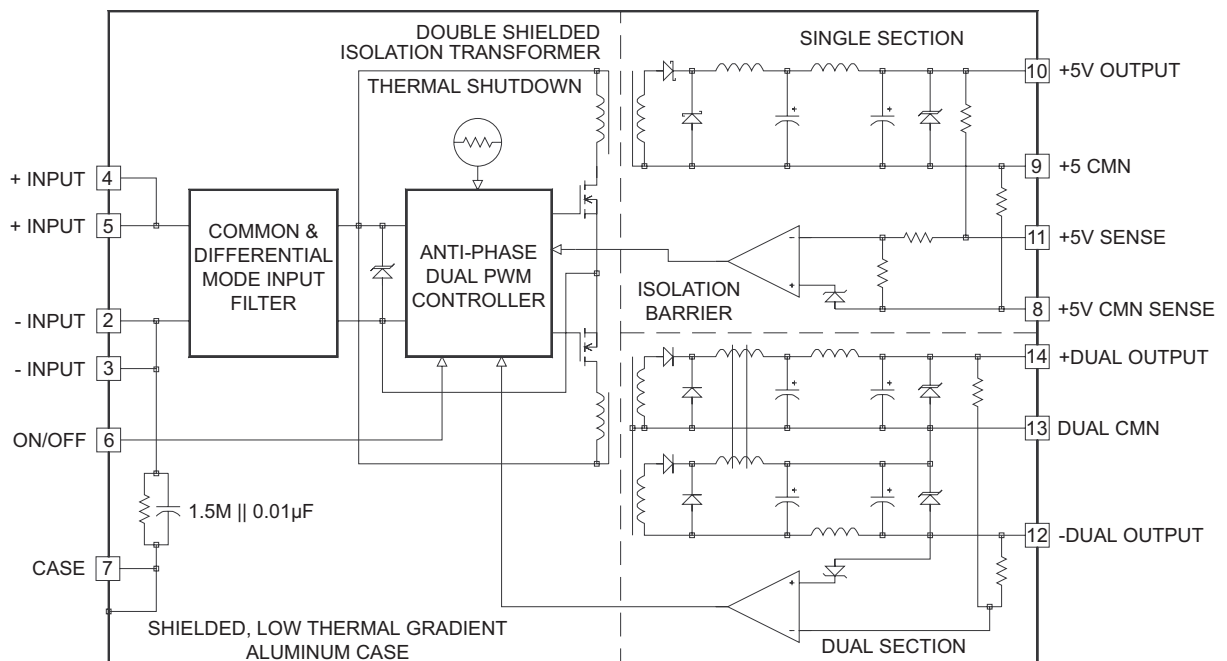

55 Watt K Triple Series DC/DC Converters

Input Parameters*								
Model		12T5.12K	12T5.15K	24T5.12K	24T5.15K	38T5.12K	48T5.15K	Units
Voltage Range	MIN	9.0		18.0		36.0		VDC
	MAX	18.0		36.0		72.0		
Reflected Ripple (2), 0-20MHz bw	TYP	110		60		35		mA P-P
	MAX	250		150		80		
Input Current Full Load	TYP	5630		2715		1325		mA
	No Load	50		35		30		
Efficiency	TYP	81		85		87		%
Switching Frequency	TYP	80						kHz
Maximum Input Overvoltage, 100ms No Damage	MAX	23		45		85		VDC
Turn-on Time, 1% Output Error	TYP	70						ms
Recommended Fuse		(3)						AMPS

Output Parameters*								
Model		12T5.12K 24T5.12K 48T5.12K	12T5.15K 24T5.15K 48T5.15K	12T5.12K 24T5.12K 48T5.12K	12T5.15K 24T5.15K 48T5.15K	12T5.15K 24T5.15K 48T5.15K	Units	
Output Voltage		+5		±12		±15		VDC
Rated Current (4)	MIN	50		310		250		mA
	MAX	5000		1250		1000		
Voltage Range 100% Load (5)	MIN	4.950		11.925		14.925		VDC
	TYP	5.000		12.000		15.000		
	MAX	5.050		12.075		15.075		
Output Balance (Plus to Minus Output, Full Load)	TYP	N/A		0.5		0.5		%
	MAX	N/A		0.7		0.7		
Load Regulation 25%-100% 1-100%	TYP	0.02		0.8		0.7		%
	MAX	0.2		1.2		1.2		
	TYP	0.02		2.0		2.0		
	MAX	0.2		4.0		4.0		
Cross Regulation (6)	TYP	N/A		0.8		0.7		%
	MAX	N/A		1.2		1.2		
Line Regulation Vin = Min-Max VDC	TYP	0.02						%
	MAX	0.2						
Short Term Stability (7)	TYP	0.02						%
Long Term Stability	TYP	0.2						%/kHrs
Transient Response (8)	TYP	500		400		400		µs
Dynamic Response (9)	TYP	250		250		200		mV peak
Input Ripple Rejection (10)	TYP	25		15		15		dB
Noise, 0-20MHz bw	TYP	15						mV P-P
	MAX	50						
Temperature Coefficient	TYP	50		50		50		ppm/°C
	MAX	100		200		200		
Overvoltage Clamp (11)	TYP	6.8		15		18		VDC
Short Circuit Protection to Common for all Outputs		Provides minimum of 8 hours continuous protection with current limiting and thermal overload techniques						

NOTES

- * **All parameters measured at Tc = 25 °C, nominal input voltage and full rated load unless otherwise noted. Refer to the CALEX Application Notes for the definition of terms, measurement circuits and other information.**
- Noise is measured per CALEX Application Notes. Measurement bandwidth is 0 - 20 MHz.
 - Determine the correct fuse size by calculating the maximum DC current drain at low line input, maximum load and then adding 20 to 25% to get the desired fuse size. A slow blow type fuse is recommended. For reverse voltage protection on the input this fuse must be used.
 - Minimum load is required for rated regulation only, no module damage will occur if the output is run at less than minimum load. Maximum output power on the dual section is 30 Watts (i.e. one output can draw 30 Watts and the other 0 Watts). Regulation degrades with substantial loading unbalance.
 - The remote sense pins must be connected to their respective output pins for proper output voltage and regulation. The combined drop on each output line to its respective remote sense pin must be less than 0.3 volts or 0.6 volts for both sense lines combined.
 - Cross regulation is defined as the change in one output when the other output is changed from minimum to maximum load.
 - Short term stability is specified after a 30 minute warm-up at full load, constant line, load and ambient conditions.
 - Transient response is defined as the time for the output to settle from a 50 to 75% step load change to a 2% error band (rise time of step = 2µ Sec).
 - Dynamic response is defined as the peak overshoot during a transient as defined in note 8 above.
 - The input ripple rejection is specified for DC to 120 Hz ripple with a modulation amplitude of 1% of Vin.

55 Watt K Triple Series DC/DC Converters

General Specifications*			
All Models			Units
ON/OFF Function (12)			
ON Logic Level or Leave Pin Open	MIN	4.5	VDC
OFF Logic Level	MAX	1.2	VDC
Input Resistance	TYP	2	k ohms
Converter Idle Current, ON/OFF Pin Low	TYP	25	mA
Isolation			
Isolation Voltage			
Input to Either Output	MIN	1544	VDC
Single to Dual Output	MIN	700	
Input-Case	MIN	250	
Either Output to Case 10µA Leakage	MIN	1544	
Input to Output Capacitance			
Input to Single Output	TYP	100	pF
Input to Dual Output	TYP	150	
Single to Dual Output	TYP	75	
Environmental			
Case Operating Range	MIN	-25	°C
No Derating	MAX	80	
Case Functional Range (13)	MIN	-40	°C
	MAX	90	
Storage Range	MIN	-40	°C
	MAX	100	
Thermal Impedance (14)			°C/Watt
Pin Mount Version	TYP	2.7	
Option -HS (Heat Sink)	TYP	1.8	
Option -CM (Chassis Mount)		(14)	
Thermal Shutdown Case Temperature	TYP	90	°C
General			
Unit Weight		14	oz.
Mounting Kits		See Case Options	

- (11) For module protection only, see also note 3.
- (12) The ON/OFF pin is Open Collector TTL, CMOS, and relay compatible. The input to this pin is referenced to -Input (pin 2).
- (13) The functional temperature range is intended to give an additional data point for use in evaluating this power supply. At the low functional temperature the power supply will function with no side effects, however, sustained operation at the high functional temperature will reduce expected operational life. The data sheet specifications are not guaranteed over the functional temperature range.
- (14) The case thermal impedance is specified as the case temperature rise over ambient per package watt dissipated. The thermal resistance of the Chassis Mount version depends on the mounting surface. If the mounting surface is a poor thermal conductor the thermal resistance can be as high as 2.7° C/watt. If the mounting surface is an excellent thermal conductor the thermal resistance can be below 1°C/watt.
- (15) Water Washability - Calex DC/DC converters are designed to withstand most solder/wash processes. Careful attention should be used when assessing the applicability in your specific manufacturing process. Converters are not hermetically sealed.

Mounting Configuration Options

To order the optional heat sink on the pin mount version place a "-HS" suffix on the part number. To order the chassis mount version place a "-CM" suffix on the part number. The heat sink and chassis mount options cannot be used together.

Heat Sink Option (-HS suffix)

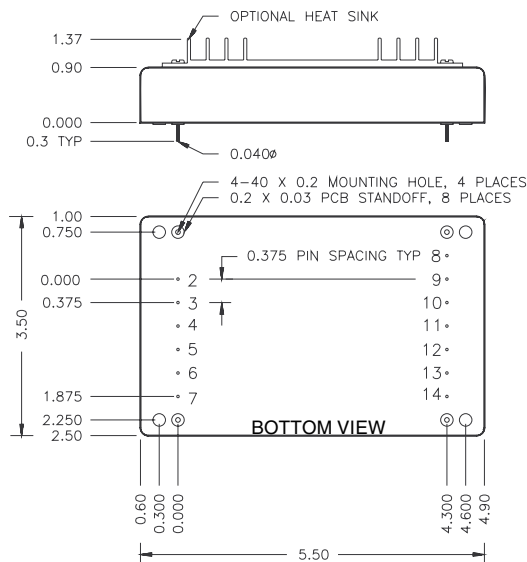

Chassis Mount Option (-CM suffix)

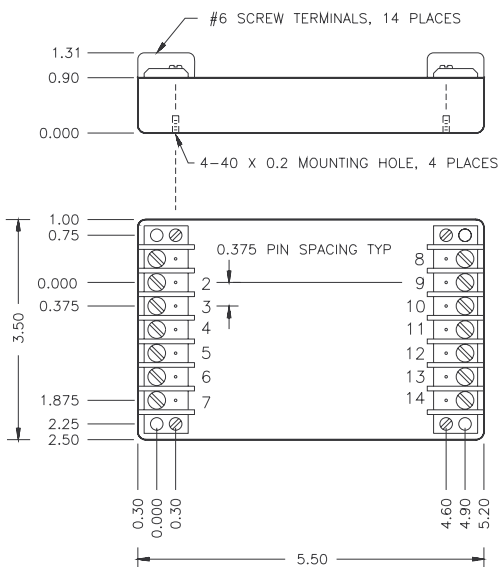

Mechanical tolerances unless otherwise noted:

X.XX dimensions: ±0.020 inches

X.XXX dimensions: ±0.005 inches

Seal around terminals is not hermetic. Do not immerse units in any liquid.

Pin	Function	Pin	Function
1	NO PIN	8	+5V CMN SENSE
2	-INPUT	9	+5V CMN
3	-INPUT	10	+5V OUTPUT
4	+INPUT	11	+5V SENSE
5	+INPUT	12	-DUAL OUTPUT
6	ON/OFF	13	DUAL CMN
7	CASE	14	+DUAL OUTPUT

55 Watt K Triple Series DC/DC Converters

Application Guidelines

Inputs

The input should be fused as per note number 3. The case is connected to the -INPUT pins through 1.5 Megohms in parallel with 0.01 μ F. The case may be left floating in most applications. The noise performance of the converter may improve or degrade with the case connected to other inputs or outputs depending on your system grounding.

The remote ON/OFF pin may be left floating if it is not used. See “Understanding the Remote ON/OFF Function” application note for more information on this feature.

The dual input pins (2,3 and 4,5) should be paralleled to share the input current. Figure 1 shows the recommended input connections.

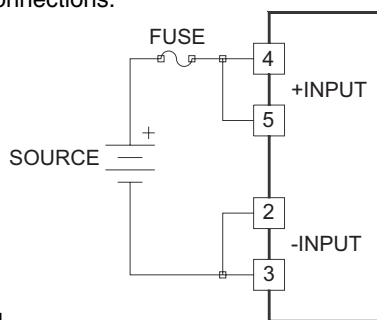

Figure 1.

Parallel both + and -INPUT pins. Fusing the input is recommended.

Single Output

The single output is independent of the loading on the dual output section. The single output also features provisions for remote sense connections. These allow the power supply to correct for line drops of up to 0.3 volts per leg or 0.6 volts total. The remote sense connections should be made with twisted pair wire or closely coupled PCB traces. There is approximately 2mA of current flowing in the remote sense lines. If the remote sense is not to be used, these pins must be connected to their respective output pins for proper output voltage accuracy and regulation. See “Applying the Remote Sense and Trim Functions On DC/DC Converters” application note for more information. The output common on the single section is electrically isolated from the dual section to aid in proper system grounding. Figure 2 shows the single output connections with remote sense.

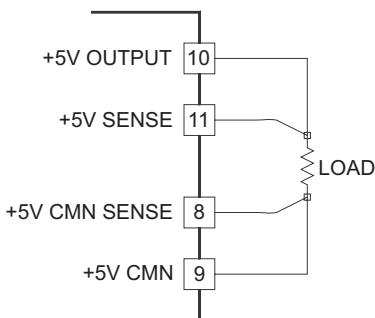

Figure 2.

The remote sense pins must be connected to their respective outputs. If the remote sense feature is not used, connect the sense pins to their outputs directly at the converter.

Dual Output

The dual outputs are cross regulated to each other but independent of the loading on the single output. The dual output uses a cross regulation scheme where the plus and minus output voltage is regulated as an average voltage. This allows improved regulation on both outputs. If the outputs are loaded equally and the regulation is checked, then the apparent regulation is much closer to 0.5%. This data shows the worst case result of changing each output independently. The output common on the dual section is electrically isolated from the +5 volt section to aid in proper system grounding. If 24 volts or 30 volts are required, then the appropriate output can be connected to the system ground and the output current can be taken from the other output. In this situation the dual section's common pin (Pin 13) should be left unconnected. Full output power (30 watts) is available in this configuration. Figure 3 shows the dual output connections.

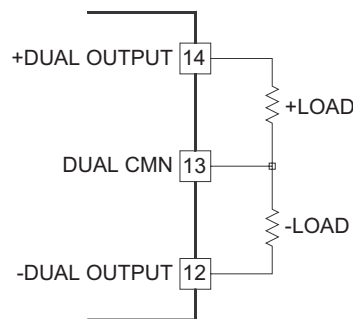

Figure 3.

The dual outputs can also be used with substantial unbalance and as single-ended outputs by leaving Pin 13 unconnected.

Mounting Guidelines

The 55 Watt Triple Series can be supplied in either a pin mount version or a chassis mount (screw terminal) version. It is suggested that when using the pin mount version, the 4-40 hold down screws provided in the bottom of the case be used to secure the unit to the PCB. These screws should be tightened before soldering to avoid solder joint stress.

The chassis mount version can be mounted on its back with the four 4-40 hold down screws provided. The mounting surface should be flat to within 0.01 inches to prevent warping the case. The mounting can then serve as additional heat sinking. For optimum heat sinking, silicone grease is recommended over the so called “dry pads.” Additional heat sinking will lower internal temperatures and increase the expected life. When chassis mounting remember that the case is connected to the - INPUT pins through 1.5 Megohms in parallel with 0.01 μ F. The breakthrough voltage of this connection is greater than 250VDC.

The “-HS” heat sink option lowers the thermal resistance from 2.7 to 1.8 $^{\circ}$ C/Watt dissipated. It also increases the heat removing efficiency of any cooling air flow. If the 55 Watt Triple is to be placed in a small enclosure where the power delivered to the load or the power dissipated in the 55 Watt Triple converter can raise the ambient temperature then care must be taken to insure that the case temperature does not exceed the 80 $^{\circ}$ C limit for proper operation.

55 Watt K Triple Series DC/DC Converters

Typical Performance (Tc=25°C, Vin=48 VDC, Rated Load).

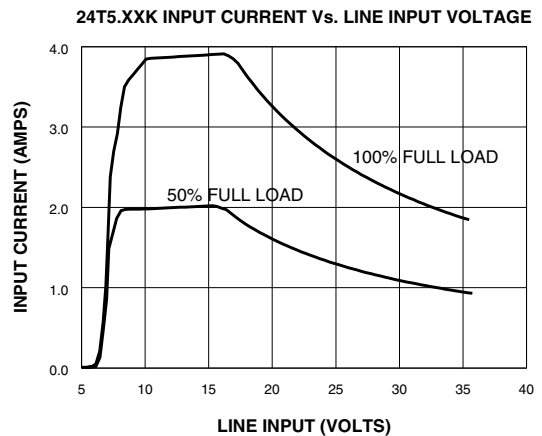
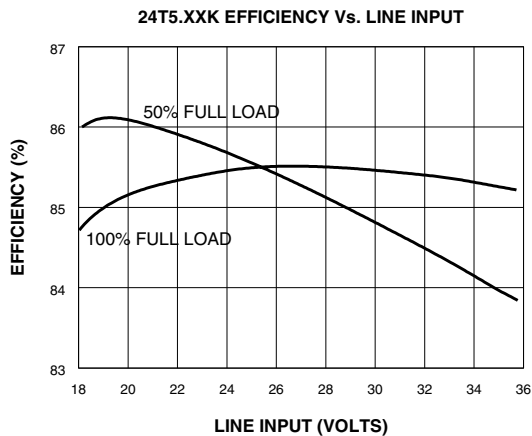
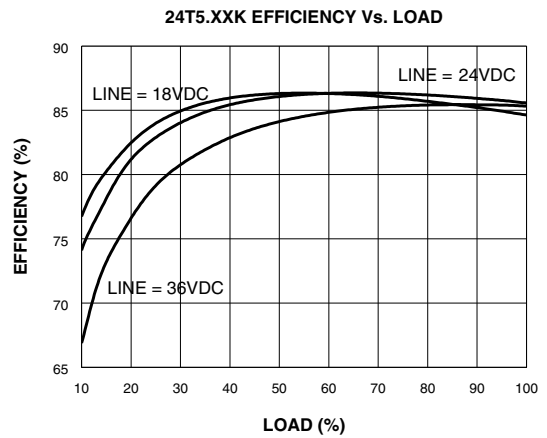
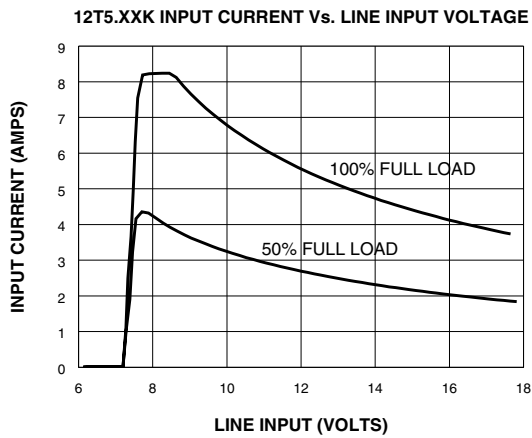
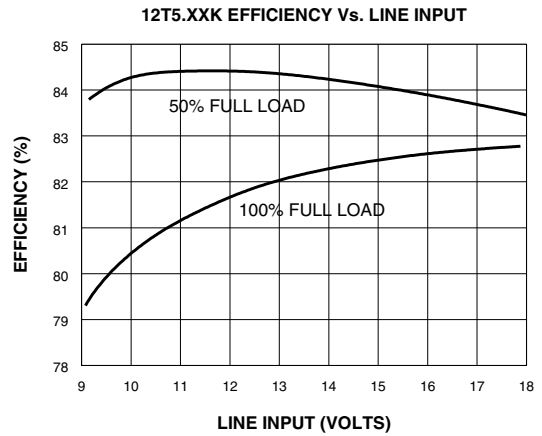
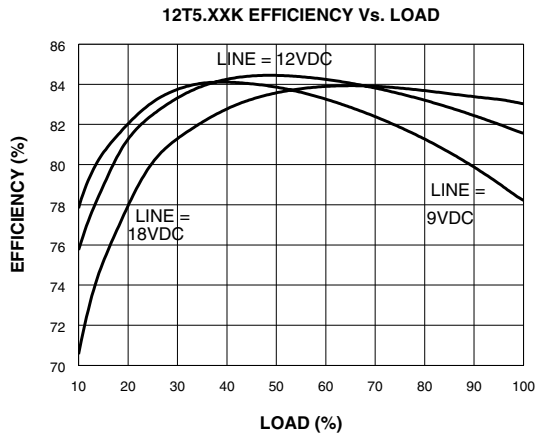

55 Watt K Triple Series DC/DC Converters

Typical Performance (Tc=25°C, Vin=48 VDC, Rated Load).

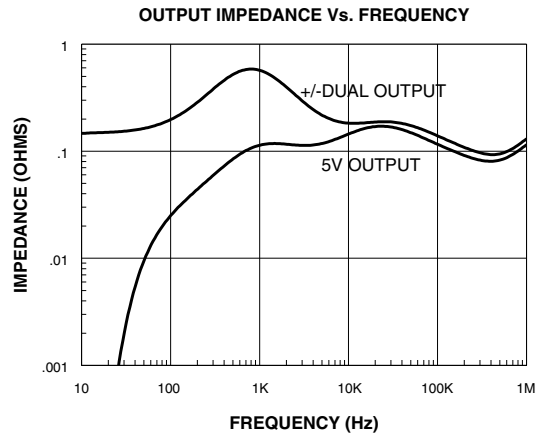
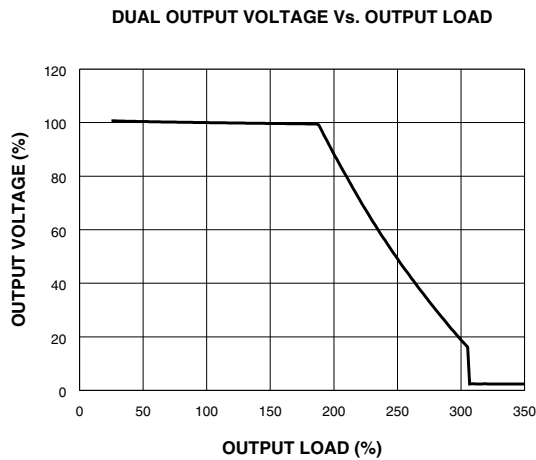
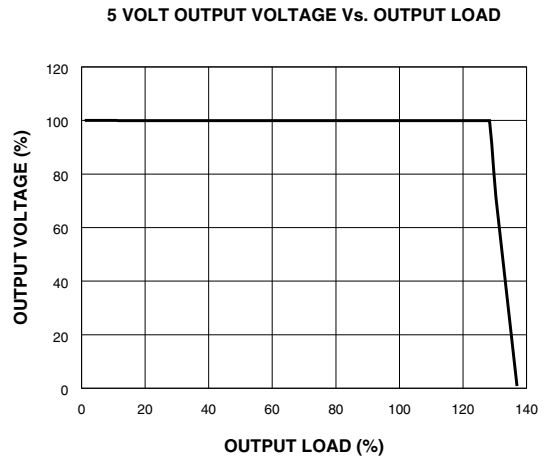
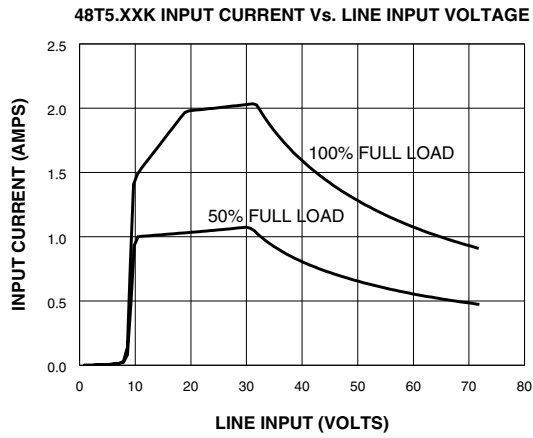
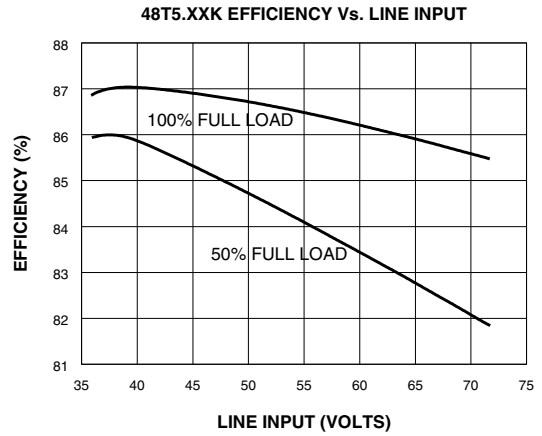
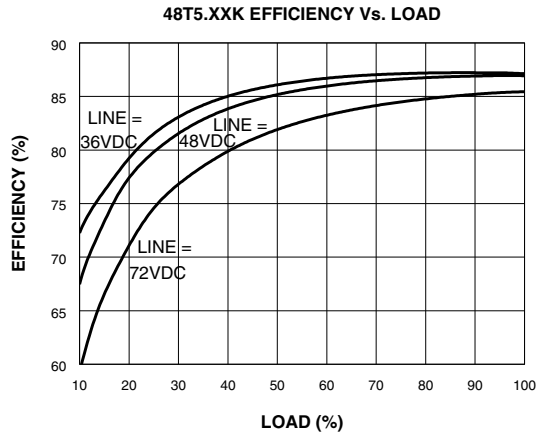

55 Watt K Triple Series DC/DC Converters

Typical Performance ($T_c=25^\circ\text{C}$, $V_{in}=48\text{ VDC}$, Rated Load).

