

Analog Peripherals

10-Bit ADC

- ± 1 LSB INL; guaranteed monotonic
- Programmable throughput up to 100 ksp/s
- 13 external inputs; programmable as single-ended or differential
- Programmable amplifier gain: 16, 8, 4, 2, 1, 0.5
- Data-dependent windowed interrupt generator
- Built-in temperature sensor (± 3 °C)

High-Voltage Differential Amplifier

- 60 V common mode input range
- Offset adjust from -60 to +60 V
- 16 gain settings from 0.05 to 16

Three Comparators

Internal Voltage Reference

Precision V_{DD} Monitor/Brown-out Detector

On-Chip JTAG Debug & Boundary Scan

- On-chip debug circuitry facilitates full speed, non-intrusive in-system debug (no emulator required)
- Provides breakpoints, single stepping, watchpoints, stack monitor, program trace memory
- Inspect/modify memory and registers
- Superior performance to emulation systems using ICE-chips, target pods, and sockets
- IEEE1149.1 compliant boundary scan

Supply Voltage: 2.7 to 3.6 V

- Typical operating current: 10 mA at 25 MHz
- Multiple power saving sleep and shutdown modes

Temperature Range: -40 to +85 °C

High-Speed 8051 μ C Core

- Pipelined instruction architecture; executes 70% of instructions in 1 or 2 system clocks
- Up to 25 MIPS throughput with 25 MHz system clock
- Expanded interrupt handler

Memory

- 4352 bytes data RAM
- 64 kB Flash; in-system programmable in 512-byte sectors (512 bytes are reserved)
- External parallel data memory interface

CAN Bus 2.0B

- 32 message objects
- "Mailbox" implementation only interrupts CPU when needed

Digital Peripherals

- 64 port I/O; all are 5 V tolerant
- Hardware SMBus™ (I2C™ compatible), SPI™, and two UART serial ports available concurrently
- Programmable 16-bit counter array with 6 capture/compare modules
- 5 general-purpose 16-bit counter/timers
- Dedicated watchdog timer; bidirectional reset
- Real-time clock mode using timer 3 or PCA

Clock Sources

- Internal programmable 2% oscillator: up to 25 MHz
- External oscillator: Crystal, RC, C, or Clock

Package

- 100-pin TQFP (standard lead and lead-free packages)

Ordering Part Numbers

- Lead-free package: C8051F044-GQ
- Standard package: C8051F044

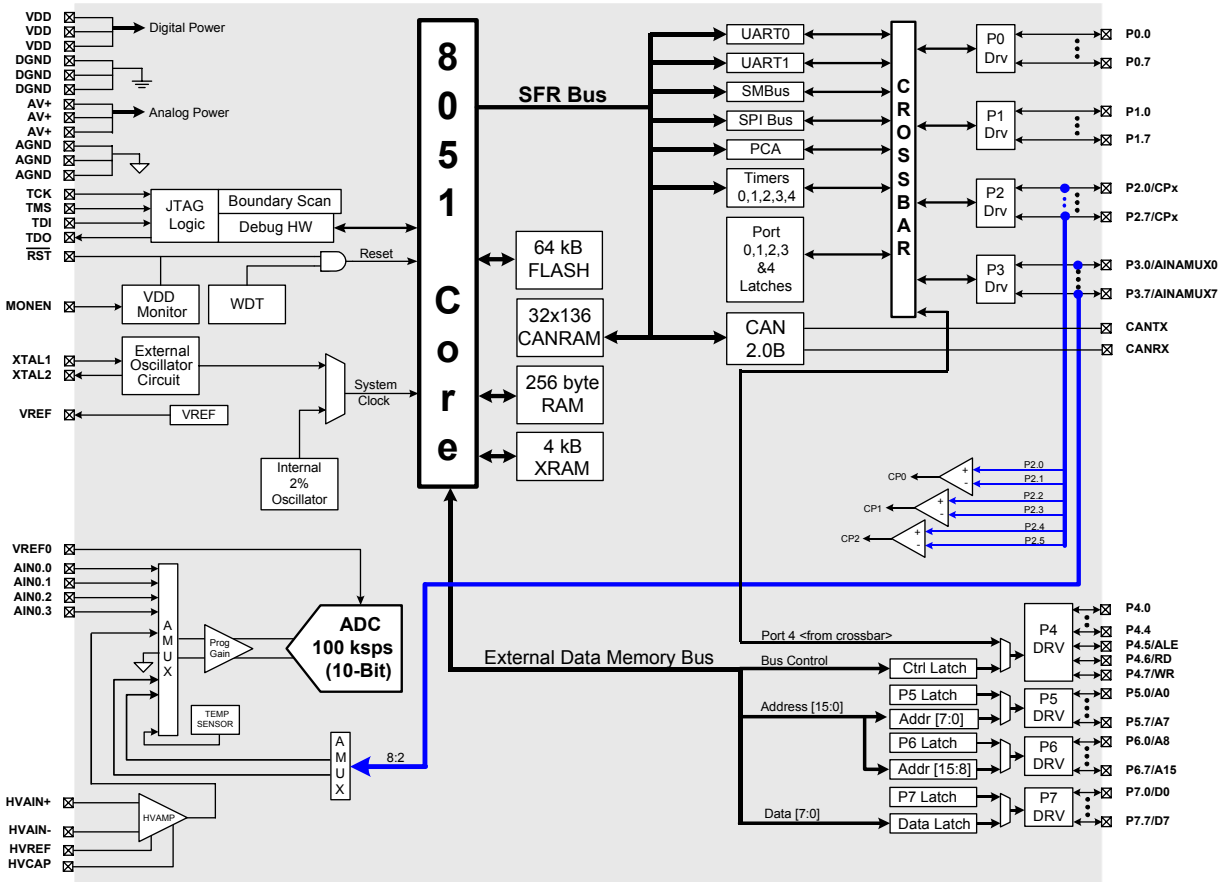

Selected Electrical Specifications

($T_A = -40$ to $+85$ C°, $V_{DD} = 2.7$ V unless otherwise specified)

Parameter	Conditions	Min	Typ	Max	Units
Global Characteristics					
Supply Voltage		2.7	—	3.6	V
Supply Current with CPU active	Clock = 25 MHz	—	10	—	mA
	Clock = 1 MHz		0.5		mA
	Clock = 32 kHz; V_{DD} Monitor Enabled		20		μ A
Supply Current (shutdown)	Oscillator off; V_{DD} Monitor Disabled	—	0.1	—	μ A
Clock Frequency Range		DC	—	25	MHz
A/D Converter					
Resolution		—	10	—	bits
Integral Nonlinearity		—	—	± 1	LSB
Differential Nonlinearity	Guaranteed Monotonic			± 1	LSB
Signal-to-Noise Plus Distortion		59	—	—	dB
Throughput Rate		—	—	100	ksp/s
Input Voltage Range		0	—	V_{REF}	V
Comparators					
Supply Current	(each Comparator)	—	1.5	—	μ A
Response Time	($CP+ - CP-$) = 100 mV	—	4	—	μ s

Package Information

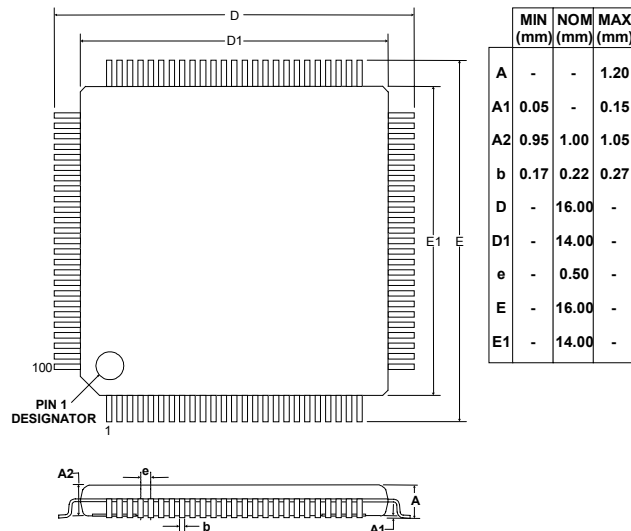

C8051F040DK Development Kit

