

Features

- Single-Turn / Carbon / Commercial Open Frame
- Cross slot rotor design suitable for automatic adjustment equipment
- Board retention feature
- Enclosed cover
- PC board stand-offs



Model 3318 is currently available, although not recommended for new designs. Models 3306F & 3306K are preferred.

- Adjustable front/back, top/bottom
- RoHS compliant*

3318 - 6 mm Square Trimming Potentiometer

Electrical Characteristics

Standard Resistance Range 100 to 1 megohm
 (see standard resistance table)
 Resistance Tolerance ±30 %
 (tighter tolerances available)
 Contact Resistance Variation...10 % max.
 Resolution Infinite
 Adjustment Angle 210° ±20°

Environmental Characteristics

Power Rating
 100-500K ohms50 V
 >500K ohms.....25 V
 50 °C0.1 watt
 Temperature Range... -25 °C to +100 °C
 Temperature Coefficient...±1000 ppm/°C
 Load Life.. 1,000 hours 0.1 watt @ 70 °C
 (20 % ΔTR)

Physical Characteristics

Torque (Operating)..... 20-250 g-cm
 Stop Strength
 Knob Side 750 g-cm
 Reverse Side 350 g-cm
 Terminals Solderable pins
 Marking..... Resistance code, date code
 Standard Packaging500 pcs. per bag
 Adjustment Tool..... H-90
 Aqueous cleaning not recommended

How To Order

3318 K - 1 - 103

Model _____
 Style _____
 Standard or Modified Product Code _____
 -1 = 30 % TR Tolerance (Standard)
 -2 = 20 % TR Tolerance
 Resistance Code _____
 Packaging Options _____
 Blank = 500 pcs./bag (Standard)
 A = Ammo Pack - 1000 pcs./box

Standard Resistance Table

Resistance (Ohms)	Resistance Code
100	101
200	201
500	501
1,000	102
2,000	202
5,000	502
10,000	103
20,000	203
50,000	503
100,000	104
200,000	204
500,000	504
1,000,000	105

Popular values listed in boldface. Others are typically not stocked by distributors and are not recommended for new designs.

*RoHS Directive 2002/95/EC Jan 27 2003 including Annex. Specifications are subject to change without notice.

Customers should verify actual device performance in their specific applications

Product Dimensions

3318K

FRONT VIEW

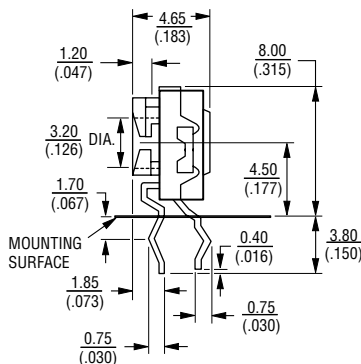
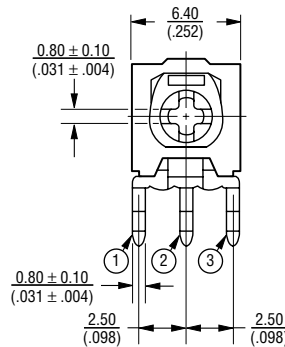

REAR VIEW

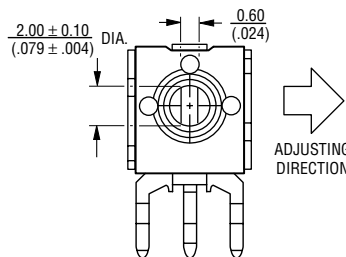

SUGGESTED PWB LAYOUT

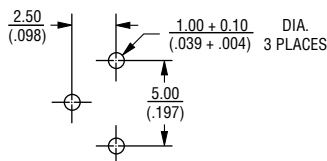

3318F

FRONT VIEW

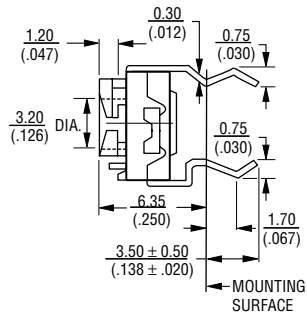
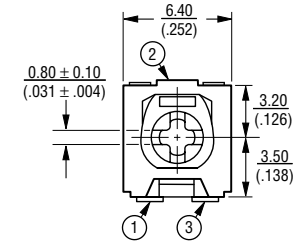

REAR VIEW

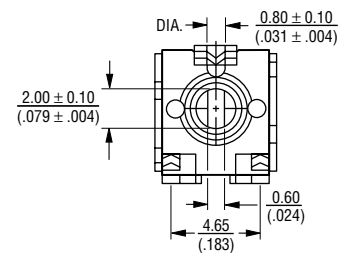

SUGGESTED PWB LAYOUT

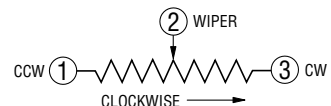
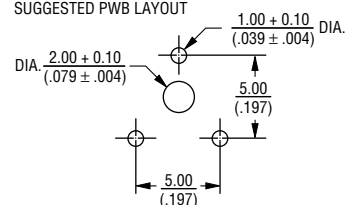

DIMENSIONS: $\frac{\text{MM}}{\text{(INCHES)}}$

TOLERANCES: ± $\frac{0.25}{(0.010)}$ EXCEPT WHERE NOTED

3318 - 6 mm Square Trimming Potentiometer

BOURNS®

Packaging Specifications

Ammo Pack Model 3318K

Recommended PCB Layout

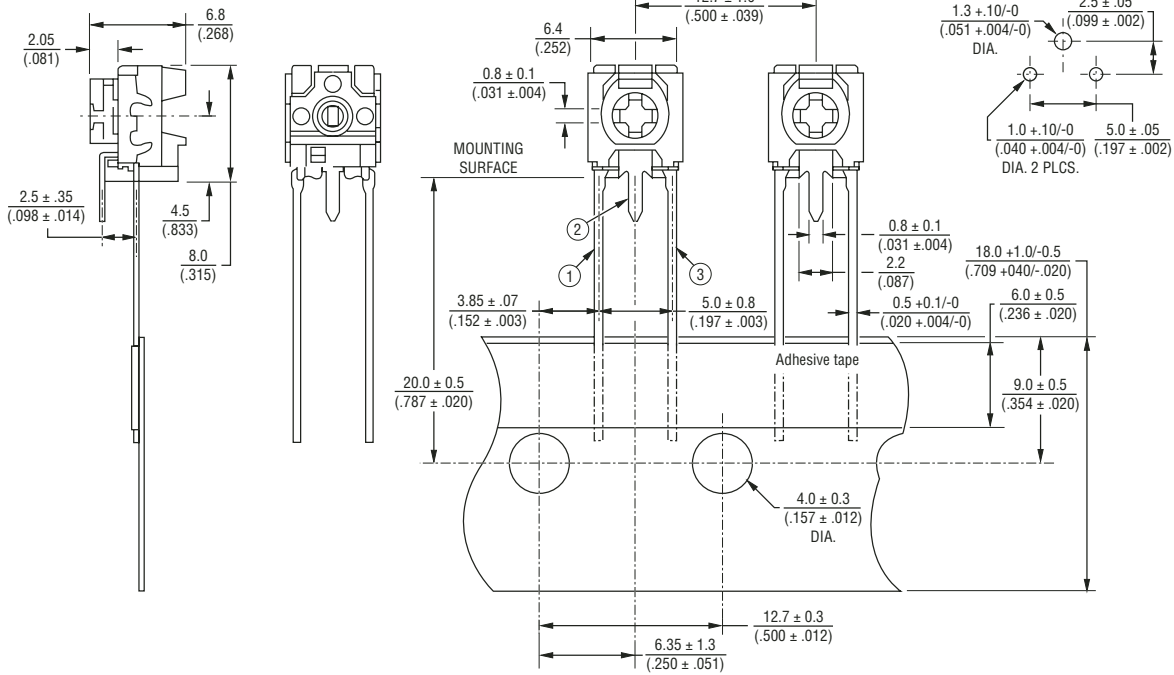

Ammo Pack Model 3318F

Recommended PCB Layout

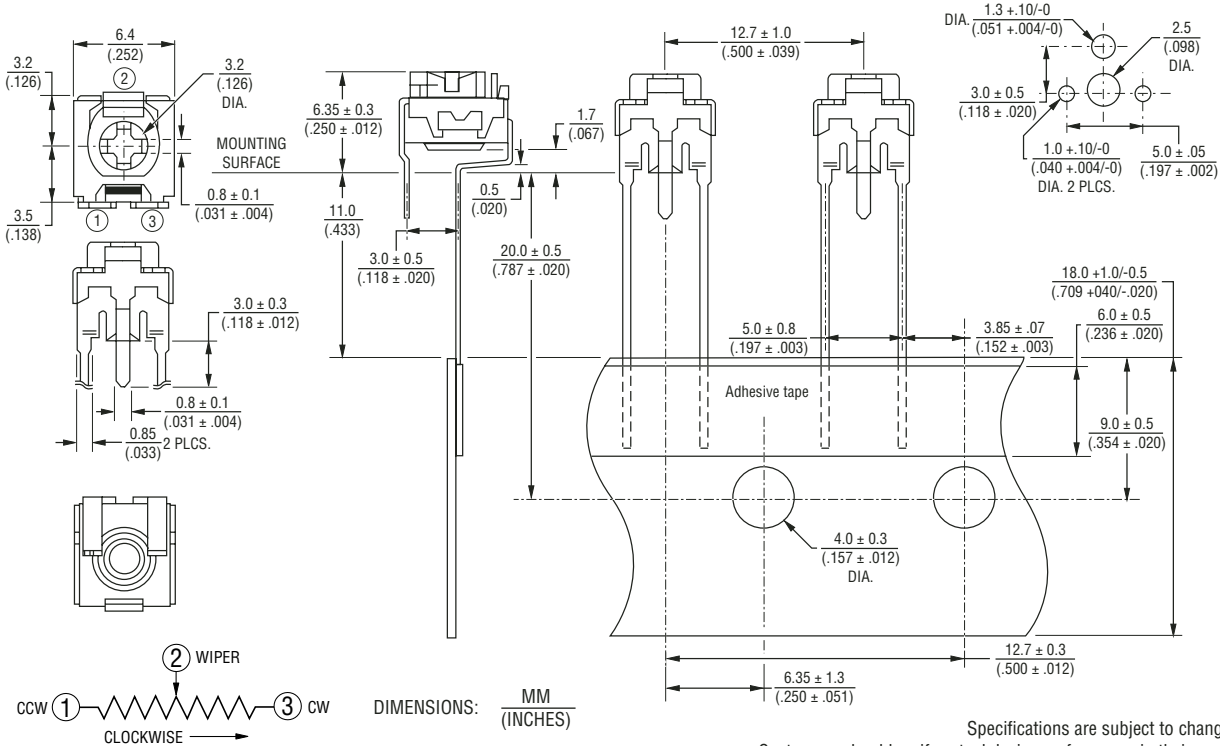

REV. 10/08

Specifications are subject to change without notice. Customers should verify actual device performance in their specific applications