

Preliminary

80W 9xxnm 30% Fill Factor High Power Laser Diode Bar on Passive Cu Block Cooler

BPC80C-9xx-01

The Bookham BPC80C-9xx-01 30% fill factor laser diode bar on passive cooler series has been designed to provide the increased brightness and reliability required for collimated pumping of next generation solid-state lasers and direct applications. The proprietary E2 front mirror passivation process, developed at our Zurich site, prevents Catastrophic Optical Damage (COD) to the laser diode facet even at extremely high output powers. The laser diode bars are mounted on an expansion matched CuW submount onto a Cu block package providing very high reliability in CW and pulsed (1-Hz type) applications.

Features:

- Mounted 10mm x 2.4mm laser diode bar
- Passive 1" x 1" Cu block cooler
- 30% fill factor (150µm emitter / 500µm pitch)
- 80W operating power
- Highly reliable single quantum well MBE structure
- Telecom-grade AuSn mounting technology
- Standard wavelengths at 915nm, 940nm, and 980nm (others available on request)
- RoHS compliant 

Applications:

- Collimated solid-state laser pumping
- Direct applications such as material processing
- Printing
- Medical



Characteristics

Parameter	Symbol	Typical	Unit
CW Output Power	P_{op}	80	W
Center Wavelength ^[1] BPC80C-915-01 BPC80C-940-01 BPC80C-980-01	λ_{c915} λ_{c940} λ_{c980}	915 ± 10 940 ± 10 980 ± 10	nm
Spectral Width (FWHM)	$\Delta\lambda$	3	nm
Wavelength Shift with Temperature	$d\lambda_c/dT_{op}$	0.3	nm/°C
Beam Divergence Parallel to Junction (90% of Power) Perpendicular to Junction (FWHM) Perpendicular to Junction (90% of Power)	$\theta_{//}$ θ_{\perp} θ_{\perp}	7 26 60	deg
Polarization	–	TE	–
Threshold Current	I_{th}	8	A
Slope Efficiency	$\eta_D = P_{op}/(I_{op} - I_{th})$	1	W/A
Conversion Efficiency	$H = P_{op}/(V_{op} \times I_{op})$	60	%
Series Resistance	R_s	5	mΩ
Operating Current	I_{op}	85	A
Operating Voltage	V_{op}	1.5	V
Operating Temperature	T_{op}	25 ± 5	°C

[1] Reduced wavelength window / extended range available on request (900-1060nm).

Bar Dimensions

Parameter	Symbol	Typical	Unit
Bar Width	b	10	mm
Resonator Length	l	2.4	mm
Number of Emitters	n	19	–
Emitter Spacing	p	500	μm
Emission Width	w	150	μm
Fill Factor	f	30	%

Passive Cu Block Cooler Dimensions (mm)

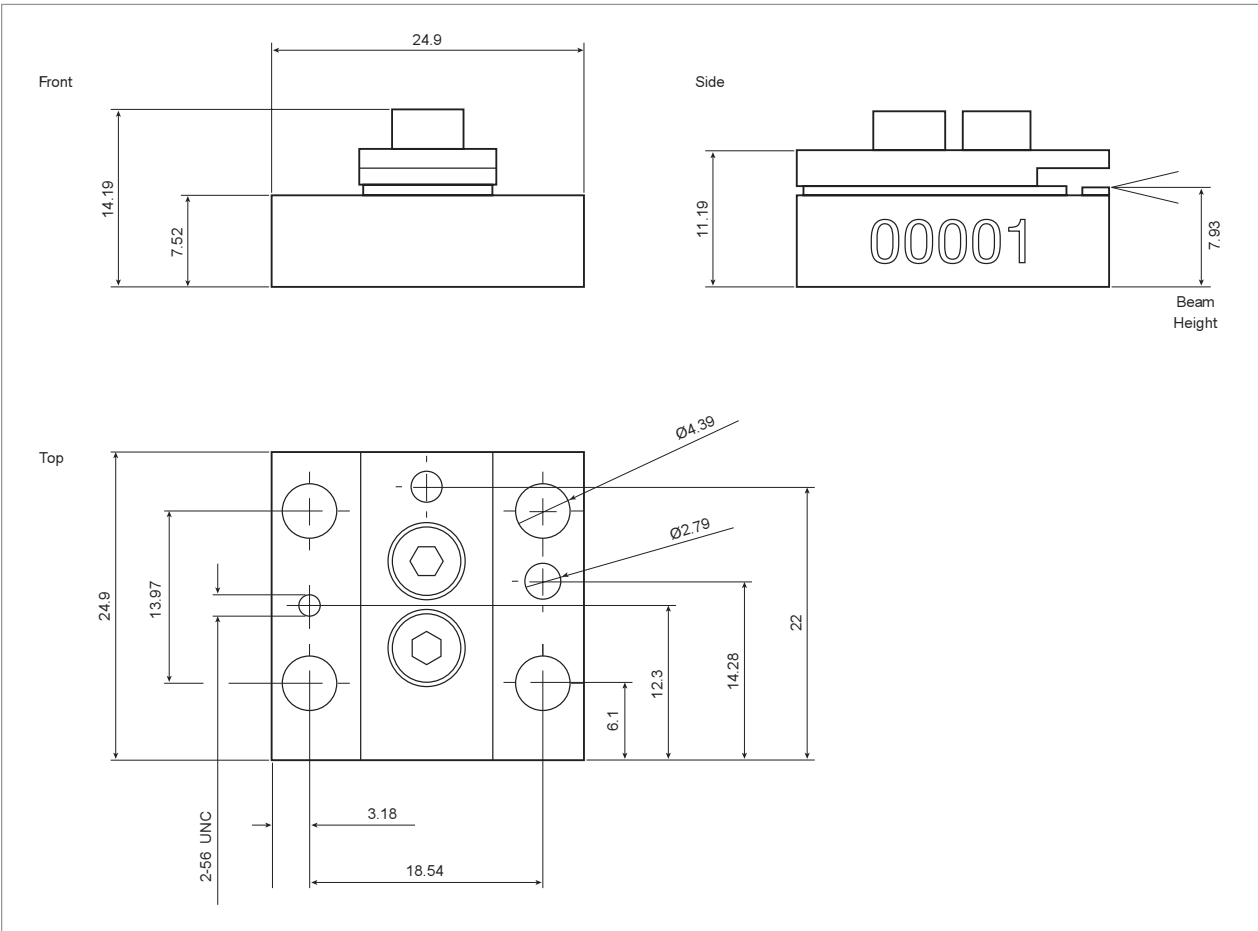

RoHS Compliance



Bookham is fully committed to environment protection and sustainable development and has set in place a comprehensive program for removing polluting and hazardous substances from all of its products. The relevant evidence of RoHS compliance is held as part of our controlled documentation for each of our compliant products. RoHS compliance parts are available to order, please refer to the ordering information section for further details.

Ordering Information:

BPC80C-915-01	80W 915nm 30% Fill Factor Laser Diode Bar on Passive Cu Block Cooler
BPC80C-940-01	80W 940nm 30% Fill Factor Laser Diode Bar on Passive Cu Block Cooler
BPC80C-980-01	80W 980nm 30% Fill Factor Laser Diode Bar on Passive Cu Block Cooler

Contact Information

Bookham (Switzerland) AG

Binzstrasse 17
8045 Zurich
Switzerland

- Tel: +41 44 455 8787
- Fax: +41 44 455 8586

www.bookham.com
highpower@bookham.com

EMEA Sales Contact

Gunnar Stolze
• Tel: +41 79 635 3777

North America Sales Contact

Michael Cutler
• Tel: +1 678 763 0777

ASIA Sales Contact

Patrick Lee
• Tel: +852 9197 7014

Japan Sales Contact

Japan Laser Corporation
• Tel: +813 5285 0861

Important Notice

Performance figures, data and any illustrative material provided in this data sheet are typical and must be specifically confirmed in writing by Bookham before they become applicable to any particular order or contract. In accordance with the Bookham policy of continuous improvement specifications may change without notice. The publication of information in this data sheet does not imply freedom from patent or other protective rights of Bookham or others. Further details are available from any Bookham sales representative.

