

THE INFORMATION CONTAINED HEREIN IS CONSIDERED "PROPRIETARY" TO BEL FUSE INC. AND SHALL NOT BE COPIED, REPRODUCED OR DISCLOSED WITHOUT THE WRITTEN APPROVAL OF BEL FUSE INC.



SCHEMATIC

ELECTRICAL CHARACTERISTICS @ 25°C

RETURN LOSS (MIN.)		
1MHz-30MHz	-18 dB	
60MHz-80MHz	-12 dB	
INSERTION LOSS(MAX)		
100KHz TO 100MHz	-1.1 dB	
OCL @ 0.1V, 100KHz		
8mA DC BIAS	350μH MIN.	
URNS RATIO	1CT : 1CT ±3%	
XTALK		
100KHz TO 100MHz	-35 dB MIN.	

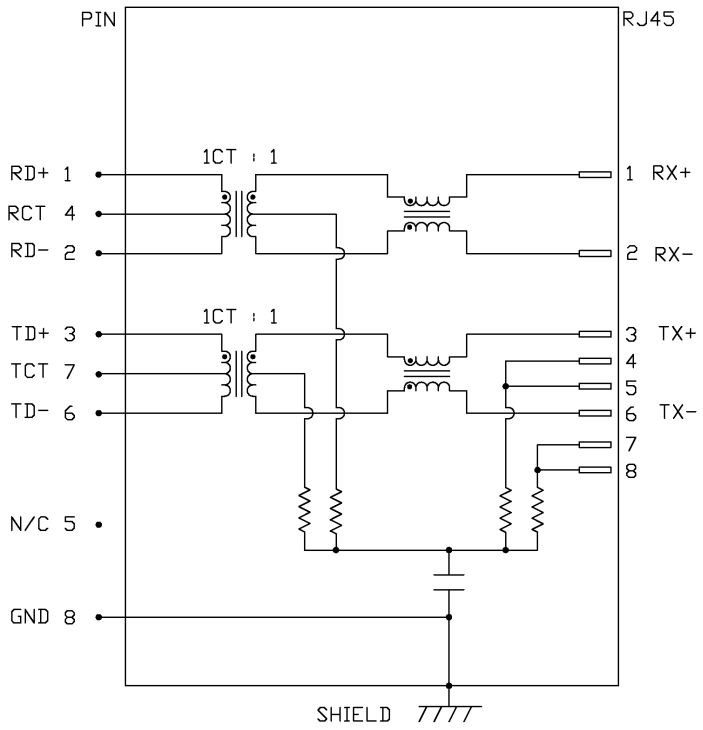

ORIGINATED BY	DATE	TITLE	PART NO. / DRAWING NO.	STANDARD DIM.	[] METRIC DIM. AS REFERENCE	 <small>COMPONENTS ON A CONNECTED PLANET</small>	
CHUNG	06-02-05	2X4 MagJack® (4 Cores) 0811-2X4R-28-F	08112X4R28-F	TOL. IN INCH	UNIT : INCH [mm]		REV. : A
DRAWN BY	DATE		FILE NAME	.X	SCALE : N/A		SIZE : A4
DE	06-02-05		08112X4R28-FA.DWG	.XX			PAGE : 2
				.XXX			

DC002(2)122004 This document is electronically generated. This is a controlled copy if used internally

THE INFORMATION CONTAINED HEREIN IS CONSIDERED "PROPRIETARY" TO BEL FUSE INC. AND SHALL NOT BE COPIED, REPRODUCED OR DISCLOSED WITHOUT THE WRITTEN APPROVAL OF BEL FUSE INC.

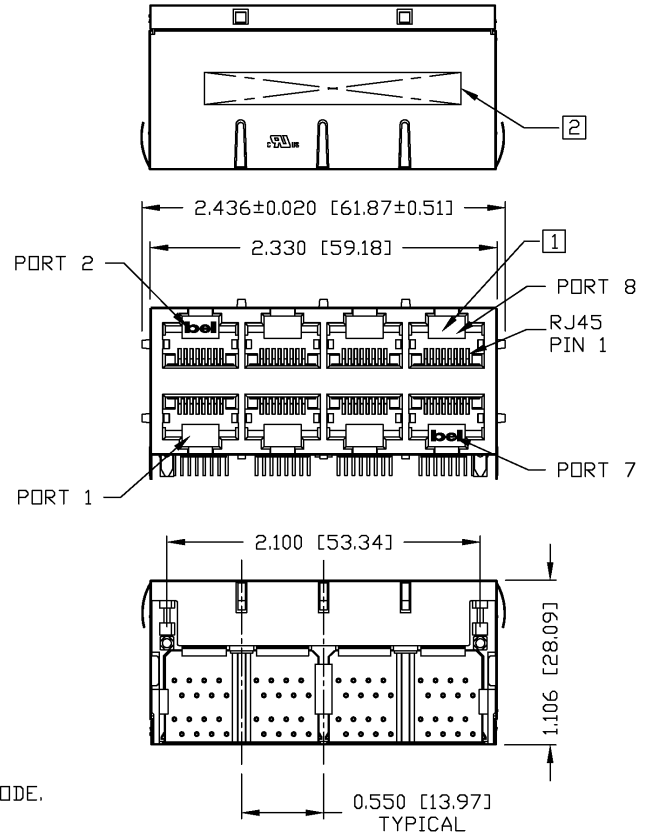
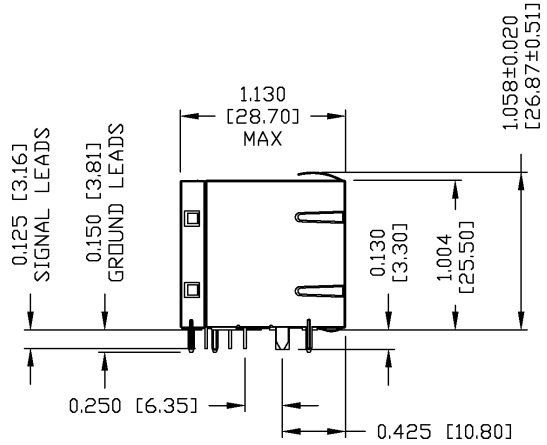

NOTES:

PLASTIC HOUSING: THERMOPLASTIC PBT
 FLAMMABILITY RATING UL 94V-0
 CONTACT PLATING: 30 MICRO-INCH HARD GOLD PLATING
 OUTPUT PINS: TIN-COATED COPAR WIRE, DIA 0.018 INCH.
 METAL SHIELD: NICKEL PLATED COPAR ALLOY.
 (ALL GROUND LEADS ARE SOLDER DIPAD)

- 1. JACK CAVITY CONFORMS TO FCC RULES AND REGULATIONS, PART 68 SUBPART F.
- 2. MARK PART WITH MFG LOGO, MFG NAME, PART NUMBER, AND DATE CODE.

UL UL RECOGNIZED - FILE #E196366 AND E169987.
 RoHS COMPLIANCE, PER EU DIRECTIVE 2002/95/EC.

ORIGINATED BY	DATE	TITLE	PART NO. / DRAWING NO.	STANDARD DIM. TOL. IN INCH	[] METRIC DIM. AS REFERENCE
BILL	06-02-05	2X4 MagJack® (4 Cores) 0811-2X4R-28-F	08112X4R28-F	.X	UNIT : INCH [mm] REV. : A
DRAWN BY	DATE		FILE NAME	.XX	SCALE : N/A SIZE : A4
LING	06-02-05		08112X4R28-FA.DWG	.XXX ±0.010	PAGE : 3



DC002(2)122004 This document is electronically generated. This is a controlled copy if used internally

THE INFORMATION CONTAINED HEREIN IS CONSIDERED "PROPRIETARY" TO BEL FUSE INC. AND SHALL NOT BE COPIED, REPRODUCED OR DISCLOSED WITHOUT THE WRITTEN APPROVAL OF BEL FUSE INC.



PORT ASSIGNMENT
(COMPONENT SIDE VIEW)

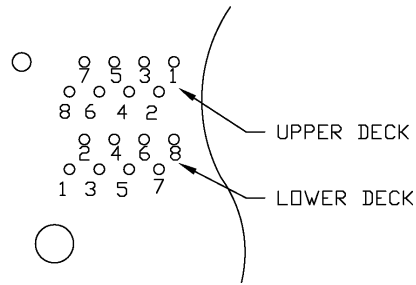
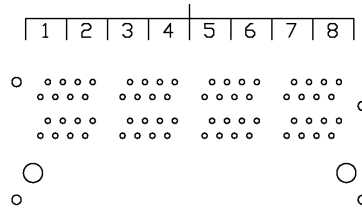

PIN-OUT INFORMATION
(COMPONENT SIDE VIEW)

8	GND
7	TCT
6	TD-
5	NC
4	RCT
3	TD +
2	RD -
1	RD +

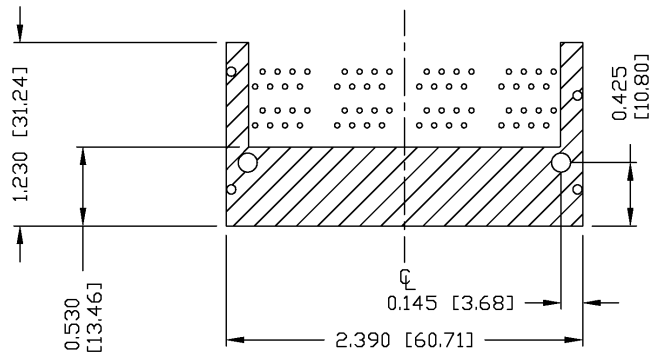

THE SHADED AREA ON THE CUSTOMER BOARD ARE RECOMMENDED TO BE CLEAR OFF ANY VIA HOLE OR COMPONENT PAD.

ORIGINATED BY	DATE	TITLE	PART NO. / DRAWING NO.	STANDARD DIM. TOL. IN INCH	[] METRIC DIM. AS REFERENCE
BILL	06-02-05	2X4 MagJack® (4 Cores) 0811-2X4R-28-F	08112X4R28-F	.X	UNIT : INCH [mm] REV. : A
DRAWN BY	DATE		FILE NAME	.XX	SCALE : N/A SIZE : A4
LING	06-02-05		08112X4R28-FA.DWG	.XXX ±0.010	PAGE : 4



DC002(2)122004 This document is electronically generated. This is a controlled copy if used internally

THE INFORMATION CONTAINED HEREIN IS CONSIDERED "PROPRIETARY" TO BEL FUSE INC. AND SHALL NOT BE COPIED, REPRODUCED OR DISCLOSED WITHOUT THE WRITTEN APPROVAL OF BEL FUSE INC.

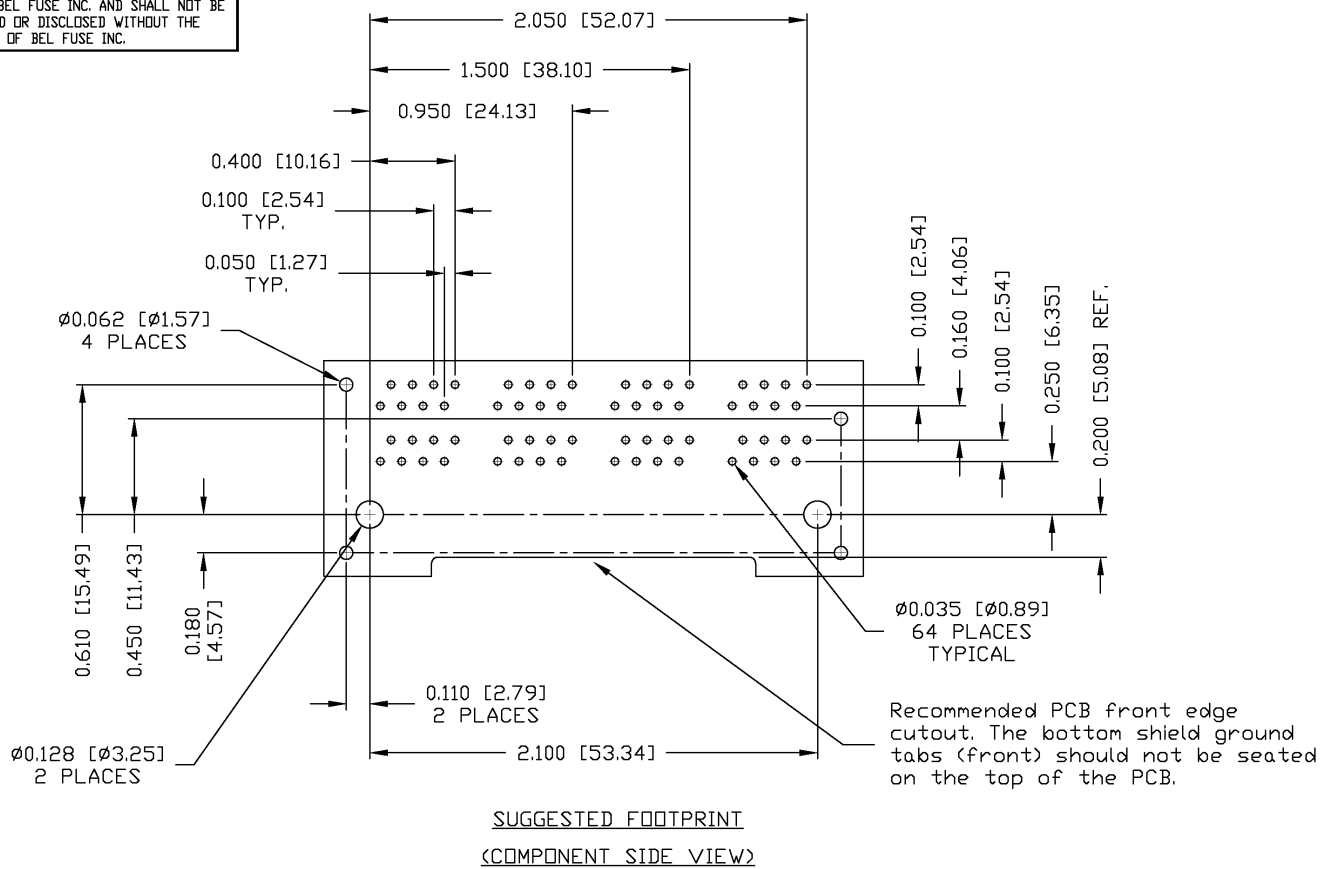

ORIGINATED BY	DATE	TITLE	PART NO. / DRAWING NO.	STANDARD DIM. TOL. IN INCH	[] METRIC DIM. AS REFERENCE
BILL	06-02-05	2X4 MagJack® (4 Cores) 0811-2X4R-28-F	08112X4R28-F	.X	UNIT : INCH [mm] REV. : A
DRAWN BY	DATE		FILE NAME	.XX	SCALE : N/A SIZE : A4
LING	06-02-05		08112X4R28-FA.DWG	.XXX ±0.005	PAGE : 5



DC002(2)122004 This document is electronically generated. This is a controlled copy if used internally

THE INFORMATION CONTAINED HEREIN IS CONSIDERED "PROPRIETARY" TO BEL FUSE INC. AND SHALL NOT BE COPIED, REPRODUCED OR DISCLOSED WITHOUT THE WRITTEN APPROVAL OF BEL FUSE INC.



SUGGESTED PANEL DANING

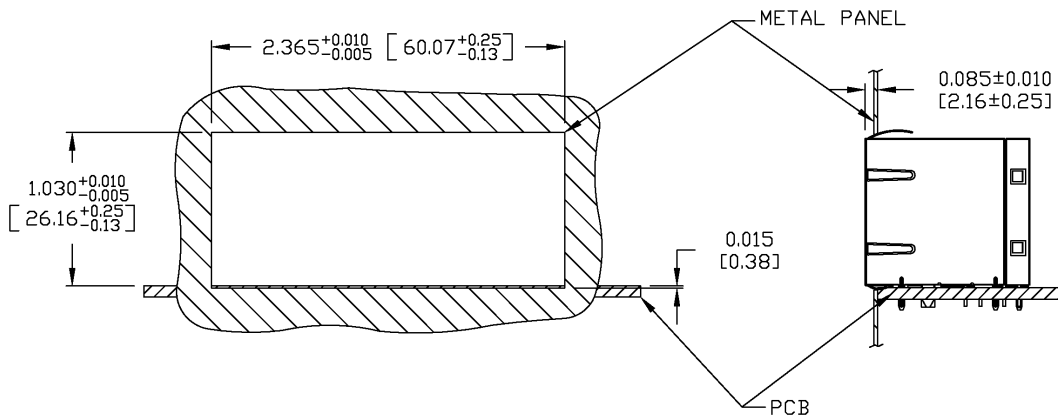

NOTES:

THE DISTANCE OF PANEL INSIDE SURFACE RELATIVE TO FRONT SURFACE OF PART IS ONLY A SUGGESTION. IN CASE THIS DISTANCE IS DIFFERENT, THE REQUIRED PANEL DANING DIMENSIONS CHANGE ACCORDINGLY.

PACKING INFORMATION

PACKING TRAY : 0200-0148-46 (TOP)
0200-0148-47 (BOTTOM)

PACKING QUANTITY : 20 PCS FINISHED GOODS AR TRAY.
7 TRAYS (140 PCS FINISHED GOODS) AR CARTON BOX.

NOTE : CARDBOARDS ARE PLACED BETWEEN LAYERS OF PACKING TRAY INSIDE CARTON BOX.
(INCLUDE THE UPARMOST AND LOWERMOST TRAY)

ORIGINATED BY	DATE	TITLE	PART NO. / DRAWING NO.	STANDARD DIM. TOL. IN INCH	[] METRIC DIM. AS REFERENCE
BILL	06-02-05	2X4 MagJack® (4 Cores) 0811-2X4R-28-F	08112X4R28-F	.X	UNIT : INCH [mm] REV. : A
DRAWN BY	DATE		FILE NAME	.XX	SCALE : N/A SIZE : A4
LING	06-02-05		08112X4R28-FA.DWG	.XXX ±0.004	PAGE : 6



DC002(2)122004 This document is electronically generated. This is a controlled copy if used internally