

PH CONNECTOR

Disconnectable Crimp style connectors

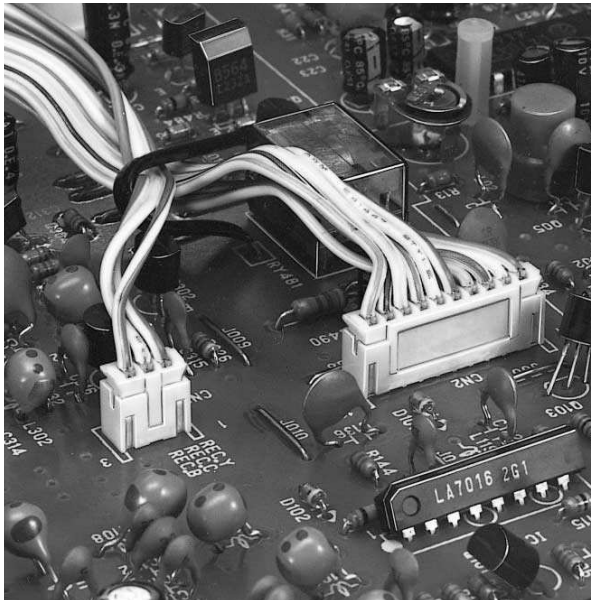

This is a thin, low-profile 2.0mm (.079") pitch connector 7.5mm (.295") in height after mounting and 4.5mm (.177") in width. It is designed to meet the demand for high-density connection of internal wires to printed circuit boards. It is compact, highly reliable and low in cost.

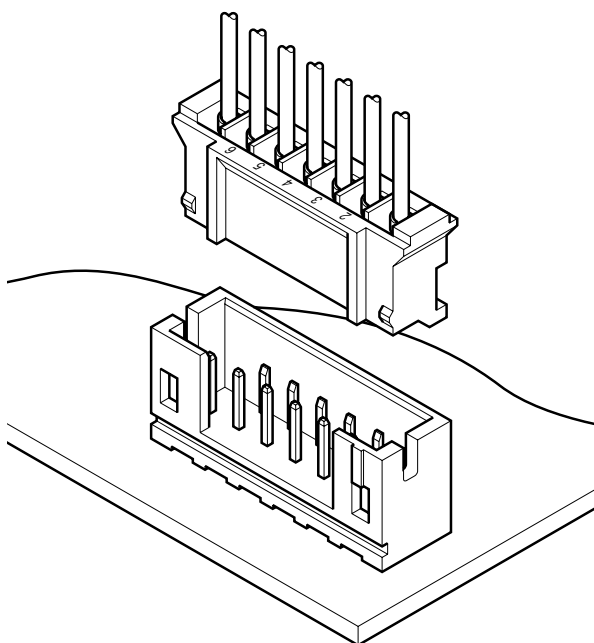

Features

• **Reliable contact**

The contact has long dimples near the center to ensure a good connection at all times, even under conditions of vibration and mechanical abuse, and when used with low voltage and low current circuits.

• **Fully shrouded header**

The fully shrouded header has walls on all four sides to prevent improper connection to the mating housing and to prevent the instruction of flux and other contaminants.

• **Printed circuit board retention mechanism**

The solder side of the header has a retention mechanism that prevents it from floating during soldering. As a result, the header can be positioned accurately.

• **Surface mount model (SMT)**

This connector is also available in a surface mount configuration. Its housing is made of heat resistant resin so that it is not adversely affected during reflow soldering. Because of its tiny size and ability to be surface mounted, this connector meets the demand for high-density mounting of components inside electronic products.

Specifications

- Current rating: 2A AC, DC (AWG #24)
- Voltage rating: 100V AC, DC
- Temperature range: -25°C to +85°C
(including temperature rise in applying electrical current)
- Contact resistance: Initial value/10m Ω max.
After environmental testing/20m Ω max.
- Insulation resistance: 1,000M Ω min.
- Withstanding voltage: 800V AC/minute
- Applicable wire: AWG #32 to #24
- Applicable PC board thickness: 0.8 to 1.6mm (.031" to .063")
- * Contact JST if Lead-Free product is required.
- * Refer to "General Instruction and Notice when using Terminals and Connectors" at the end of this catalog.
- * Contact JST for details.

Standards

- Ⓡ Recognized E60389
- Ⓢ Certified LR20812
- Ⓡ R75087

PH CONNECTOR

Contact

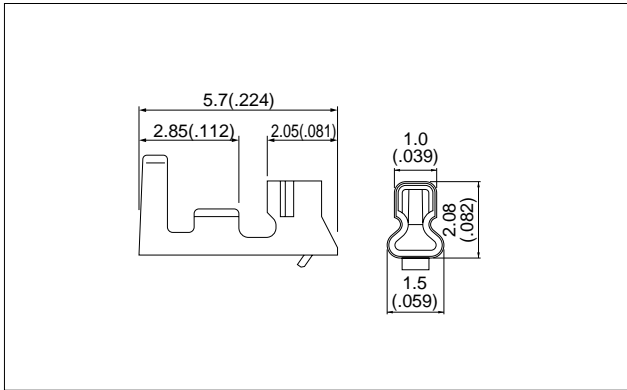

Model No.	Applicable wire			Q'ty / reel
	mm ²	AWG #	Insulation O.D. mm(in.)	
SPH-002T-P0.5S	0.05 to 0.22	30 to 24	0.9 to 1.5(.035 to .059)	8,000
SPH-002T-P0.5L	0.08 to 0.22	28 to 24	0.8 to 1.5(.031 to .059)	8,000
SPH-004T-P0.5S	0.032 to 0.08	32 to 28	0.5 to 0.9(.020 to .035)	10,000

Material and Finish

Phosphor bronze, tin-plated

Note:

1. Contact JST for gold-plated contacts.
2. SPH-002T-P0.5L is low-insertion force type contact, for easier insertion/withdrawal, which would be less resistant to the vibration. The crimp height is different from the standard.
3. When using AWG#32 or #30 wires, reflow-treated headers (Low insertion force type, Model No. B#B-PH-KL or S#B-PH-KL) are recommendable.
4. Contact JST for details.

Housing

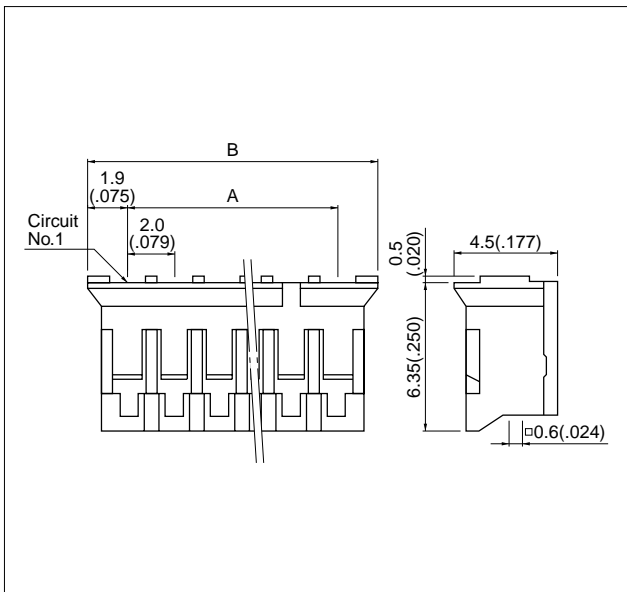

Circuits	Model No.	Dimensions mm(in.)		Q'ty / box
		A	B	
2	PHR- 2	2.0(.079)	5.8(.228)	1,000
3	PHR- 3	4.0(.157)	7.8(.307)	1,000
4	PHR- 4	6.0(.236)	9.8(.386)	1,000
5	PHR- 5	8.0(.315)	11.8(.465)	1,000
6	PHR- 6	10.0(.394)	13.8(.543)	1,000
7	PHR- 7	12.0(.472)	15.8(.622)	1,000
8	PHR- 8	14.0(.551)	17.8(.701)	1,000
9	PHR- 9	16.0(.630)	19.8(.780)	1,000
10	PHR-10	18.0(.709)	21.8(.858)	1,000
11	PHR-11	20.0(.787)	23.8(.937)	1,000
12	PHR-12	22.0(.866)	25.8(1.016)	1,000
13	PHR-13	24.0(.945)	27.8(1.094)	1,000
14	PHR-14	26.0(1.024)	29.8(1.173)	1,000
15	PHR-15	28.0(1.102)	31.8(1.252)	1,000
16	PHR-16	30.0(1.181)	33.8(1.331)	1,000

Material

Nylon 66, UL94V-0, natural (white)

<For reference> As the color identification, the following alphabet shall be put in the underlined part.
For availability, delivery and minimum order quantity, contact JST.

ex. **PHR-2-oo**

(blank)...natural (white)

BK...black R...red TR...tomato red BL...blue Y...yellow

L...lemon yellow M...green D...orange N...brown

P...purple PK...pink H...gray LE...light blue

FY...vivid yellow

Through-hole type shrouded header

The shrouded headers are interchangeable with those of the KR, KR D and CR insulation displacement connectors.

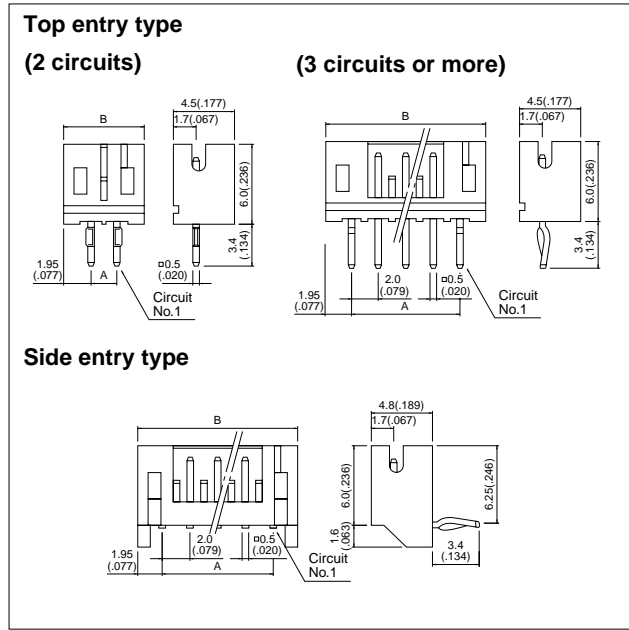

Circuits	Model No.		Dimensions mm(in.)		Q'ty / box	
	Top entry type	Side entry type	A	B	Top entry type	Side entry type
2	B 2B-PH-K-S	S 2B-PH-K-S	2.0 (.079)	5.9 (.232)	1,000	1,000
3	B 3B-PH-K-S	S 3B-PH-K-S	4.0 (.157)	7.9 (.311)	1,000	1,000
4	B 4B-PH-K-S	S 4B-PH-K-S	6.0 (.236)	9.9 (.390)	1,000	500
5	B 5B-PH-K-S	S 5B-PH-K-S	8.0 (.315)	11.9 (.469)	1,000	500
6	B 6B-PH-K-S	S 6B-PH-K-S	10.0 (.394)	13.9 (.547)	1,000	500
7	B 7B-PH-K-S	S 7B-PH-K-S	12.0 (.472)	15.9 (.626)	500	500
8	B 8B-PH-K-S	S 8B-PH-K-S	14.0 (.551)	17.9 (.705)	500	250
9	B 9B-PH-K-S	S 9B-PH-K-S	16.0 (.630)	19.9 (.783)	500	250
10	B10B-PH-K-S	S10B-PH-K-S	18.0 (.709)	21.9 (.862)	500	250
11	B11B-PH-K-S	S11B-PH-K-S	20.0 (.787)	23.9 (.941)	500	250
12	B12B-PH-K-S	S12B-PH-K-S	22.0 (.866)	25.9 (1.020)	500	250
13	B13B-PH-K-S	S13B-PH-K-S	24.0 (.945)	27.9 (1.098)	250	250
14	B14B-PH-K-S	S14B-PH-K-S	26.0 (1.024)	29.9 (1.177)	250	250
15	B15B-PH-K-S	S15B-PH-K-S	28.0 (1.102)	31.9 (1.256)	250	200
16	B16B-PH-K-S	S16B-PH-K-S	30.0 (1.181)	33.9 (1.335)	250	200

Material and Finish

Post: Brass, copper-undercoated, tin/lead-plated
Wafer: Nylon 66, UL94V-0, natural (white)

<For reference> As the color identification, the following alphabet shall be put in the underlined part.
For availability, delivery and minimum order quantity, contact JST.

- ex. **B2B-PH-K-oo**
 S...natural (white)
 K...black R...red TR...tomato red
 E...blue Y...yellow L...lemon yellow M...green
 O...orange N...brown P...purple PK...pink H...gray
 LE...light blue FY...vivid yellow (blank)...ivory

PH CONNECTOR

Through-hole type shrouded header <Low insertion force type>

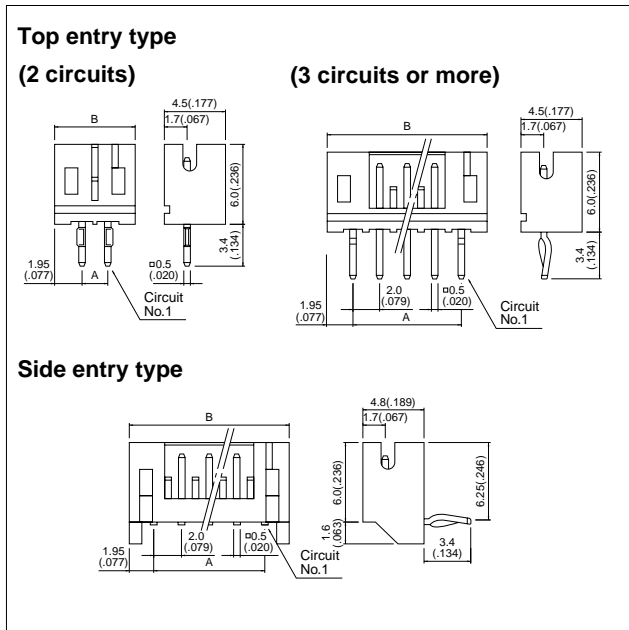

Circuits	Model No.		Dimensions mm(in.)		Q'ty / box	
	Top entry type	Side entry type	A	B	Top entry type	Side entry type
2	B 2B-PH-KL	S 2B-PH-KL	2.0(.079)	5.9(.232)	1,000	1,000
3	B 3B-PH-KL	S 3B-PH-KL	4.0(.157)	7.9(.311)	1,000	1,000
4	B 4B-PH-KL	S 4B-PH-KL	6.0(.236)	9.9(.390)	1,000	500
5	B 5B-PH-KL	S 5B-PH-KL	8.0(.315)	11.9(.469)	1,000	500
6	B 6B-PH-KL	S 6B-PH-KL	10.0(.394)	13.9(.547)	1,000	500
7	B 7B-PH-KL	S 7B-PH-KL	12.0(.472)	15.9(.626)	500	500
8	B 8B-PH-KL	S 8B-PH-KL	14.0(.551)	17.9(.705)	500	250
9	B 9B-PH-KL	S 9B-PH-KL	16.0(.630)	19.9(.783)	500	250
10	B10B-PH-KL	S10B-PH-KL	18.0(.709)	21.9(.862)	500	250
11	B11B-PH-KL	S11B-PH-KL	20.0(.787)	23.9(.941)	500	250
12	B12B-PH-KL	S12B-PH-KL	22.0(.866)	25.9(1.020)	500	250
13	B13B-PH-KL	S13B-PH-KL	24.0(.945)	27.9(1.098)	250	250
14	B14B-PH-KL	S14B-PH-KL	26.0(1.024)	29.9(1.177)	250	200
15	B15B-PH-KL	S15B-PH-KL	28.0(1.102)	31.9(1.256)	250	200
16	B16B-PH-KL	S16B-PH-KL	30.0(1.181)	33.9(1.335)	250	200

Material and Finish

Post: Copper alloy, copper-undercoated, tin/lead-plated (reflow-treated)
 Wafer: Nylon 66, UL94V-0, gray

<For reference> As the color identification, the following alphabet shall be put in the underlined part.
 For availability, delivery and minimum order quantity, contact JST.

ex. **B2B-PH-KL-oo**
 (blank)...gray
 R...red E...blue S...natural (white)

Through-hole type PC board layout (viewed from soldering side) and Assembly layout

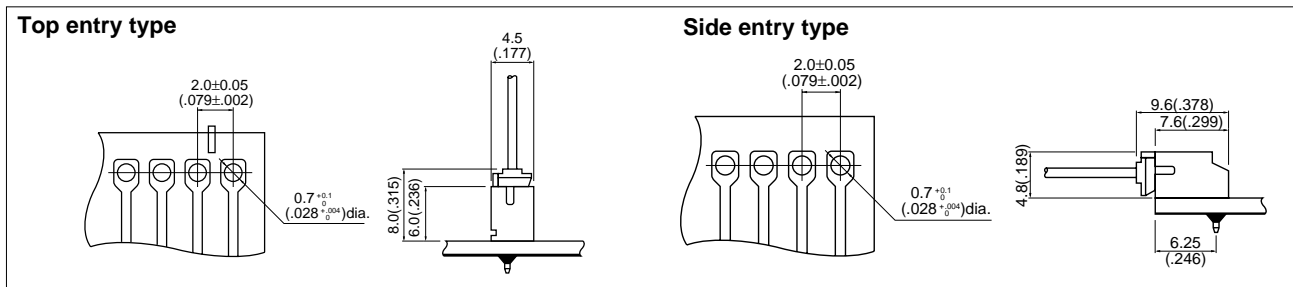

Note:

1. Tolerances are non-cumulative: $\pm 0.05\text{mm}(\pm .002")$ for all centers.
2. Hole dimensions differ according to the kind of printed circuit board and piercing method. If printed circuit boards made of hard material are used, the hole dimensions should be larger. The hole dimensions shown above are reference values. Contact JST for details.

SMT type shrouded header

•The shrouded headers are interchangeable with those of the KR, KRd and CR insulation displacement connectors.

•SMT type shrouded headers are not TÜV approved.

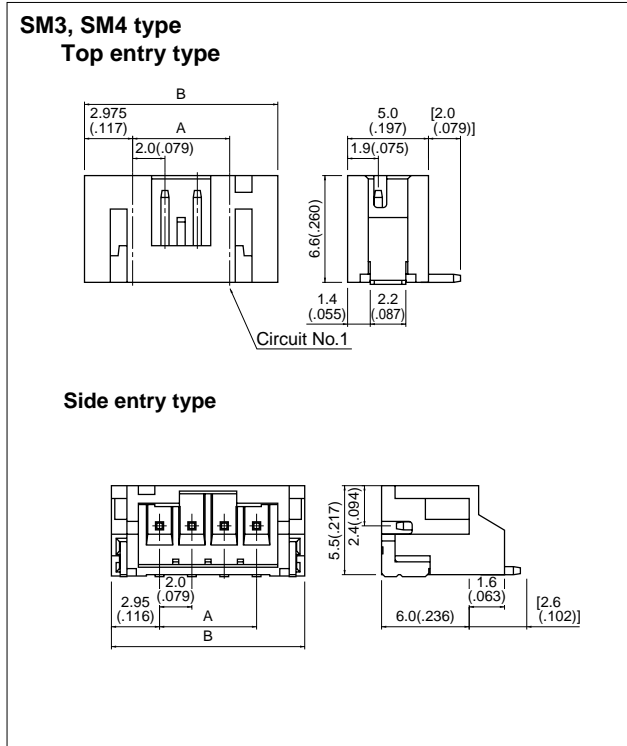

SM3 type

Circuits	Model No.		Dimensions mm(in.)			Qty / reel
	Top entry type	Side entry type	A	B		
				Top entry type	Side entry type	
2	B 2B-PH-SM3-TB	S 2B-PH-SM3-TB	2.0(.079)	7.95(.313)	7.9(.311)	1,000
3	B 3B-PH-SM3-TB	S 3B-PH-SM3-TB	4.0(.157)	9.95(.392)	9.9(.390)	1,000
4	B 4B-PH-SM3-TB	S 4B-PH-SM3-TB	6.0(.236)	11.95(.470)	11.9(.469)	1,000
5	B 5B-PH-SM3-TB	S 5B-PH-SM3-TB	8.0(.315)	13.95(.549)	13.9(.547)	1,000
6	B 6B-PH-SM3-TB	S 6B-PH-SM3-TB	10.0(.394)	15.95(.628)	15.9(.626)	1,000
7	B 7B-PH-SM3-TB	S 7B-PH-SM3-TB	12.0(.472)	17.95(.707)	17.9(.705)	1,000
8	B 8B-PH-SM3-TB	S 8B-PH-SM3-TB	14.0(.551)	19.95(.785)	19.9(.783)	1,000
9	B 9B-PH-SM3-TB	S 9B-PH-SM3-TB	16.0(.630)	21.95(.864)	21.9(.862)	1,000
10	B10B-PH-SM3-TB	S10B-PH-SM3-TB	18.0(.709)	23.95(.943)	23.9(.941)	1,000
11	B11B-PH-SM3-TB	-	20.0(.787)	25.95(1.022)	25.9(1.020)	1,000
12	B12B-PH-SM3-TB	S12B-PH-SM3-TB	22.0(.866)	27.95(1.100)	27.9(1.098)	1,000
13	B13B-PH-SM3-TB	S13B-PH-SM3-TB	24.0(.945)	29.95(1.179)	29.9(1.177)	1,000
14	B14B-PH-SM3-TB	S14B-PH-SM3-TB	26.0(1.024)	31.95(1.258)	31.9(1.256)	1,000
15	B15B-PH-SM3-TB	S15B-PH-SM3-TB	28.0(1.102)	33.95(1.337)	33.9(1.335)	1,000
16	B16B-PH-SM3-TB	-	30.0(1.181)	35.95(1.415)	35.9(1.413)	1,000

Material and Finish

Post: Copper alloy, copper-undercoated, tin/lead-plated
 Wafer: Nylon 46, UL94V-0, natural (white)
 Solder tab: Brass, copper-undercoated, tin/lead-plated

Note: Contact JST for the top entry type headers with suction cap.

SM4 type

Circuits	Model No.		Dimensions mm(in.)			Qty / reel
	Top entry type	Side entry type	A	B		
				Top entry type	Side entry type	
2	B 2B-PH-SM4-TB	S 2B-PH-SM4-TB	2.0(.079)	7.95(.313)	7.9(.311)	1,000
3	B 3B-PH-SM4-TB	S 3B-PH-SM4-TB	4.0(.157)	9.95(.392)	9.9(.390)	1,000
4	B 4B-PH-SM4-TB	S 4B-PH-SM4-TB	6.0(.236)	11.95(.470)	11.9(.469)	1,000
5	B 5B-PH-SM4-TB	S 5B-PH-SM4-TB	8.0(.315)	13.95(.549)	13.9(.547)	1,000
6	B 6B-PH-SM4-TB	S 6B-PH-SM4-TB	10.0(.394)	15.95(.628)	15.9(.626)	1,000
7	B 7B-PH-SM4-TB	S 7B-PH-SM4-TB	12.0(.472)	17.95(.707)	17.9(.705)	1,000
8	B 8B-PH-SM4-TB	S 8B-PH-SM4-TB	14.0(.551)	19.95(.785)	19.9(.783)	1,000
9	B 9B-PH-SM4-TB	S 9B-PH-SM4-TB	16.0(.630)	21.95(.864)	21.9(.862)	1,000
10	B10B-PH-SM4-TB	S10B-PH-SM4-TB	18.0(.709)	23.95(.943)	23.9(.941)	1,000
11	B11B-PH-SM4-TB	S11B-PH-SM4-TB	20.0(.787)	25.95(1.022)	25.9(1.020)	1,000
12	B12B-PH-SM4-TB	S12B-PH-SM4-TB	22.0(.866)	27.95(1.100)	27.9(1.098)	1,000
13	B13B-PH-SM4-TB	S13B-PH-SM4-TB	24.0(.945)	29.95(1.179)	29.9(1.177)	1,000
14	B14B-PH-SM4-TB	S14B-PH-SM4-TB	26.0(1.024)	31.95(1.258)	31.9(1.256)	1,000
15	B15B-PH-SM4-TB	S15B-PH-SM4-TB	28.0(1.102)	33.95(1.337)	33.9(1.335)	1,000
16	B16B-PH-SM4-TB	-	30.0(1.181)	35.95(1.415)	-	1,000

Material and Finish

Post: Copper alloy, copper-undercoated, tin-plated
 Wafer: 6T nylon, UL94V-0, natural (white)
 Solder tab: Brass, nickel-undercoated, tin/copper alloy-plated

Note: Contact JST for the top entry type headers with suction cap.

<For reference> As the color identification, the following alphabet shall be put in the underlined part. For availability, delivery and minimum order quantity, contact JST.

ex. B2B-PH-SM3-oo-TB

(blank)...natural (white)

R...red E...blue M...green L...lemon yellow K...black

PH CONNECTOR

Taping specifications

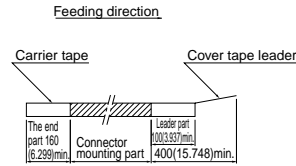
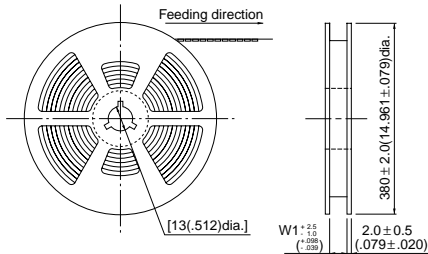

Top entry type (2 to 6 circuits)

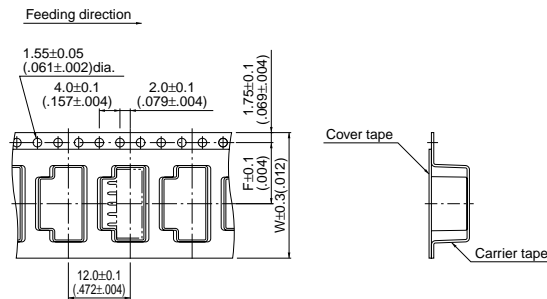

Top entry type (7 to 16 circuits)

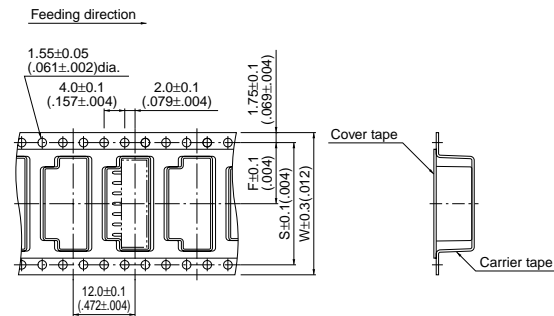

Side entry type (2 to 6 circuits)

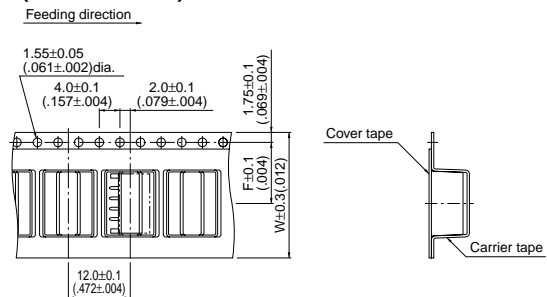

Side entry type (7 to 15 circuits)

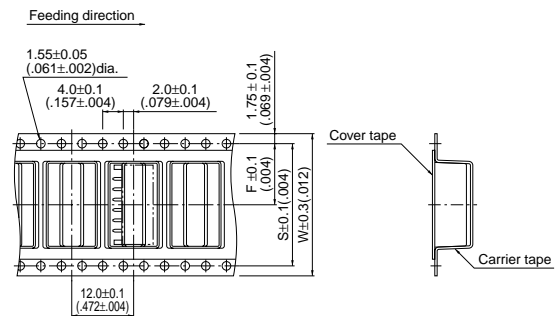

Circuits	Taping dimensions mm(in.)			Reel dimensions mm(in.)	Q'ty / reel	
	F	S	W			
Top entry type	2 to 3	7.5(.295)	—	16.0(.630)	17.5(.689)	1,000
	4 to 6	11.5(.453)	—	24.0(.945)	25.5(1.004)	1,000
	7 to 9	14.2(.559)	28.4(1.118)	32.0(1.260)	33.5(1.319)	1,000
	10 to 14	20.2(.795)	40.4(1.591)	44.0(1.732)	45.5(1.791)	1,000
	15 to 16	26.2(1.031)	52.4(2.063)	56.0(2.205)	57.5(2.264)	1,000
Side entry type	2 to 3	7.5(.295)	—	16.0(.630)	17.5(.689)	1,000
	4 to 6	11.5(.453)	—	24.0(.945)	25.5(1.004)	1,000
	7 to 9	14.2(.559)	28.4(1.118)	32.0(1.260)	33.5(1.319)	1,000
	10 to 14	20.2(.795)	40.4(1.591)	44.0(1.732)	45.5(1.791)	1,000
	15	26.2(1.031)	52.4(2.063)	56.0(2.205)	57.5(2.264)	1,000

Note:

1. Specifications conform to JIS C 0806. The tape width, connector loading recess square hole dimensions, etc. are determined by the number of circuits and external shape of the connector to be loaded.
2. Specifications are subject to change without prior notice.

SMT type PC board layout (viewed from component side) and Assembly layout

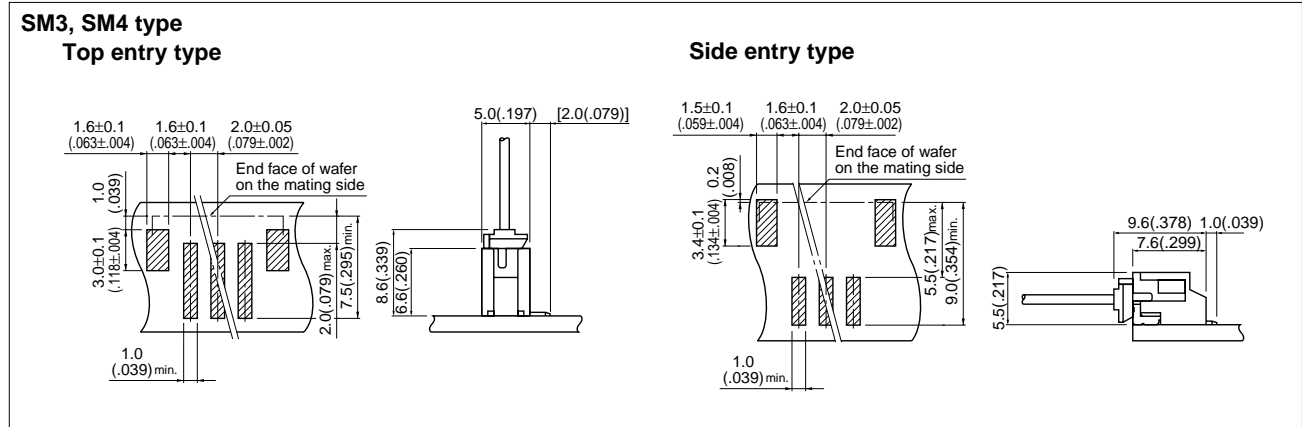

Note:

1. Tolerances are non-cumulative: $\pm 0.05\text{mm}$ ($\pm .002''$) for all centers.
2. The dimensions above should serve as a guideline. Contact JST for details.

Applicator for the semi-automatic press AP-K2N

Contact	Crimp applicator MKS-L(-10)		Compact crimp applicator MKS-LS		Strip-crimp applicator MKS-SC
	with safety cover	without safety cover	with safety cover	without safety cover	with safety cover
SPH-002T-P0.5S	APLMK SPH002-05S	APLNC SPH002-05S	APLMKLS SPH002-05S	APLLSNC SPH002-05S	APLSC SPH002-05S
SPH-004T-P0.5S	APLMK SPH004-05S	APLNC SPH004-05S	—	—	APLSC SPH004-05S
SPH-002T-P0.5L	APLMK SPH002-05L	APLNC SPH002-05L	APLMKLS SPH002-05L	APLLSNC SPH002-05L	APLSC SPH002-05L