

AEAT-6600-T16

10 to 16-Bit Programmable Angular Magnetic Encoder IC



Data Sheet

Description

The Avago AEAT-6600 angular magnetic encoder IC is a contactless magnetic rotary encoder for accurate angular measurement over a full turn of 360 degrees.

It is a system-on-chip, combining integrated Hall elements, analog front end and digital signal processing in a single device.

To measure the angle, only a simple two-pole magnet, rotating over the center of the chip, is required. The magnet may be placed above or below the IC.

The absolute angle measurement provides instant indication of the magnet's angular position with a resolution of $0.005^\circ = 65\,536$ positions per revolution. This digital data is available as a serial bit stream and as a PWM signal.

An internal voltage regulator allows the AEAT-6600 to operate at either 3.3 V or 5 V supplies.

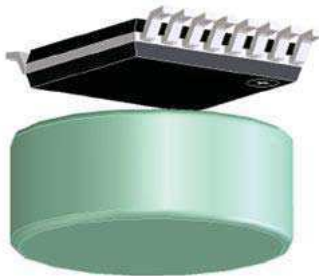

Figure 1. AEAT-6600 Series TSSOP-16 IC Package

Features

- 5 V or 3.3 V operation
- 3-wire or 2-wire SSI interface mode for absolute output
- Incremental ABI or UVW, and PWM output modes
- User-programmable zero position, direction & index pulse width
- Easy magnet alignment with magnetic field strength output and alignment mode
- Power-down mode to reduce current consumption
- TSSOP-16 IC package
- RoHS compliant

Specifications

- Absolute 10-bits to 16-bits resolution
- Incremental output resolutions 8 to 1024 CPR
- -40°C to 125°C operating temperature range

Applications

- 3-phase commutation for brushless DC motor
- Resolver and potentiometer replacement
- Industrial automation and robotics

NOTE: This product is not specifically designed or manufactured for use in any specific device. Customers are solely responsible for determining the suitability of this product for its intended application and solely liable for all loss, damage, expense or liability in connection with such use.

Definitions

Electrical Degree (°e): Resolution x 360 electrical degrees = 360 mechanical degrees.

Cycle (C): One cycle of the incremental signal is 360 mechanical degrees/Resolution and is equal to 360 electrical degrees (°e).

Cycle Error (ΔC): The difference between the actual cycle width and the ideal cycle width corresponding to a shaft angle displacement of 1/Resolution. The accumulated cycle error leads to position error.

Pulse Width (P): The number of electrical degrees that an output is high during one cycle, nominally 180°e or ½ a cycle.

Pulse Width Error (ΔP): The deviation in electrical degrees of the pulse width from its ideal value of 180°e.

State Width (S): The number of electrical degrees between a transition in the output of channel A and the neighboring transition in the output of channel B. There are 4 states per cycle, each nominally 90°e.

State Width Error (ΔS): The deviation in electrical degrees of each state width from its ideal value of 90°e.

Phase (ϕ): The number of electrical degrees between the center of the high state on channel A and the center of the high state on channel B.

Phase Error ($\Delta\phi$): The deviation in electrical degrees of the phase from its ideal value of 90°e.

Index Pulse Width (P₀): The number of electrical degrees that an index pulse is active within the cycle that coincides with the absolute zero position. The index pulse width is also expressed in terms of LSB (least significant bit) counts corresponding to the encoder resolution.

Integral non-linearity (INL): The maximum deviation between actual angular position and the position indicated by the encoder's output count, over one revolution. It is defined as the most positive linearity error +INL or the most negative linearity error -INL from the best fit line, whichever is larger.

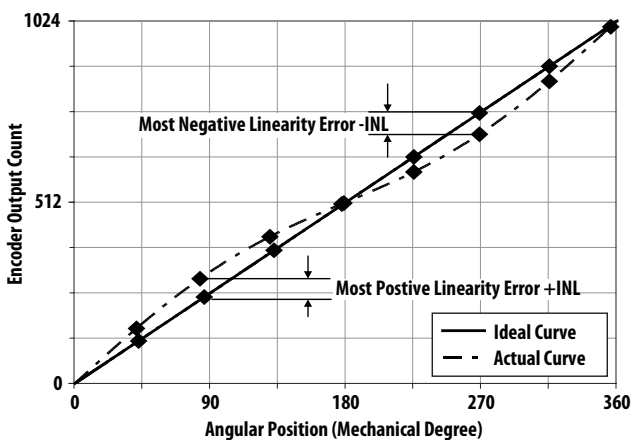

Figure 2. Integral Non-Linearity Example

Functional Description

The AEAT-6600 is manufactured with a CMOS standard process and uses a Hall technology for sensing the magnetic field distribution across the surface of the chip. The integrated Hall elements are placed around the center of the device and deliver a voltage representation of the magnetic field at the surface of the IC. The Digital Signal Processing (DSP) circuit converts the data from the Hall sensor into absolute angular position (DO/DI pin) as an absolute output or converted into digital output (A/U, B/V, I/W pins) by the incremental circuit.

The DSP circuit also provides digital information at the outputs MagHi and MagLo that indicate movements of the used magnet towards or away from the device's surface. A small low cost diametrically magnetized (two-pole) standard magnet provides the angular position information.

The AEAT-6600 senses the orientation of the magnetic field and calculates a 10 to 16-bit binary code. This code can be accessed via a Synchronous Serial Interface (SSI). In addition, an absolute angular representation is given by a Pulse Width Modulated signal at pin 8 (PWM). The AEAT-6600 is tolerant to magnet misalignment and magnetic stray fields due to local measurement technique and Hall sensor conditioning circuitry.

The OTP block provides an access to program to a specific resolution and output modes through a PROG pin (pin 13).

NOTE: For further information regarding the operating mode and application, please refer to the Application Note (AV02-2791EN). For programming tool and software application, please refer to the User Manual (AV02-2803EN).

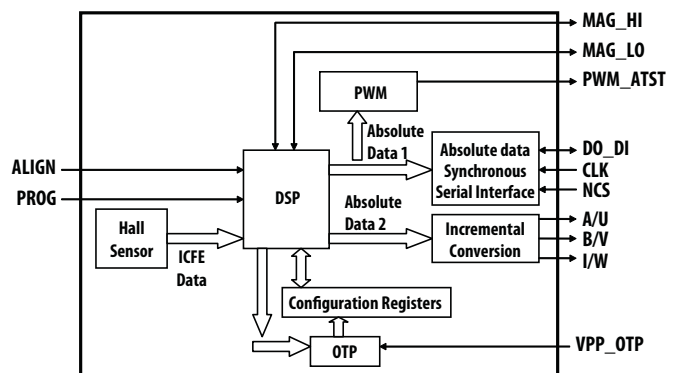

Figure 3. Polaris block diagram

Pin Assignments

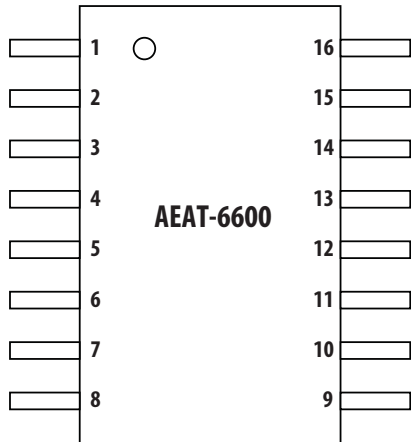

Figure 4. Pin Configuration TSSOP-16

Pin-out Description

Pin	Symbol	I/O Type	Description
1	A/U	Output	Incremental A output (ABI mode) U Commutation output (UVW mode)
2	B/V	Output	Incremental B output (ABI mode) V Commutation output (UVW mode)
3	I/W	Output	Index output (ABI mode) W Commutation output (UVW mode)
4	MAG_HI/OTP_ERR	Output	1 indicates magnetic field strength too high (Normal operation mode) 1 indicates OTP programming error (OTP program mode)
5	MAG_LO/OTP_PROG_STAT	Output	1 indicates magnetic field strength too low (Normal operation mode) 1 indicates OTP programming completed (OTP program mode)
6	GND	Ground	Supply Ground
7	ALIGN	Input (internal pull-down)	0: Normal operation mode 1: Alignment mode
8	PWM	Output	PWM output
9	VDD	Supply	5 V Supply input (connected to VDD_F for 3.3 V operation)
10	VDD_F	Supply	Filtered VDD
11	PWRDOWN	Input	0: Normal operation mode 1: Power-down mode
12	VPP	High Supply	6.5 V voltage supply for OTP programming. VDD at normal operation mode
13	PROG	Input (internal pull-down)	0: Normal operation mode 1: OTP programming mode
14	NCS	Input (internal pull-up)	SSI data strobe input
15	CLK	Input	SSI clock input
16	DO/DI	Input/Output (tri-state)	SSI data output (Absolute Output mode) Serial data input (OTP Program Mode)

Table 1. Absolute Maximum Ratings

Parameter	Symbol	Min.	Max.	Units	Notes
Storage Temperature	T _S	-40	125	°C	
DC supply voltage					
VDD pin	VDD	-0.3	7	Volts	
VPP pin	VPP	-0.3	7	Volts	
Input Voltage Range	V _{in}	-0.25	VDD+0.25	Volts	

CAUTION: Subjecting the product to stresses beyond those listed under this section may cause permanent damage to the devices. These are stress ratings only and do not imply that the devices will function beyond these ratings. Exposure to the extremes of these conditions for extended periods may affect product reliability.

Table 2. Recommended Operating Conditions

Parameter	Symbol	Min.	Typical	Max.	Units	Notes
Operating Ambient Temperature	T _A	-40	–	125	°C	
DC Supply Voltage to VDD pin						
5 V operation	VDD	4.5	5.0	5.5	Volts	VDD pin tied to VDD_F pin for 3.3 V operation.
3.3 V operation		3.0	3.3	3.6		
OTP Programming Voltage at VPP pin	VPP	6.3	6.5	6.7	Volts	VPP tied to VDD during normal operation mode
Incremental Output Frequency	f _{MAX}	–	–	512	kHz	Frequency = Velocity (rpm) x Resolution/60 Max RPM = 30000 rpm
Load Capacitance	C _L	–	–	50	pF	

Table 3. Electrical Characteristics

Condition: Electrical Characteristics over the Recommended Operating Conditions. Typical values specified at VDD = 5.0V and 25° C

Parameter	Symbol	Min.	Typ.	Max.	Units	Notes
Current Consumption						
Supply Current						
Normal Operation Mode	I _{DD}	–	17	21	mA	
Power-down Mode	I _{PD}	–	–	100	µA	
OTP Programming Current	I _{PP}	–	–	2	mA	VPP supply pin
Digital Outputs (DO)						
High Level Output Voltage	V _{OH}	VDD - 0.5	–	–	Volts	Normal Operation
Low Level Output Voltage	V _{OL}	–	–	GND + 0.4	Volts	
Output Leakage Current	I _{OZ}	-1	–	1	µA	
Power-up time	t _{pwrUp}	–	–	11	ms	
Absolute Output				11		
Incremental Output				11		
PWM Output				11		
Digital Inputs (DI)						
Input High Level	V _{IH}	0.7xVDD	–	–	Volts	
Input Low Level	V _{IL}	–	–	0.3xVDD	Volts	
Input Leakage Current	I _{LEAK}	-1	–	1	µA	CLK, DI pins
Pull-up low level input current	I _{IL}	–	–	30	µA	NCS pin
Pull-down high level input current	I _{IH}	–	–	30	µA	ALIGN, PROG

Table 4. Encoding Characteristics

Parameter	Symbol	Min.	Typ.	Max.	Units	Notes
Absolute Output						
Resolution	RES	10	–	16	Bit	10 and 16 Bits
Integral Non-Linearity (optimum)	INL _{nom}	–	±0.4	±0.9	Deg.	Maximum Error with respect to best line fit. Verified at nominal mechanical magnet placement. Tamb = 25° C
Integral Non-Linearity	INL	–	–	±1.9	Deg.	Best line fit = (Err _{max} – Err _{min})/2 Over displacement tolerance with 9mm diameter magnet, Tamb = -40 to +125° C
Output Sampling Rate	f _s	–	12	–	kHz	Refer to table5 for AEAT-6600-T16 Internal Sampling Time
Incremental Output (Channel ABI)						
Resolution	R _{INC}	8	–	1024	CPR	Options 8, 16, 32, 64, 128, 256, 512 or 1024 CPR
Index Pulse Width	P _O	90	–	360	°e	Options: 90, 180, 270 or 360 °e
Cycle Error	ΔC	–	7	60 80 100	°e	8, 16, 32, 64, 128 CPR 256 CPR 512, 1024 CPR
Pulse Width Error	ΔP	–	5	40 50 60	°e	8, 16, 32, 64, 128 CPR 256 CPR 512, 1024 CPR
State Width Error	ΔS	–	3	40 50 60	°e	8, 16, 32, 64, 128 CPR 256 CPR 512, 1024 CPR
Phase Error	Δφ	–	2	20 25 30	°e	8, 16, 32, 64, 128 CPR 256 CPR 512, 1024 CPR
Index Pulse Width Error	P _o	60 150 240 330	90 180 270 360	120 210 300 390	°e	Index Pulse Width Gated 90°e Index Pulse Width Gated 180°e Index Pulse Width Gated 270°e Index Pulse Width Gated 360°e
Velocity		1	–	30,000	RPM	
Note: Encoding Characteristics above are based on 12-bits resolution.						
Commutation Characteristic (Channel U,V,W)						
Commutation Format						Four phase 1,2,4 or 8 pole pairs
Commutation Accuracy	ΔUVW	-2	–	+2	°mechanical	
Velocity	1, 2, 4, 8 Poles	1	–	30,000	RPM	
PWM Output						
PWM frequency 10 bits	f _{PWM}	3040	3800	4560	Hz	
Minimum pulse width 10 bits	PW _{MIN}	0.8	1	1.2	μs	
Maximum pulse width 10 bits	PW _{MAX}	210	263	315	μs	
Note: Encoding Characteristics over Recommended Operating Range unless otherwise specified.						

Table 5. Encoding Timing Characteristics

Parameter	Symbol	Min.	Typ.	Max.	Units	Notes
Absolute Output						
System refresh time						
10-bit	$t_{Refresh}$	–	–	111	μs	First SSI Absolute Output upon Power-Up
12-bit		–	–	111	μs	
14-bit		–	–	111	μs	
16-bit		–	–	111	μs	
System reaction time (Fast Mode)						
10-bit	t_{Fast}	–	–	111	μs	No averaging reaction time
12-bit		–	–	111	μs	
14-bit		–	–	111	μs	
16-bit		–	–	111	μs	
System reaction time (Slow Mode)						
10-bit	t_{Slow}	–	–	111	μs	Averaging reaction time
12-bit		–	–	442	μs	
14-bit		–	–	7.1	ms	
16-bit		–	–	113	ms	
Incremental Output (ABI & UVW)						
System reaction time (Fast Mode)	$t_{Inc.}$	–	–	720	μs	(for 400 to 1800rpm)
		–	–	310	μs	(for 1800rpm and above)

Notes:

The $t_{Refresh}$, t_{Fast} , t_{Slow} , $t_{Inc.}$ are AEAT-6600-T16 internal sampling time.

Slow Mode is not recommended for Incremental Output. Contact factory for Slow Mode Application on Incremental Output

Table 6. Recommended Magnetic Input Specifications

Parameter	Symbol	Min.	Typ.	Max.	Units	Notes
Diameter	d		9		mm	Recommended magnet: Cylindrical magnet, diametrically magnetized & 1 pole pair.
Thickness	t		3		mm	
Magnet radial magnetic flux density	B_radial	188	198	208	mT	Measured at 1.3 mm away from center of magnet radial surface. Magnet validation purpose
Magnet plane magnetic flux density	B_plane	106	112	118	mT	B_plane at 1.3 mm from magnet flat surface. Hall sensor required plane components magnetic field
Magnetization vector tilt	Mag_Vec			+/- 5		Magnet magnetization vector tilt
Magnet displacement radius	R_m			0.1	mm	Displacement between magnet axis to rotational axis
Hall sensor displacement radius	R_s			0.5	mm	Displacement between hall sensor axis to rotational axis
Recommended magnet material and temperature drift			-0.11		%/°C	NdFeB (Neodymium Iron Boron), grade N35SH

DISCLAIMER: The above information is based on the spec provided by the supplier of the magnet used for product characterization. The supplier of the magnet is solely responsible for the specification and performance of the magnet used.

Magnet and IC Package Placement

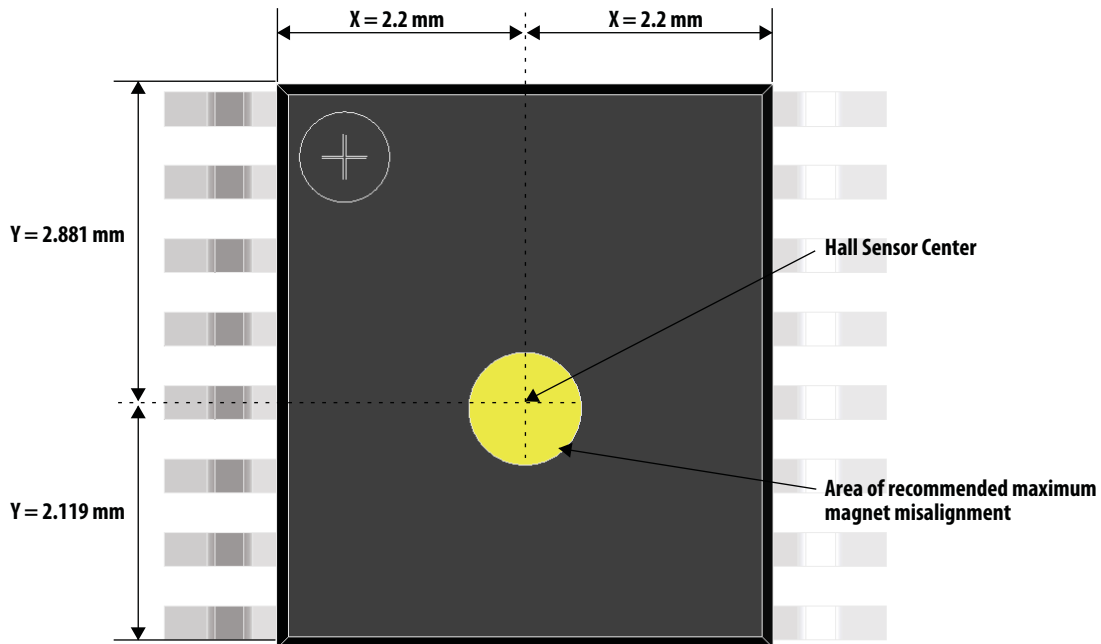

The magnet's centre axis should be aligned within a displacement radius of 0.5mm from defined hall sensor center.

Figure 5. Magnet and IC Package Placement

Defined Chip Sensor Center and Magnet Displacement Radius

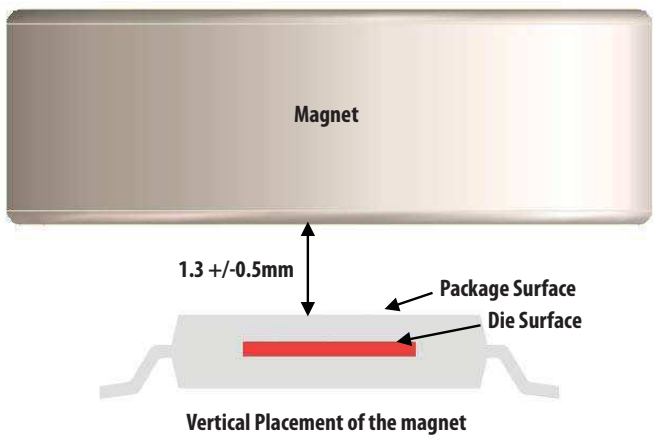

Figure 6. Defined Chip Sensor Center and Magnet Displacement Radius

Table 7. SSI Timing Characteristics

Parameter	Sym	Min.	Typ.	Max.	Units	Notes
fclk		-	-	1000	kHz	
tCLK FE		-	-	500	ns	minimum time required for encoder to freeze data and prepare shift registers before receiving the first rising edge to prompt the MSB
tDO active		-	100	-	ns	
tDO valid		-	50	-	ns	
tCSn		-	500	-	ns	
tDO Tristate		-	100	-	ns	
tDELAY		-	500	-	ns	minimum time required for encoder to freeze data and prepare shift registers before receiving the first rising edge to prompt the MSB.
tRefresh		20	-	-	μs	required waiting time to refresh position data between subsequent position reads
tTIMEOUT		-	-	20	μs	every falling edge of the clock
tWAIT		-	-	10	μs	max time to hold DO to low

Note: SSI Timing Characteristics over Recommended Operating Range unless otherwise specified.

SSI Timing Diagram

3-Wire and 2-Wire SSI Mode

SSI 3-wired

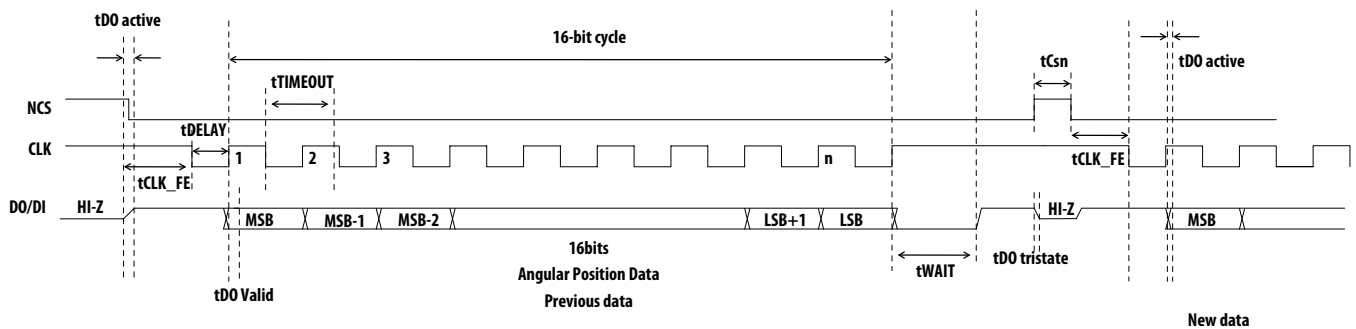

SSI 2-wired

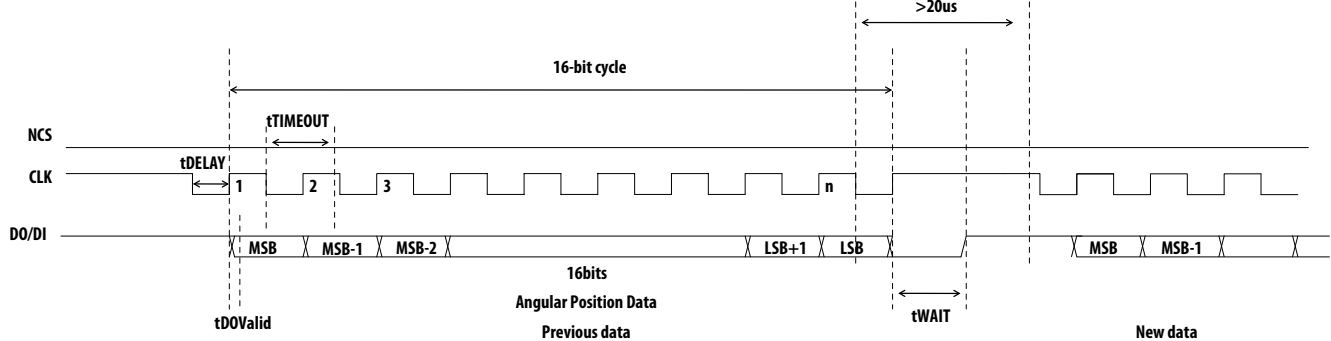

Figure 7. SSI Timing Diagram

Generally, SSI protocol is using a master/slave relationship, in which the master initiates the data frame. CLK is generated by the master (controller) and input to all slaves. In AEAT-6600-T16, position data is continually updated by the encoder (AEAT-6600-T16) and made available to the shift register.

Incremental ABI Output

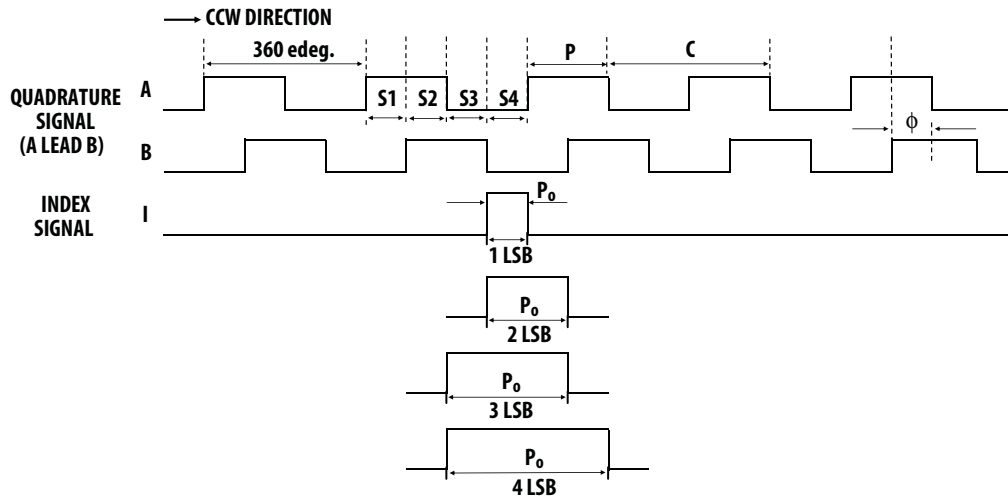

Figure 8. Incremental ABI signals

With Incremental ABI output enable, AEAT-6600-T16 is able to provide position data and direction data with the resolution 8 to 1024 CPR. Index signal marks absolute angular position and typically occurs once per revolution, with the options 90, 180, 270, 360. Lastly, Index signal will clear the counter after each full rotation.

UVW Commutation Output

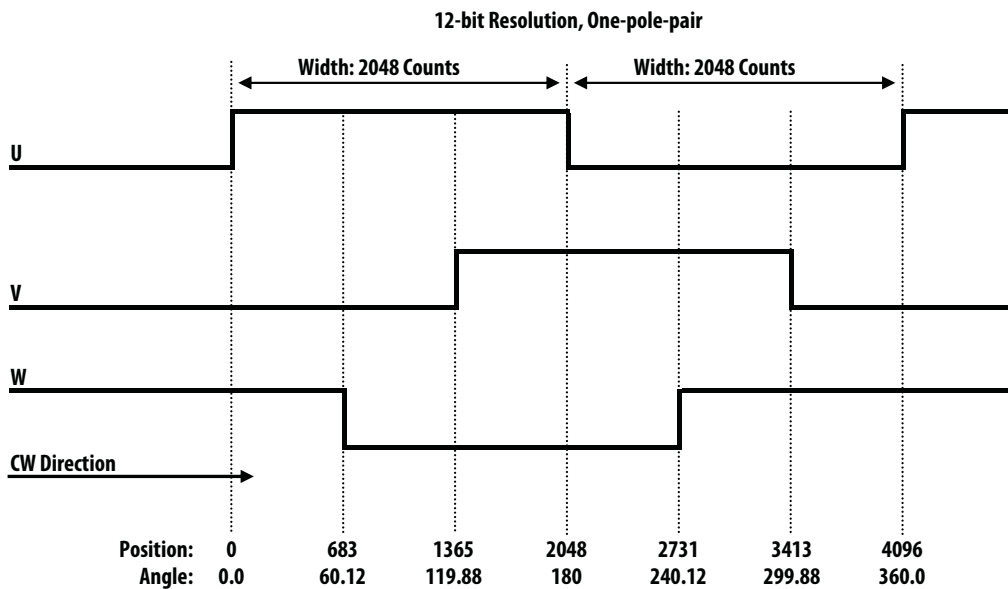

Figure 9. UVW commutation signals – 12-bit resolution, one-pole-pair

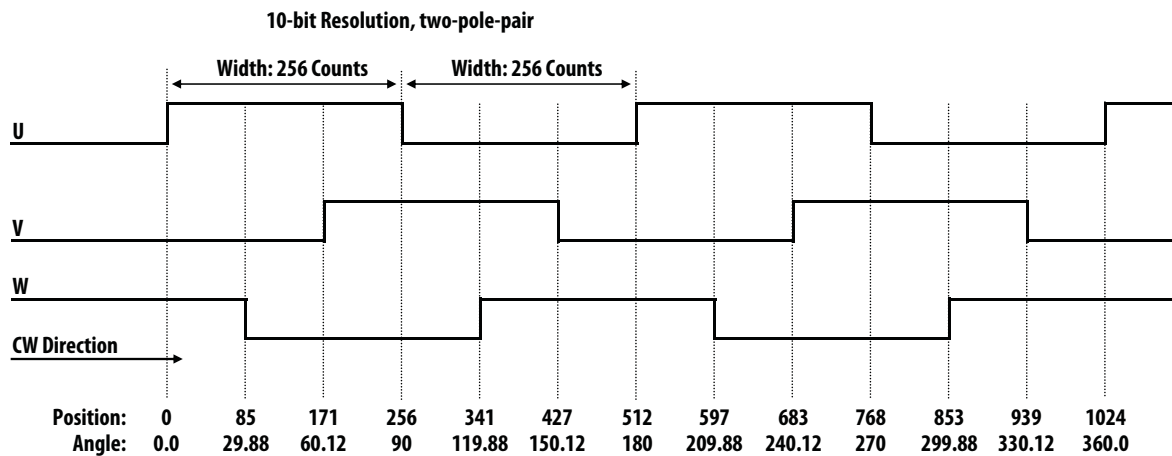

Figure 10. UVW commutation signals – 10-bit resolution, two-pole-pairs

In this option, three channel integrated commutation output (U, V, W) will serve the purpose to emulate Hall sensor feedback. With this, AEAT-6600-T16 is able to align commutation encoder signal to the correct phase of the motor. Generally, the more the pole-pairs the finer commutation steps (AEAT-6600 up to 1, 2, 4, 8 Pole-pairs)

PWM Output

$$\text{Position} = \frac{t_{on} \cdot 1025}{(t_{on} + t_{off})} - 1$$

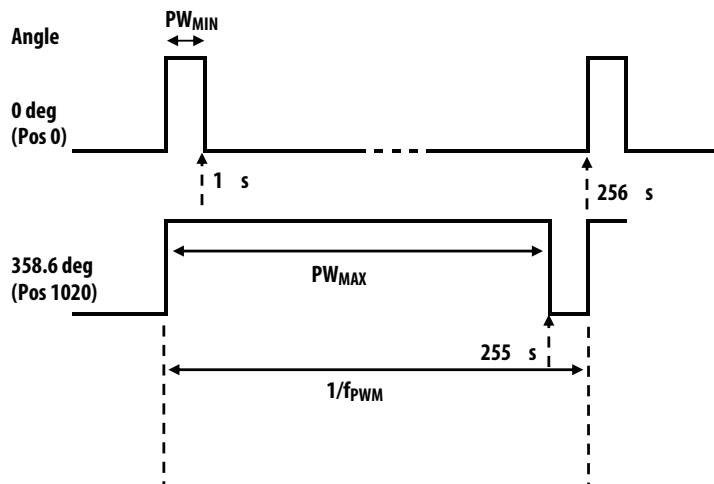
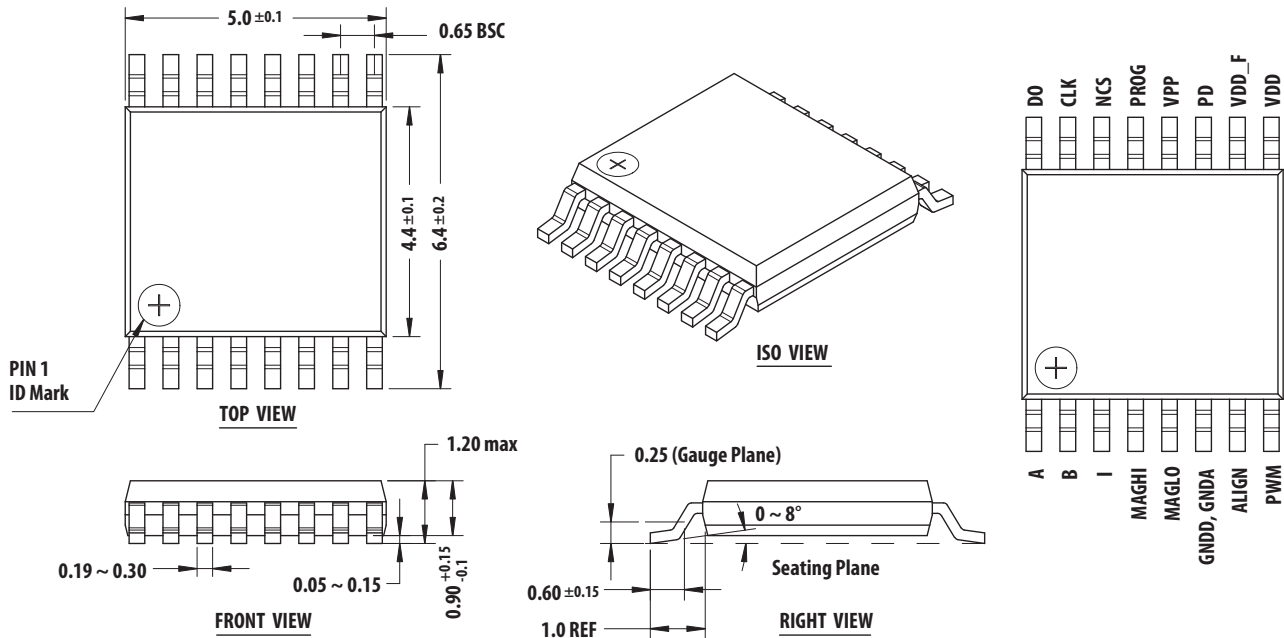

Figure 11. PWM signals – 12 bit resolution

PWM output is considered as another Absolute output besides SSI. In PWM mode, duty cycle is proportional to the measured angle. For full rotation angle, 360 degree is equivalent to position 0 to 1023. For instance, an angle position of 358.6° will generate a pulse width $t_{on} = 255 \mu s$ and a pause t_{off} of $1 \mu s$ resulting in Position = 1020 after the calculation: $255 \cdot 1025 / (255 + 1) - 1 = 1020$

Package Drawings



All dimensions unit: mm

Figure 12. AEAT-6600, 16-Lead TSSOP dimensions

Ordering Information

AEAT-6600-T16

For product information and a complete list of distributors, please go to our web site: www.avagotech.com

Avago, Avago Technologies, and the A logo are trademarks of Avago Technologies in the United States and other countries. Data subject to change. Copyright © 2005-2012 Avago Technologies. All rights reserved. AV02-2792EN - June 25, 2012

Avago
TECHNOLOGIES