

# HCMOS SURFACE-MOUNT CRYSTAL CLOCK OSCILLATOR



2.0 x 1.6 x 0.7 mm

**ASA SERIES**

Moisture Sensitivity Level (MSL) – This product is Hermetically Sealed and not Moisture Sensitive - MSL = N/A: Not Applicable



**RoHS**  
Compliant

## FEATURES:

- Ultra miniature package, 2.0 x 1.6 x 0.7mm
- Tri-state function
- Suitable for high density SMT
- Suitable for RoHS compliant reflow process
- Seam sealed package assures high reliability

## APPLICATIONS:

- CCD clock for VTR camera
- Computers and peripherals
- Portable electronics
- Mobile communication, PDA

## STANDARD SPECIFICATIONS:

Parameters		Minimum	Typical	Maximum	Units	Notes		
Frequency Range		1.0	----	80	MHz			
Operating Temperature		-10	----	+60	°C	See options		
Storage Temperature		-40	----	+85	°C			
Overall Frequency Stability*		-50	----	+50	ppm	See options		
Supply Voltage (Vdd)		2.97	3.3	3.66	V	Standard		
		2.25	2.5	2.75		Option 1 (CMOS)		
		1.62	1.8	1.98		Option 2 (CMOS)		
Supply Current (I <sub>dd</sub> )	Vdd = 3.3 V	----	2.0	5.0	mA	1MHz ≤ F ≤ 20 MHz		
		----	4.0	10.0		20 MHz < F ≤ 50 MHz		
		----	7.0	15.0		50 MHz < F ≤ 80 MHz		
	Vdd = 2.5 V	----	2.0	5.0		1MHz ≤ F ≤ 20 MHz		
		----	3.0	10.0		20 MHz < F ≤ 50 MHz		
		----	5.0	10.0		50 MHz < F ≤ 80 MHz		
	Vdd = 1.8 V	----	1.5	5.0		1MHz ≤ F ≤ 20 MHz		
		----	2.5	5.0		20 MHz < F ≤ 50 MHz		
		----	4.0	10.0		50 MHz < F ≤ 80 MHz		
	Output Load		----	----		15	pF	
			----	----		2	TTL	
	Output Voltage	V <sub>OH</sub>	0.9*Vdd	----		----	V	CMOS
V <sub>OL</sub>		----	----	0.1*Vdd	CMOS			
V <sub>OH</sub>		2.4	----	----	TTL			
V <sub>OL</sub>		----	----	0.4	TTL			
Tri-state function		"1" (VIH ≥ 0.7*Vdd) : Oscillation "0" (VIH < 0.3*Vdd) : Hi Z				Pin 1 must be pulled "high" for oscillation		
Aging		-3.0	----	+3.0	ppm	@+25°C First year		
Symmetry @1/2Vdd		40	50	60	%	Standard		
		45	50	55		Option S		
Start-up Time				10.0	ms			
Rise/Fall Time (Tr/Tf)				10.0	ns			

\*Overall frequency stability includes initial frequency tolerance @+25°C and stability over the operating temperature.

## OPTIONS AND PART IDENTIFICATION:

(Left blank if standard)

ASA  -  MHz -  -  -  -

Supply Voltage
Blank: 3.3V±10%
1: 2.5 V±10%
2: 1.8 V±10%

Packaging
Blank: Bulk
T: Tape & Reel (1kpcs)
T3: Tape & Reel (3kpcs)

Frequency in MHz
Please specify the frequency in MHz. e.g. 14.31818MHz

Operating Temp.
Blank: -10°C ~ +60°C
E: -20°C ~ +70°C
L: -40°C ~ +85°C

Overall Freq. Stability
Blank: ±50ppm
R**: ±25ppm
K***: ±30 ppm

Symmetry
Blank: 40/60% @1/2Vdd
S: 45/55% @1/2Vdd

\*\*Available for -10 to +60°C only

\*\*\*Available for -10 to +60°C, option E only

Contact Abracon for tighter frequency stability options

ABRACON IS  
ISO9001:2008  
CERTIFIED



**ABRACON**  
CORPORATION

Visit [www.abracon.com](http://www.abracon.com) for Terms & Conditions of Sale **Revised: 03.12.12**

30332 Esperanza, Rancho Santa Margarita, California 92688

tel 949-546-8000 | fax 949-546-8001 | [www.abracon.com](http://www.abracon.com)

# HCMOS SURFACE-MOUNT CRYSTAL CLOCK OSCILLATOR



ASA

2.0 x 1.6 x 0.7mm

ASA SERIES



RoHS  
Compliant

## OUTLINE DRAWING:

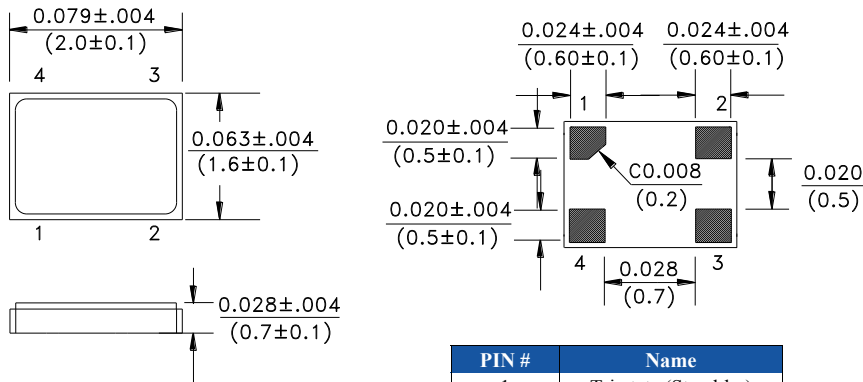

### Recommended land pattern

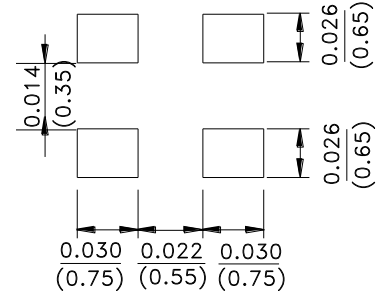

Dimensions: inches (mm)

PIN #	Name
1	Tri-state (Stand-by)
2	GND
3	Output
4	Vdd

## TAPE & REEL:

T= Tape and reel (1,000pcs/reel)  
T3= Tape and reel (3,000pcs/reel)

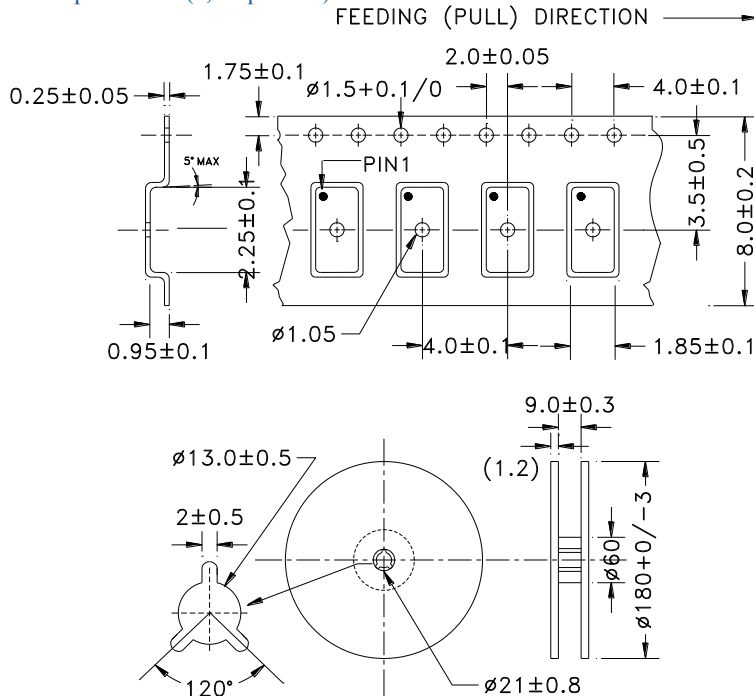

Dimensions: mm

## REFLOW PROFILE:

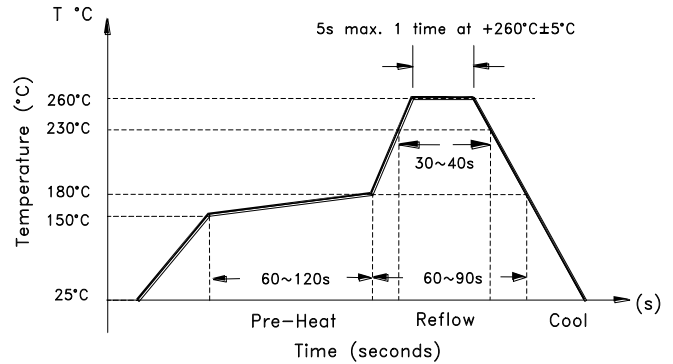

Need a test socket for the ASA Series? To view compatible **PRECISION TEST & BURN-IN SOCKETS** for these parts, [click here](#).

**ATTENTION:** Abracon Corporation's products are COTS – Commercial-Off-The-Shelf products; suitable for Commercial, Industrial and, where designated, Automotive Applications. Abracon's products are not specifically designed for Military, Aviation, Aerospace, Life-dependant Medical applications or any application requiring high reliability where component failure could result in loss of life and/or property. For applications requiring high reliability and/or presenting an extreme operating environment, written consent and authorization from Abracon Corporation is required. Please contact Abracon Corporation for more information.

ABRACON IS  
ISO9001:2008  
CERTIFIED



ABRACON  
CORPORATION

Visit [www.abracon.com](http://www.abracon.com) for Terms & Conditions of Sale **Revised: 03.12.12**

30332 Esperanza, Rancho Santa Margarita, California 92688

tel 949-546-8000 | fax 949-546-8001 | [www.abracon.com](http://www.abracon.com)