

Micro i[®] Chip Inductors

RF INDUCTORS

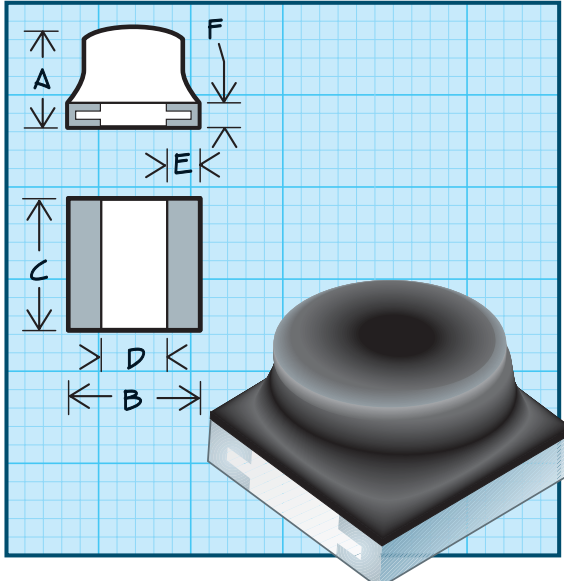

Military Specifications

Series 105 MIL-PRF-83446 (Reference)
 Series 108 MIL-PRF-83446/8 (Reference)

Physical Parameters for Series 105

	Inches	Millimeters
A	0.075 Max.	1.91 Max.
B	0.100 ± 0.010	2.54 ± .25
C	0.100 ± 0.010	2.54 ± .25
D	0.050 Min.	1.27 Min.
E	0.015 Min. (Typ.)	0.38 Min. (Typ.)
F	0.020 Max. (Typ.)	0.51 Max. (Typ.)

Physical Parameters for Series 108

	Inches	Millimeters
A	0.070 Max.	1.78 Max.
B	0.100 ± 0.010	2.54 ± .254
C	0.100 ± 0.010	2.54 ± .254
D	0.050 Min.	1.27 Min.
E	0.025 ± 0.005 (Typ.)	0.635 ± 0.13 (Typ.)
F	0.020 Max. (Typ.)	0.51 Max. (Typ.)

Weight Max. (Grams) 0.05

Current Rating at 90°C Ambient 35°C Rise

Operating Temperature Range -55°C to +125°C

Maximum Power Dissipation at 90°C 0.135 Watts

Mechanical Configuration Units are epoxy encapsulated. Contact areas for reflow soldering are gold plated per MIL-G-45204 Type-1-Grade A. Internal connections are thermal compression bonded.

Packaging Tape & reel (8 mm): 7" reel, 2000 pieces max.; 13"-reel, 8000 pieces max.

Made in the U.S.A.

DASH NUMBER
 MIL DASH # (Reference)
 INDUCTANCE (µH)
 TOLERANCE
 Q MINIMUM
 TEST FREQUENCY (MHz)
 SRF MINIMUM (MHz)
 DC RESISTANCE MAXIMUM (OHMS)
 CURRENT RATING MAX. (mA)

SERIES 105 IRON CORE

-121M	0.12	± 20%	40	25.0	500	0.14	830
-151M	0.15	± 20%	40	25.0	440	0.16	775
-181M	0.18	± 20%	40	25.0	405	0.19	710
-221K	0.22	± 10%	40	25.0	360	0.21	675
-271K	0.27	± 10%	40	25.0	330	0.23	650
-331K	0.33	± 10%	35	25.0	280	0.25	620
-391K	0.39	± 10%	35	25.0	185	0.28	585
-471K	0.47	± 10%	35	25.0	178	0.31	555
-561K	0.56	± 10%	35	25.0	163	0.45	460
-681K	0.68	± 10%	35	25.0	160	0.62	395
-821K	0.82	± 10%	30	25.0	155	0.65	385
-102K	1.0	± 10%	30	25.0	130	0.73	360
-122K	1.2	± 10%	25	7.9	115	1.0	310
-152K	1.5	± 10%	25	7.9	100	1.2	280
-182K	1.8	± 10%	25	7.9	90	1.5	250
-222K	2.2	± 10%	25	7.9	75	1.7	235
-272K	2.7	± 10%	25	7.9	68	2.0	220
-332K	3.3	± 10%	25	7.9	62	2.2	210
-392K	3.9	± 10%	25	7.9	57	2.8	185
-472K	4.7	± 10%	30	7.9	52	3.1	175
-562K	5.6	± 10%	30	7.9	47	3.3	170
-682K	6.8	± 10%	30	7.9	42	3.8	160
-822K	8.2	± 10%	30	7.9	40	5.0	135
-103K	10.0	± 10%	30	7.9	38	5.6	130

M83446/8- (Reference)

SERIES 108 IRON CORE

-123K	87	12.0	± 10%	36	2.5	26.0	4.0	79
-153K	88	15.0	± 10%	32	2.5	24.0	4.2	79
-183K	89	18.0	± 10%	32	2.5	21.0	4.4	75
-223K	90	22.0	± 10%	32	2.5	19.0	7.5	57
-273K	91	27.0	± 10%	32	2.5	14.0	8.0	55
-333K	92	33.0	± 10%	30	2.5	12.0	13.0	45
-393K	93	39.0	± 10%	30	2.5	10.0	17.0	38
-473K	94	47.0	± 10%	30	2.5	9.0	19.0	36
-563K	95	56.0	± 10%	30	2.5	8.5	23.0	33
-683K	96	68.0	± 10%	30	2.5	8.2	25.0	32
-823K	97	82.0	± 10%	30	2.5	8.0	28.0	30
-104K	98	100.0	± 10%	30	2.5	7.0	31.0	28

Optional Tolerances: J = 5% H = 3% G = 2% F = 1%

***Complete part # must include series # PLUS the dash #**

For further surface finish information, refer to TECHNICAL section of this catalog.

Termination Finish Options (Part # Code)

Gold over Nickel (Standard): As shown.
 Tin/Lead over Nickel: Add suffix "S" to part # (e.g., 105-102KS or 108-473KS).
 Mil type "A:" Gold over Nickel (Standard)
 Mil type "B" or "F:" Tin/Lead (solder) over Nickel.
 RoHS type: Order 105R - XXXKS or 108R - XXXKS

Notes 1) Designed specifically for reflow soldering and other high temperature processes with metalized edges to exhibit solder fillet. **2)** Self Resonant Frequency (SRF) Values above 185-MHz for Series 105 are calculated (reference only).