

# Series 0603R 0603

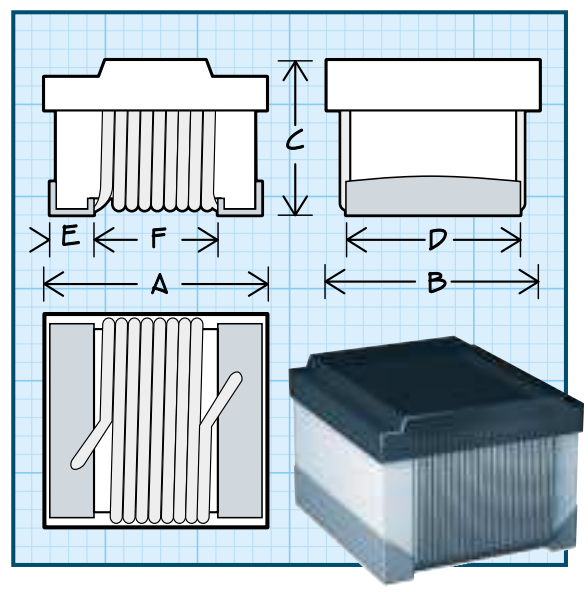

## Open Construction Wirewound Surface Mount Inductors



### Physical Parameters

	Inches	Millimeters
A	0.071 Max.	1.80 Max.
B	0.045 Max.	1.14 Max.
C	0.040 Max.	1.02 Max.
D	0.030 (Ref. only)	0.76 (Ref. only)
E	0.018 (Ref. only)	0.44 (Ref. only)
F	0.040 (Ref. only)	1.03 (Ref. only)
G	0.040	1.03
H	0.025	0.64
I	0.025	0.64

**Operating Temperature Range** -40°C to +125°C

**Inductance and Q** tested on HP4291A using HP16193A test fixture, or equivalent

**Packaging** Tape & reel (8mm): 7" reel, 4000 pieces max.

### LAND PATTERN DIMENSIONS

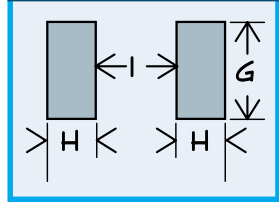

DASH NUMBER*	INDUCTANCE (nH) ±10%	Q MINIMUM	INDUCTANCE & Q TEST FREQUENCY (MHz)	SRF MINIMUM (MHz)	DC RESISTANCE MAXIMUM (Ohms)	CURRENT RATING MAXIMUM (mA)
SERIES 0603 CERAMIC CORE						
-1N6K	1.6	16	250	6000	0.040	700
-1N8K	1.8	16	250	6000	0.045	700
-3N3K	3.3	22	250	6000	0.080	700
-3N6K	3.6	22	250	5800	0.063	700
-3N9K	3.9	22	250	6000	0.080	700
-4N3K	4.3	22	250	5800	0.063	700
-4N7K	4.7	25	250	5800	0.120	700
-5N1K	5.1	20	250	5800	0.160	700
-5N6K	5.6	20	250	5800	0.170	700
-6N8K	6.8	27	250	5800	0.110	700
-7N5K	7.5	27	250	4800	0.110	700
-8N2K	8.2	27	250	4800	0.110	700
-8N7K	8.7	27	250	4800	0.110	700
-9N5K	9.5	27	250	4800	0.130	700
-10NK	10	31	250	4800	0.130	700
-11NK	11	31	250	4000	0.086	700
-12NK	12	35	250	4000	0.130	700
-15NK	15	35	250	4000	0.170	700
-16NK	16	35	250	3300	0.110	700
-18NK	18	35	250	3100	0.170	700
-22NK	22	38	250	3000	0.190	700
-24NK	24	38	250	2800	0.130	700
-27NK	27	40	250	2800	0.220	600
-30NK	30	40	250	2800	0.150	600
-33NK	33	40	250	2300	0.220	600
-36NK	36	40	250	2300	0.250	600
-39NK	39	40	250	2200	0.250	600
-43NK	43	38	200	2000	0.280	600
-47NK	47	38	200	2000	0.280	600
-56NK	56	38	200	1900	0.310	600
-68NK	68	37	200	1700	0.340	600
-72NK	72	34	150	1700	0.490	400
-82NK	82	34	150	1700	0.540	400
-101K	100	34	150	1400	0.580	400
-111K	110	32	150	1350	0.610	300
-121K	120	32	150	1300	0.650	300
-151K	150	32	100	1300	0.950	280
-181K	180	25	100	1200	1.400	250
-221K	220	25	100	1200	1.600	250
-271K	270	25	100	900	2.100	200
-331K	330	25	100	900	3.800	100
-391K	390	25	100	900	4.350	100

Optional Tolerances: J = 5% G=2%  
(1.6nH & 1.8nH Min. Tolerance is ±5%)

\*Complete part # must include series # PLUS the dash #

For further surface finish information, refer to TECHNICAL section of this catalog.

RF INDUCTORS