

## Descriptions

The AP432 and AP432A are 3-terminal adjustable precision shunt regulators with guaranteed stable temperature over the applicable extended commercial temperature range. The output voltage may be set at any level greater than 1.24V ( $V_{REF}$ ) up to 20V merely by selecting two external resistors that act as a voltage divider network. These devices have a typical output impedance of 0.2Ω. Active output circuitry provides very sharp turn-on characteristics, making these devices excellent improved replacements for Zener diodes in many applications.

The precise +/- 1% reference voltage tolerance of the AP432/AP432A make it possible in many applications to avoid the use of a variable resistor, consequently saving cost and eliminating drift and reliability problems associated with it.

## Features

- Precision reference voltage
  - AP432 : 1.24V ± 1%
  - AP432A : 1.24V ± 0.5%
- Sink current capability: 200mA
- Minimum cathode current for regulation: 150μA
- Equivalent full-range temp coefficient: 30 ppm/°C
- Fast turn-on response
- Low dynamic output impedance: 0.2Ω
- Programmable output voltage to 20V
- Low output noise
- Lead Free packages: SOT25, SC59, SC59R, SOT89-3L and TO92-3L
- SOT23, SOT23R, SOT25, SC59, SC59R, SOP-8L, SOT89-3L and TO92-3L: Available in "Green" Molding Compound (No Br, Sb)
- Lead Free Finish/ RoHS Compliant (Note 1)

Notes: 1. EU Directive 2002/95/EC (RoHS). All applicable RoHS exemptions applied. Please visit our website at [http://www.diodes.com/products/lead\\_free.html](http://www.diodes.com/products/lead_free.html).

## Typical Application Circuit

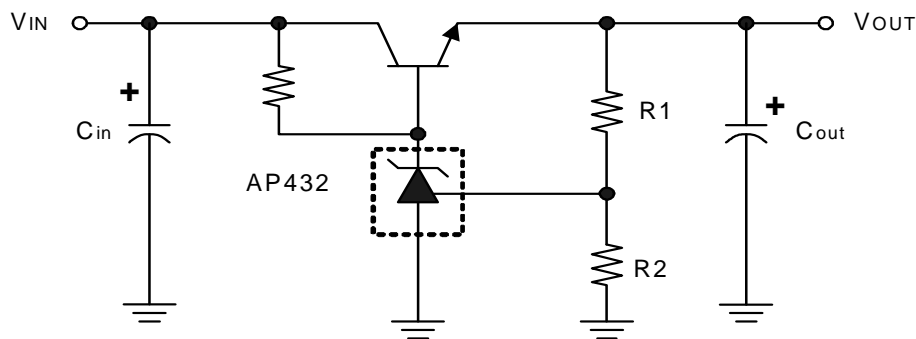

$$V_{OUT} = (1 + R1/R2)V_{REF}$$

Precision Regulator

**Pin Assignments**

(1) SOT25

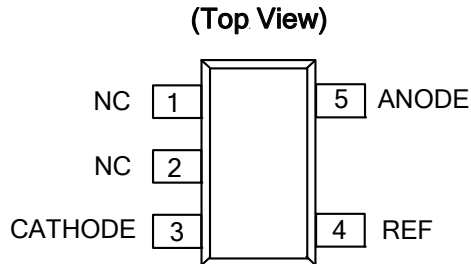

(2) SOP-8L

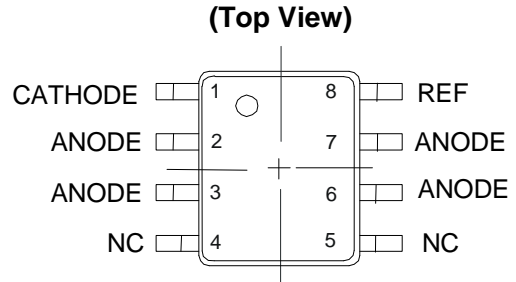

(3) SC59

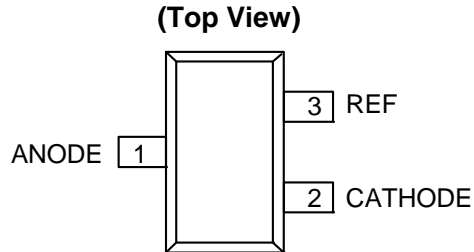

(4) SC59R

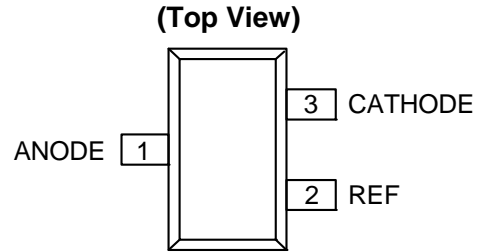

(5) SOT23

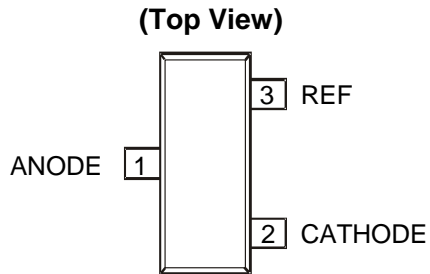

(6) SOT23R

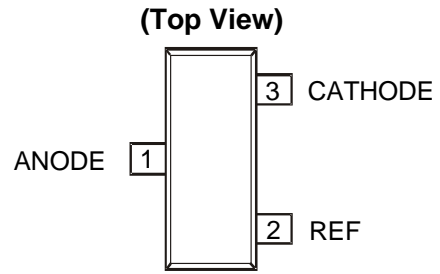

(7) SOT89-3L

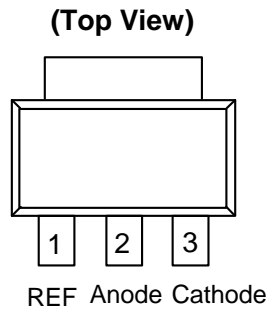

(8) TO92-3L

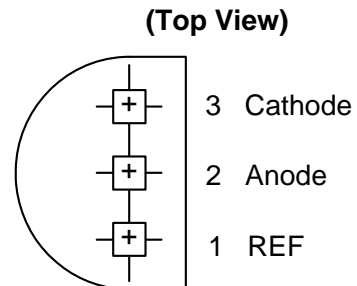

**Functional Block Diagram**

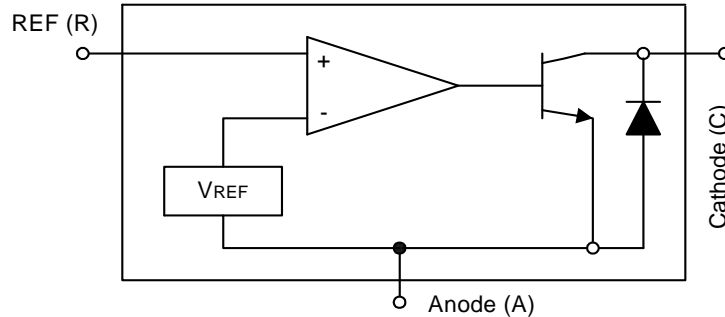

**Symbol**

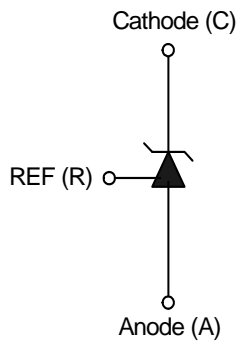

**Absolute Maximum Ratings**

Symbol	Parameter	Rating	Unit	
V <sub>CV</sub>	Cathode Voltage	+20	V	
I <sub>CC</sub>	Continuous Cathode Current	-10 to +250	mA	
I <sub>REF</sub>	Reference Input Current	10	mA	
T <sub>OP</sub>	Operating Temperature	-20 to +85	°C	
T <sub>ST</sub>	Storage Temperature	-65 to +150	°C	
P <sub>D</sub>	Power Dissipation (Notes 2, 3)	SOT23(R)	400	mW
		SOT25	550	mW
		SC59(R)	400	mW
		SOP-8L	600	mW
		SOT89-3L	800	mW
		TO92-3L	780	mW

Notes: 2. T<sub>J</sub>, max =150° C.  
3. Ratings apply to ambient temperature at 25°C.

**Electrical Characteristics (T<sub>A</sub> = 25°C, V<sup>+</sup> = +5.0V, unless otherwise stated)**

Symbol	Parameter	Test Conditions		Min	Typ.	Max	Unit
V <sub>REF</sub>	Reference voltage	V <sub>KA</sub> = V <sub>REF</sub> , I <sub>KA</sub> = 10mA (Fig.1)	AP432 AP432A	1.227 1.233	1.24	1.252 1.246	V
V <sub>REF</sub>	Deviation of Reference input voltage over temperature (Note 4)	V <sub>KA</sub> = V <sub>REF</sub> , I <sub>KA</sub> = 10mA, T <sub>a</sub> = Full range (Fig.1)		—	3.0	20	mV
$\frac{\Delta V_{REF}}{\Delta V_{KA}}$	Ratio of the change in Reference voltage to the change in Cathode voltage	I <sub>KA</sub> = 10mA (Fig. 2)	V <sub>KA</sub> = 20~ V <sub>REF</sub>	—	-1.4	-2.0	mV/V
I <sub>REF</sub>	Reference input current	R1 = 10KΩ, R2 = ∞ I <sub>KA</sub> = 10mA (Fig. 2)		—	1.4	3.5	μA
αI <sub>REF</sub>	Deviation of Reference input current over temperature	R1 = 10KΩ, R2 = ∞ I <sub>KA</sub> = 10mA T <sub>a</sub> = Full range (Fig. 2)		—	0.4	1.2	μA
I <sub>KA(MIN)</sub>	Minimum Cathode current for regulation	V <sub>KA</sub> = V <sub>REF</sub> (Fig.1)		—	0.15	0.3	mA
I <sub>KA(OFF)</sub>	Off-state current	V <sub>KA</sub> = 36V, V <sub>REF</sub> = 0V (Fig. 3)		—	0.1	1.0	μA
Z <sub>KA</sub>	Dynamic output impedance (Note 5)	V <sub>KA</sub> = V <sub>REF</sub> V <sub>KA</sub> = V <sub>REF</sub> ΔI <sub>KA</sub> = 0.1mA ~ 15mA Frequency ≤ 1KHz (Fig.1)		—	0.2	0.5	Ω

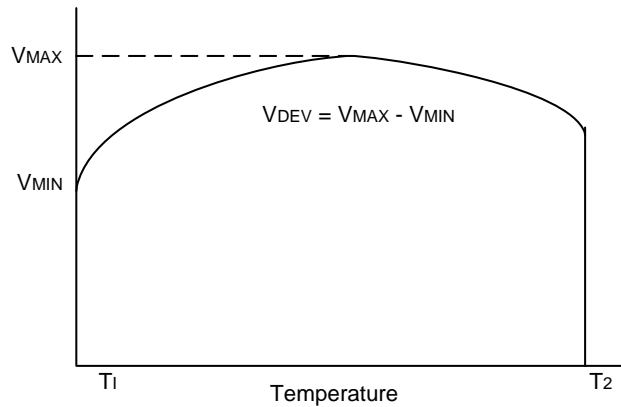

Notes: 4. Deviation of reference input voltage, V<sub>DEV</sub>, is defined as the maximum variation of the reference over the full temperature range. The average temperature coefficient of the reference input voltage αV<sub>REF</sub> is defined as:

$$|\alpha V_{REF}| = \frac{\left(\frac{V_{DEV}}{V_{REF}(25^\circ C)}\right) \cdot 10^6}{T_2 - T_1} \dots\dots\dots (\text{ppm}/^\circ\text{C})$$

Where:

T<sub>2</sub> – T<sub>1</sub> = full temperature change.

αV<sub>REF</sub> can be positive or negative depending on whether the slope is positive or negative.

Notes: 5. The dynamic output impedance, R<sub>Z</sub>, is defined as:

$$|Z_{KA}| = \frac{\Delta V_{KA}}{\Delta I_{KA}}$$

When the device is programmed with two external resistors R1 and R2 (see Figure 2.), the dynamic output impedance of the overall circuit, is defined as:

$$|Z_{KA}'| = \frac{\Delta V}{\Delta I} \approx |Z_{KA}| \left(1 + \frac{R1}{R2}\right)$$

**Test Circuits**

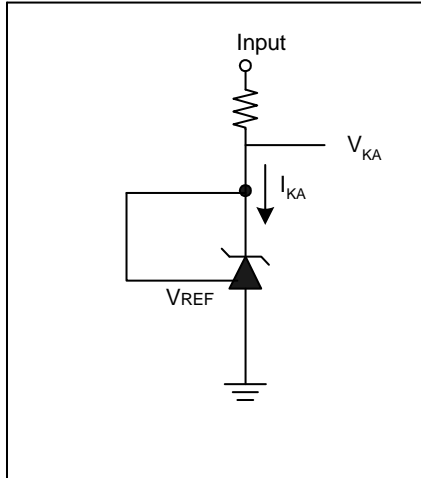
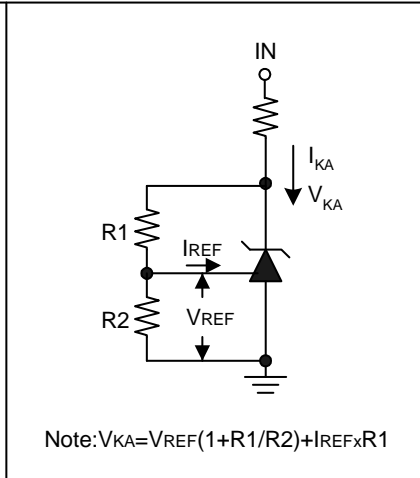

Fig 1. Test Circuit for  $V_{KA} = V_{REF}$



Note:  $V_{KA} = V_{REF}(1 + R1/R2) + I_{REF} \times R1$

Fig 2. Test Circuit for  $V_{KA} > V_{REF}$

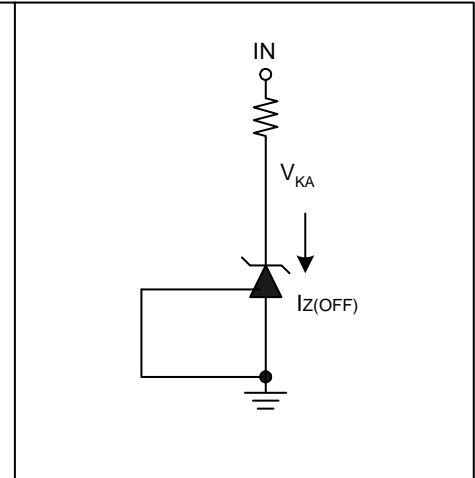
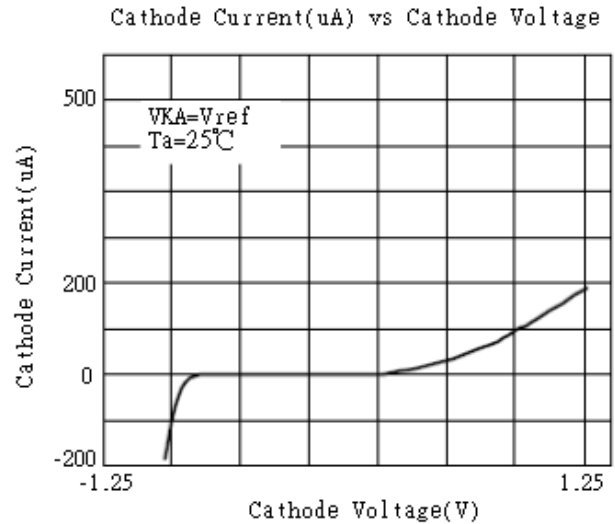
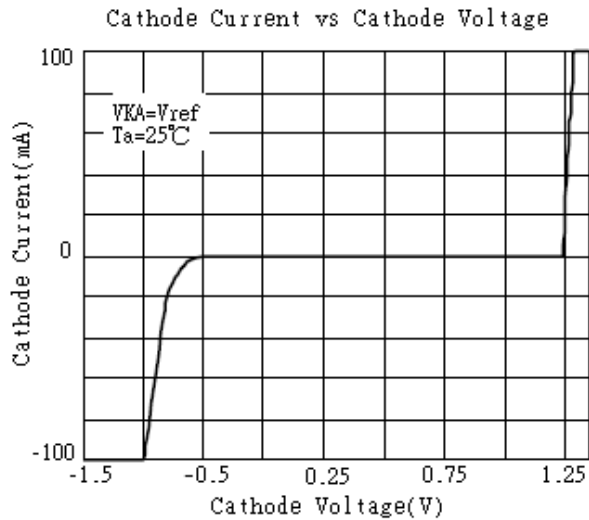
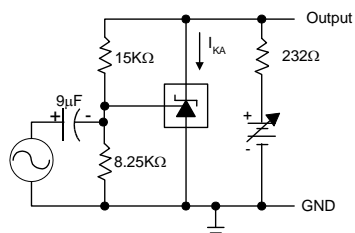
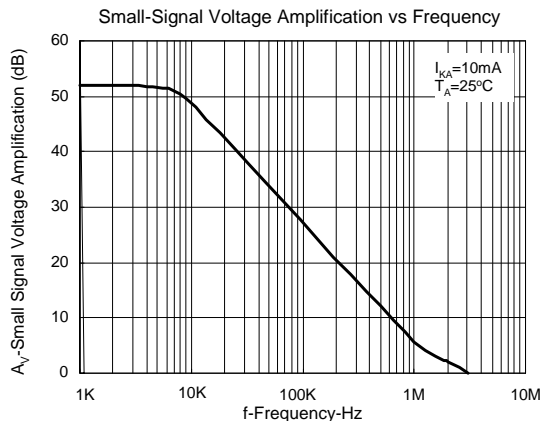

Fig 3. Test Circuit for Off-State Current

**Typical Performance Characteristics**



**Typical Performance Characteristics (cont.)**



Test Circuit for Voltage Amplification

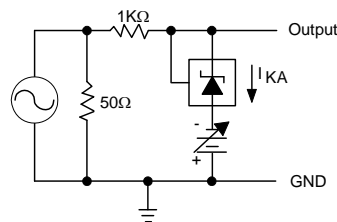
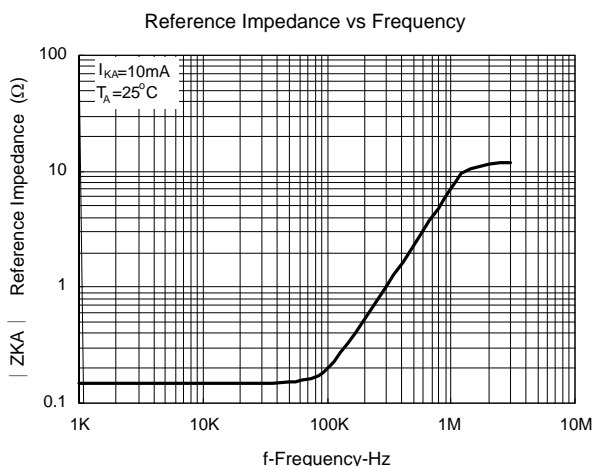

Test Circuit for Reference Impedance

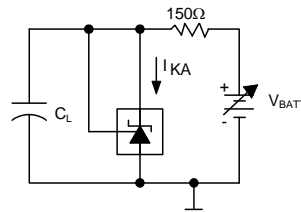
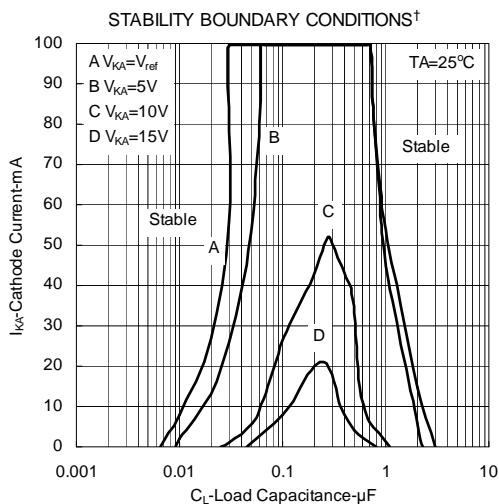

Test Circuit for Curve A

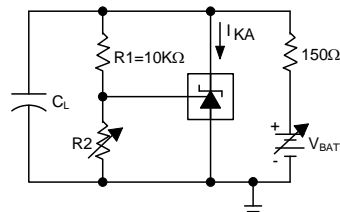

Test Circuit for Curve B, C, and D

†The areas under the curves represent conditions that may cause the device to oscillate. For curves B, C, and D, R2 and V+ were adjusted to establish the initial V<sub>KA</sub> and I<sub>KA</sub> conditions with C<sub>L</sub>=0. V<sub>BATT</sub> and C<sub>L</sub> were then adjusted to determine the ranges of stability.

**Application Examples**

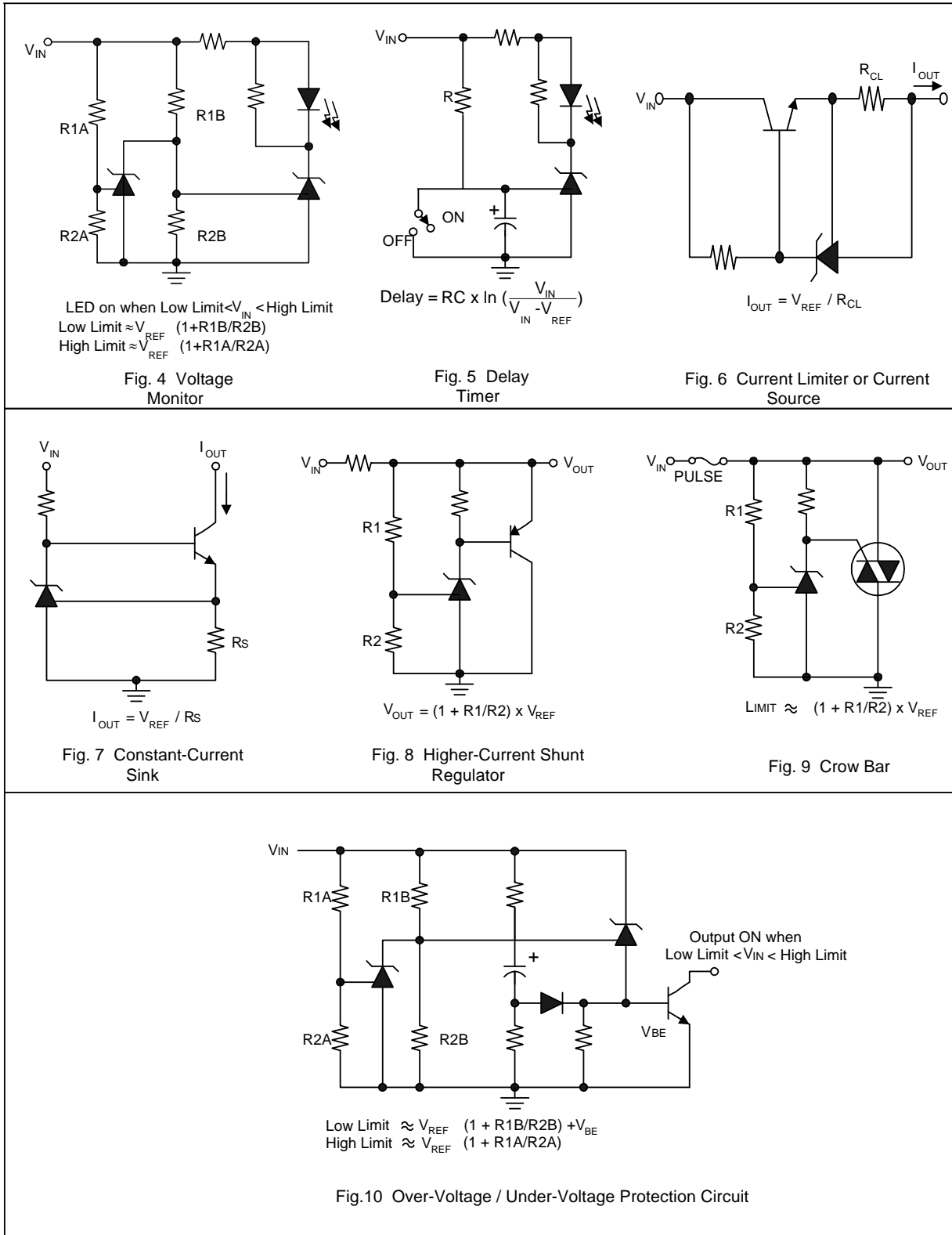

### Ordering Information

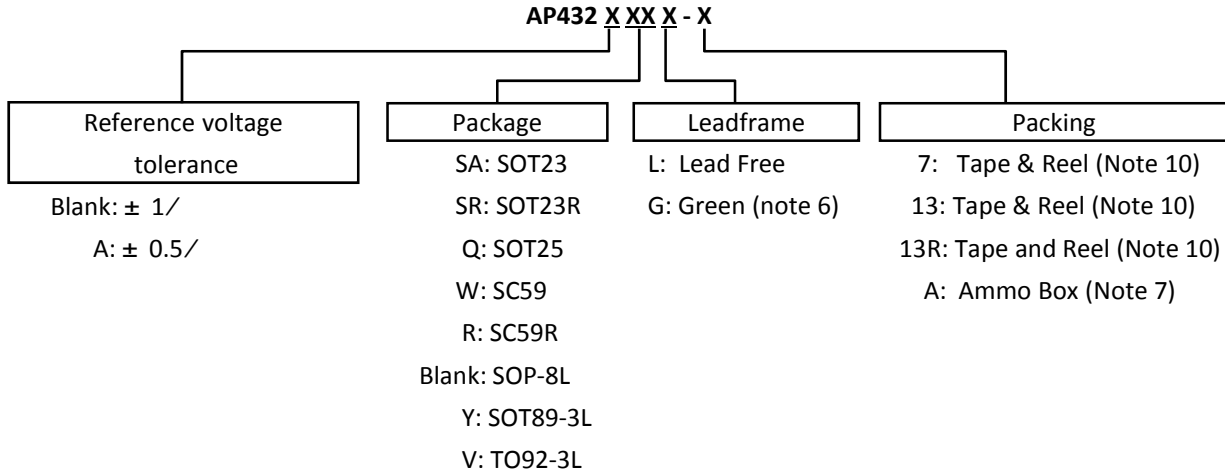

Device (Note 8)	Package Code	Packaging (Note 9)	7"/13 Tape and Reel		Ammo Box	
			Quantity	Part Number Suffix (Note 10)	Quantity	Part Number Suffix
AP432(A)SAG-7	SA	SOT23	3000/Tape & Reel	-7	NA	NA
AP432(A)SRG-7	SR	SOT23R	3000/Tape & Reel	-7	NA	NA
AP432(A)QL-7	Q	SOT25	3000/Tape & Reel	-7	NA	NA
AP432(A)QG-7	Q	SOT25	3000/Tape & Reel	-7	NA	NA
AP432(A)WL-7	W	SC59	3000/Tape & Reel	-7	NA	NA
AP432(A)WG-7	W	SC59	3000/Tape & Reel	-7	NA	NA
AP432(A)RL-7	R	SC59R	3000/Tape & Reel	-7	NA	NA
AP432(A)RG-7	R	SC59R	3000/Tape & Reel	-7	NA	NA
AP432(A)G-13		SOP-8L	2500/Tape & Reel	-13	NA	NA
AP432(A)YL-13	Y	SOT89-3L	2500/Tape & Reel	-13	NA	NA
AP432(A)YG-13	Y	SOT89-3L	2500/Tape & Reel	-13	NA	NA
AP432(A)YG-13R	Y	SOT89-3L	2500/Tape & Reel	-13R	NA	NA
AP432(A)VL-A	V	TO92-3L	NA	NA	2000/Box	A
AP432(A)VG-A	V	TO92-3L	NA	NA	2000/Box	A

- Notes:
6. SOP-8L, SOT23 and SOT23R are available in "Green" products only.
  7. Ammo Box is for TO92-3L Spread Lead.
  8. Suffix "A" denotes AP432A device.
  9. Pad layout as shown on Diodes Inc. suggested pad layout document AP02001, which can be found on our website at <http://www.diodes.com/datasheets/ap02001.pdf>.
  10. Details of tape and reel options can be seen in document AP2007, which can be found on our website at <http://www.diodes.com/datasheets/ap02007.pdf>



**Marking Information**

**(1) SC59 and SC59R**

**( Top View )**

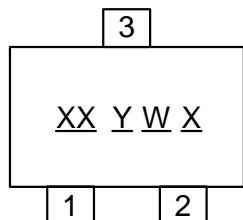

XX : Identification code  
Y : Year 0~9  
W : Week : A~Z : 1~26 week;  
a~z : 27~52 week; z represents  
52 and 53 week  
X : A~Z : Green  
a~z : Lead Free

**(2) SOT23 and SOT23R**

**( Top View )**

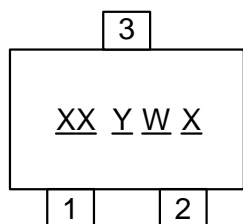

XX : Identification code  
Y : Year 0~9  
W : Week : A~Z : 1~26 week;  
a~z : 27~52 week; z represents  
52 and 53 week  
X : A~Z : Green

**(3) SOT25**

**( Top View )**

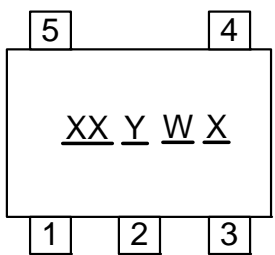

XX : Identification code  
Y : Year 0~9  
W : Week : A~Z : 1~26 week;  
a~z : 27~52 week; z represents  
52 and 53 week  
X : A~Z : Green  
a~z : Lead Free

**(4) SOP-8L**

**( Top View )**

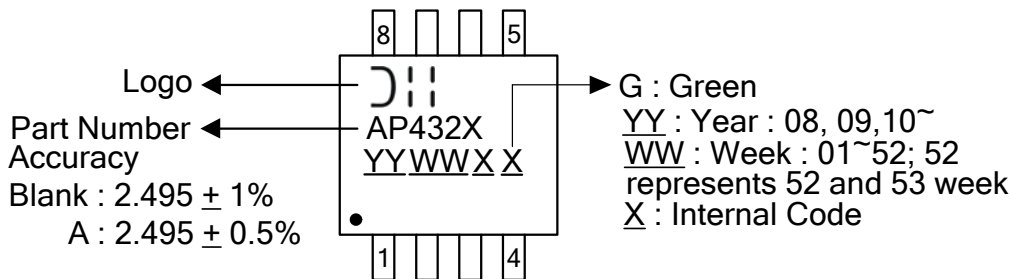

**Marking Information (cont.)**

**(5) SOT89-3L**

**( Top View )**

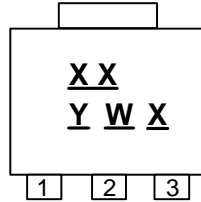

XX : Identification code  
Y : Year : 0~9  
W : Week : A~Z : 1~26 week;  
a~z : 27~52 week;  
z represents 52 and 53 week  
X : Internal code  
A~Z : Green  
a~z : Lead Free

**(6) TO92-3L**

**( Top View )**

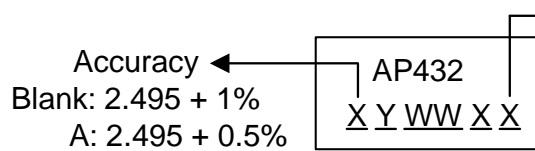

G : Green  
L : Lead Free  
Y : Year : 0~9  
WW : Week : 01~52; 52  
represents 52 and 53 week  
X : Internal Code

**Identification Code Table**

Device	Package (Note 11)	Identification Code	Date Code
AP432SA	SOT23	D3	YM
AP432ASA	SOT23	D4	YM
AP432SR	SOT23R	D7	YM
AP432ASR	SOT23R	D8	YM
AP432Q	SOT25	B7	YM
AP432AQ	SOT25	B8	YM
AP432W	SC59	B3	YM
AP432AW	SC59	B4	YM
AP432R	SC59R	B5	YM
AP432AR	SC59R	B6	YM
AP432Y	SOT89	B1	YM
AP432AY	SOT89	B2	YM

Notes: 11. For packaging details, go to our website at <http://www.diodes.com/datasheets/ap02007.pdf>.

**Package Outline Dimensions (All Dimensions in mm)**

**(1) Package type: SOT25**

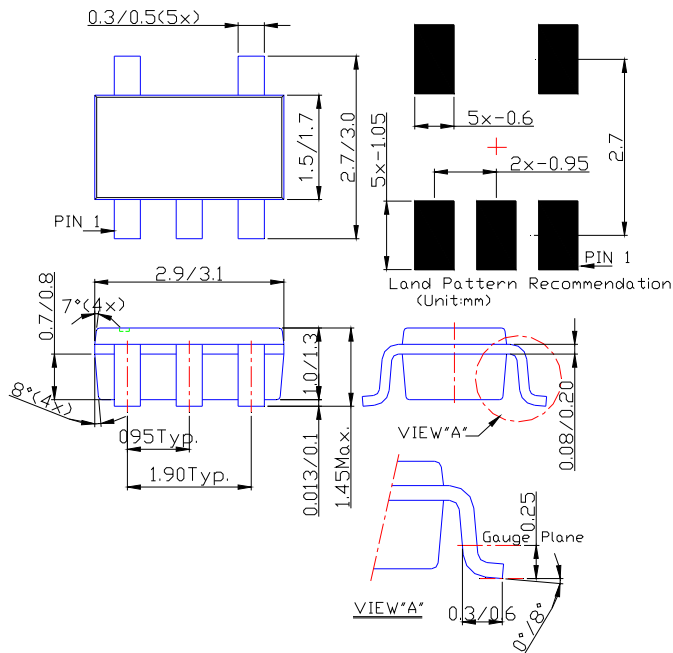

**(2) Package Type: SC59 and SC59R**

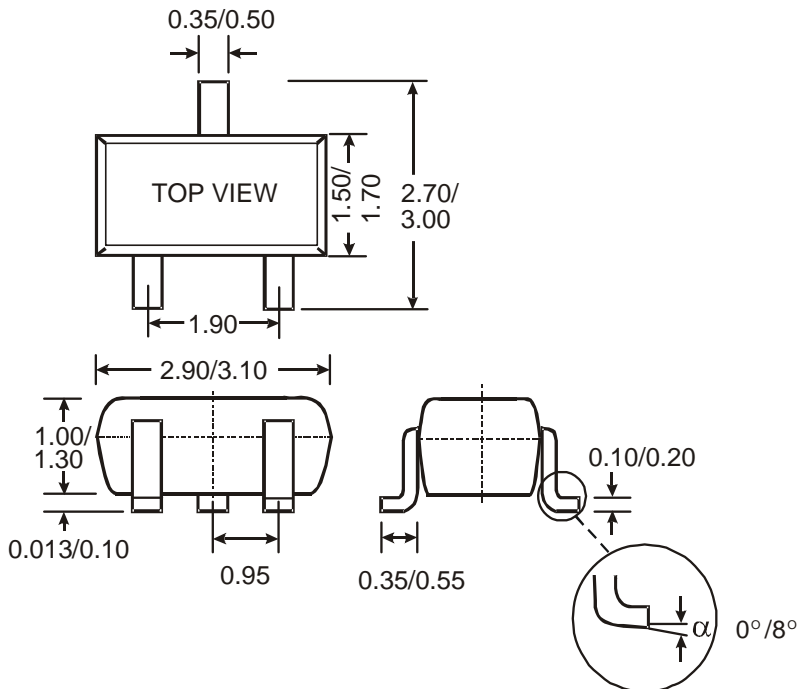

**Package Outline Dimensions (cont.)**

**(3) Package Types: SOT23 and SOT23R**

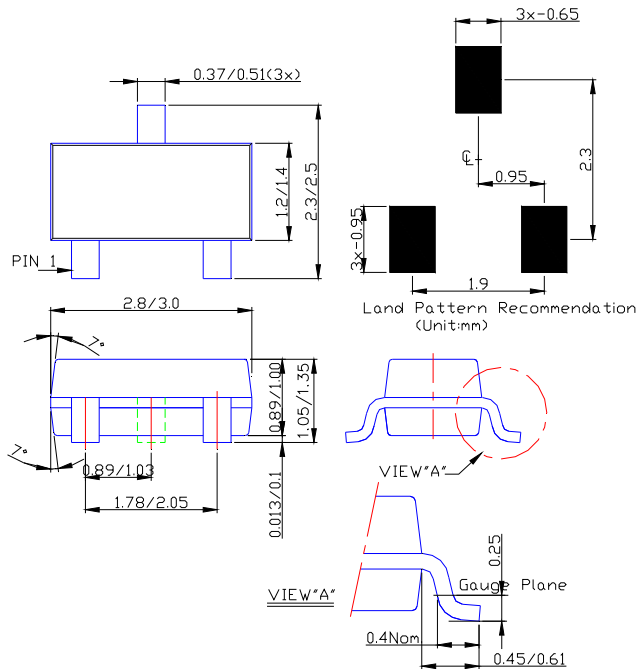

**(4) Package Type: SOP-8L**

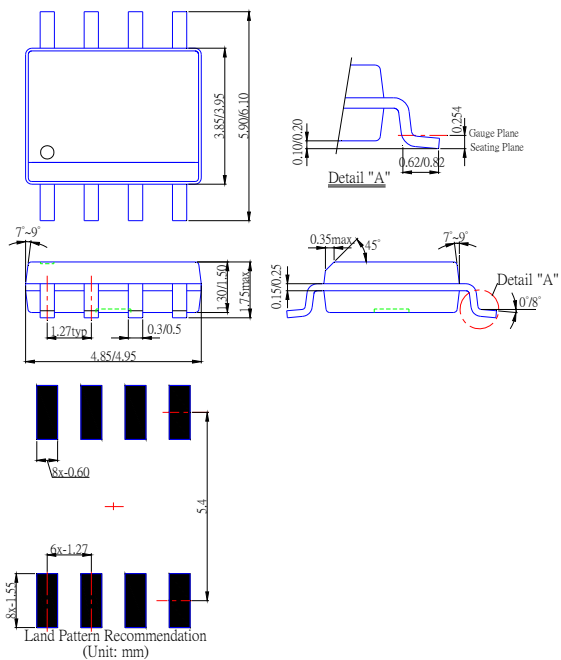

**Package Outline Dimensions (cont.)**

**(5) Package Type: SOT89-3L**

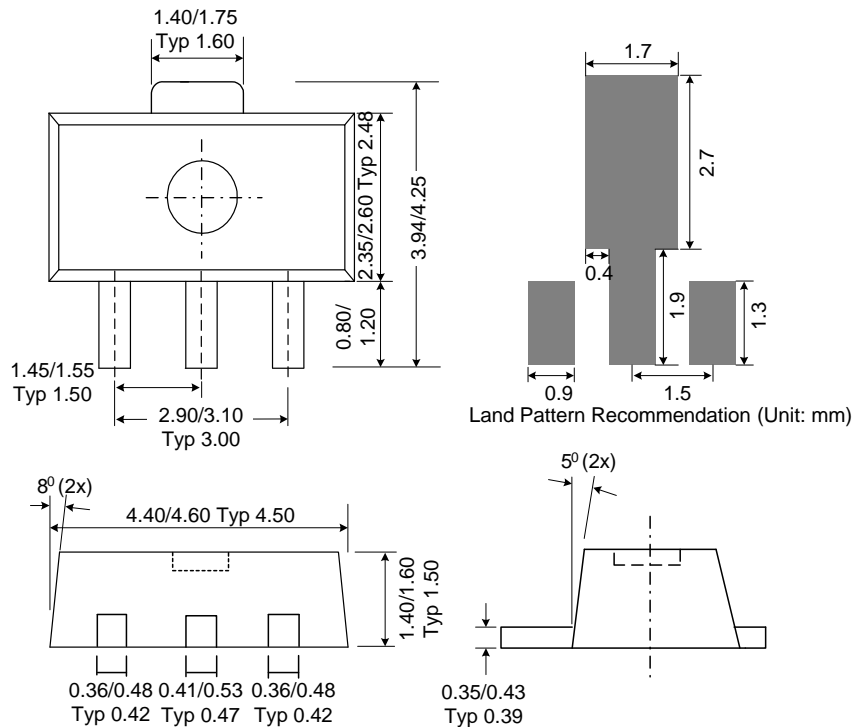

**(6) Package Type: TO92-3L for Ammo pack**

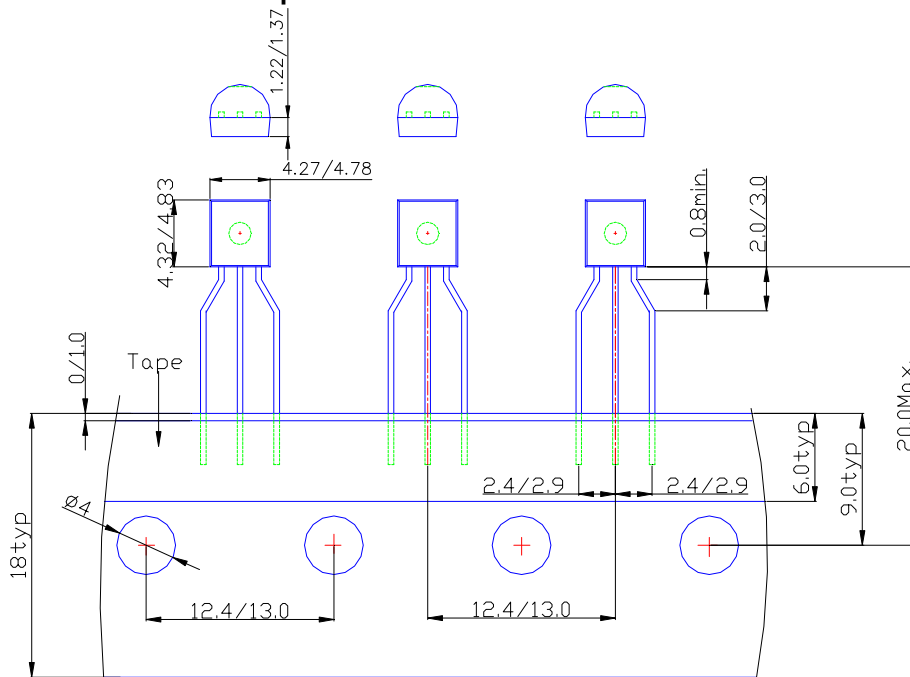

**IMPORTANT NOTICE**

DIODES INCORPORATED MAKES NO WARRANTY OF ANY KIND, EXPRESS OR IMPLIED, WITH REGARDS TO THIS DOCUMENT, INCLUDING, BUT NOT LIMITED TO, THE IMPLIED WARRANTIES OF MERCHANTABILITY AND FITNESS FOR A PARTICULAR PURPOSE (AND THEIR EQUIVALENTS UNDER THE LAWS OF ANY JURISDICTION).

Diodes Incorporated and its subsidiaries reserve the right to make modifications, enhancements, improvements, corrections or other changes without further notice to this document and any product described herein. Diodes Incorporated does not assume any liability arising out of the application or use of this document or any product described herein; neither does Diodes Incorporated convey any license under its patent or trademark rights, nor the rights of others. Any Customer or user of this document or products described herein in such applications shall assume all risks of such use and will agree to hold Diodes Incorporated and all the companies whose products are represented on Diodes Incorporated website, harmless against all damages.

Diodes Incorporated does not warrant or accept any liability whatsoever in respect of any products purchased through unauthorized sales channel.

Should Customers purchase or use Diodes Incorporated products for any unintended or unauthorized application, Customers shall indemnify and hold Diodes Incorporated and its representatives harmless against all claims, damages, expenses, and attorney fees arising out of, directly or indirectly, any claim of personal injury or death associated with such unintended or unauthorized application.

Products described herein may be covered by one or more United States, international or foreign patents pending. Product names and markings noted herein may also be covered by one or more United States, international or foreign trademarks.

**LIFE SUPPORT**

Diodes Incorporated products are specifically not authorized for use as critical components in life support devices or systems without the express written approval of the Chief Executive Officer of Diodes Incorporated. As used herein:

A. Life support devices or systems are devices or systems which:

1. are intended to implant into the body, or
2. support or sustain life and whose failure to perform when properly used in accordance with instructions for use provided in the labeling can be reasonably expected to result in significant injury to the user.

B. A critical component is any component in a life support device or system whose failure to perform can be reasonably expected to cause the failure of the life support device or to affect its safety or effectiveness.

Customers represent that they have all necessary expertise in the safety and regulatory ramifications of their life support devices or systems, and acknowledge and agree that they are solely responsible for all legal, regulatory and safety-related requirements concerning their products and any use of Diodes Incorporated products in such safety-critical, life support devices or systems, notwithstanding any devices- or systems-related information or support that may be provided by Diodes Incorporated. Further, Customers must fully indemnify Diodes Incorporated and its representatives against any damages arising out of the use of Diodes Incorporated products in such safety-critical, life support devices or systems.

Copyright © 2011, Diodes Incorporated

[www.diodes.com](http://www.diodes.com)