

Anderson Power Products' family of Euro Battery Connectors (EBC) exceeds all the requirements of DIN 43589-1 and EN 1175-1. The connector design incorporates an innovative, cost effective contact carrier for ease of assembly.

The connectors have a Degree of Protection of IP23 per IEC 60529. The acid resistance and temperature range of the PBT-PC housing exceeds the requirements of EN 1175-1. Contacts are pure copper with silver plate for maximum conductivity.

All materials meet RoHS requirements and are selected to ensure years of reliable service under adverse battery environments.

Features

- **Sturdy advanced polymer housings**
PBT-PC alloy housings provides superior resistance to acids and temperature extremes
- **DIN 43589-1 voltage keying**
Dry-cell, wet-cell & universal keying plugs coded for 24 / 36 / 48 / 72 / 80 & 96 volts DC
- **Mating compatibility with connectors of other manufacturers**
APP "E" series connectors offer dimensional compatibility for air tube and auxiliary contacts over and above the DIN 43589-1 compatibility of housings and main contacts



- **Silver plated pure copper contacts**
For lowest voltage drop and superior performance

SPECIFICATIONS

Electrical		Mechanical	
Current Rating (Amperes) *		Life	
UL	220	a. No Load (mating cycles)	>5000
EN1175-1:1998	190	b. Under Load (Hot Plug 5 mating cycles @96V)	400A
CSA	160	Average Mating / Unmating Force (lbf)	
Voltage Rating		(N)	
UL / CSA	600	Degree of Protection	
EN1175-1:1998	150	IP23	
Wire Range		Acid Resistance	
- Power Contacts - AWG (mm ²)	#6 to 1/0 (16 / 50)	1.38g / cm ³	
- Auxiliary Contacts - AWG (mm ²)	#12 to #10 (4 / 6)	Contact Retention - minimum (lbf)	
Dielectric Withstanding Voltage (AC)		(N)	
2,200		100	
Average Contact Resistance (micro-ohms)		445	
Operating Temperature (°C)		Air Tube Rating	
-25° to 105°		2 bar	
(°F)		-13° to 221°	
		Materials	
		Housing	
		PBT/PC blend, glass filled	
		Contacts	
		Copper alloy, silver plate	
		Hardware	
		Steel, zinc chromate plate	

* Current derating curves must be observed as current capacity will vary dependent on wire cross section and ambient temperature. Maximum current carrying capacity is measured at 40°C / 104°F using the maximum wire cross section permissible, crimped to contacts using APP recommended tooling.

ORDERING INFORMATION

Connector Part Number Selection

Series	Gender	Main Contact	Handle	Coding Key	Auxiliary Contacts & Air Tubes	Packaging	
E16	4	25	-	1	0	9	
4	Plug				2	9 Individual	
00	None - Order Separately				0	8 Bulk	
16	16 mm ² / #6 AWG				1	(2) Lower Auxiliary Contacts	
25	25 mm ² / #4 AWG				2	(2) Upper Auxiliary Contacts	
35	35 mm ² / #2 AWG				4	(2) Lower Auxiliary Contacts & (2) Upper Auxiliary Contacts	
50	50 mm ² / #1/0 AWG			0	Grey, Wet Cell	5	Air Tube
0	No			2	Green, Dry Cel	6	Air Tube & (2) Upper Auxiliary Contacts
1	Black			3	Yellow, Universal		

Accessories

Part Number	Description
E160-20	Twin air tube
E16-89	Handle kit - low profile
E32-89	Handle kit - high profile
A320LP-MK	Latch plate for mating side
A320HL-MK	Handle with latch & hardware

ORDERING INFORMATION

Tooling

Part Number	Description
1387G3	Hydraulic tool for power contacts
E160-36	Extraction tool

Note: For tooling die information, see tooling chart on website.

DIMENSIONS

Pin Contact

Part AWG	- Wire -		- ØA -		- ØB -		Number mm ²
	mm	in.	mm	in.	mm	in.	
160-1016	16	#6	8.4	0.33	6.0	0.24	
160-1025	25	#4	11.0	0.43	8.0	0.31	
160-1035	35	#2	12.5	0.49	9.0	0.35	
160-1050	50	#1/0	14.5	0.57	11.0	0.43	

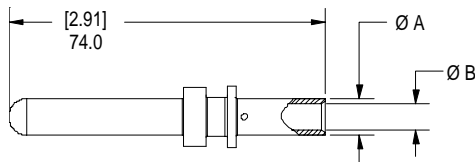

Upper Auxiliary Contact

E160-32 upper auxiliary contact for 4 mm² (#12 AWG)

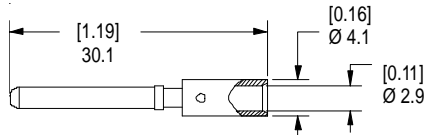

Lower Auxiliary Contact

160-12 lower auxiliary contact for 6 mm² (#10 AWG)

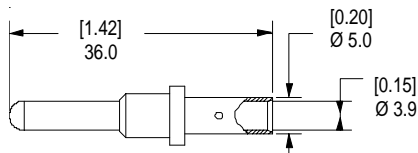

Handle / Lever Assembly / Latch

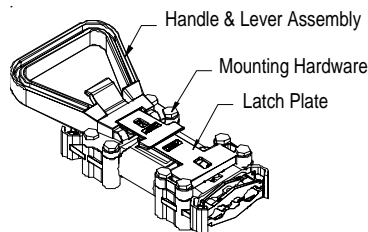

Housing Front View

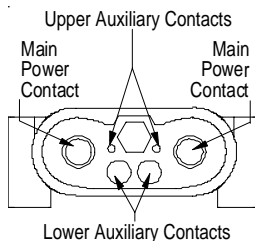

TEMPERATURE CHARTS

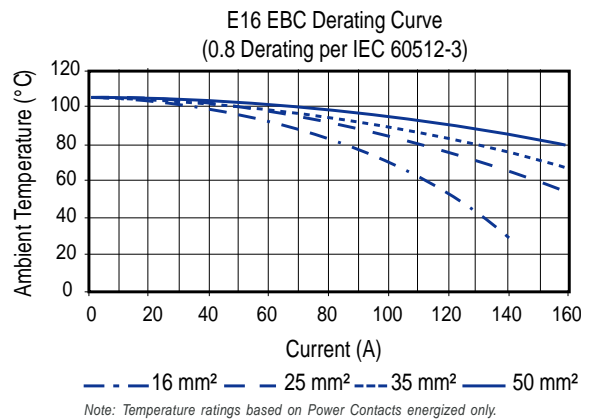
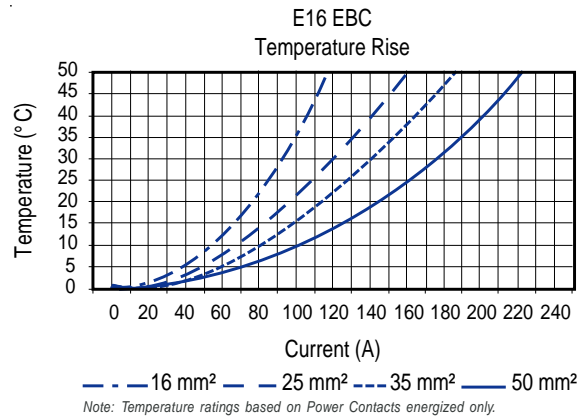

Housing Side View

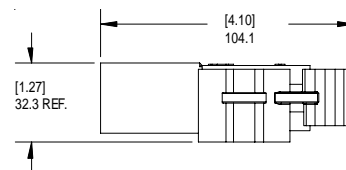

Housing Top View

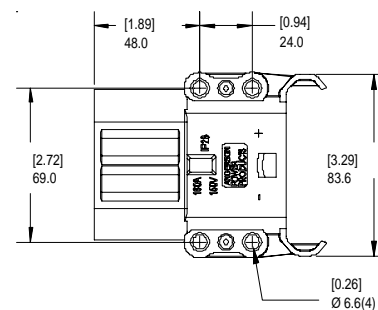

File No. E26226

All Data Subject To Change Without Notice

DS-E16EBCM REV06

HEADQUARTERS: Anderson Power Products®, 13 Pratts Junction Road, Sterling, MA 01564-2305 USA T:978-422-3600 F:978-422-3700

EUROPE: Anderson Power Products® Ltd., Unit 3, Europa Court, Europa Boulevard, Westbrook, Warrington, Cheshire, WA5 7TN United Kingdom T: +44 (0) 1925 428390 F: +44 (0) 1925 428399

ASIA/PACIFIC: IDEAL Anderson Asia Pacific Ltd., Unit 922-928 Topsail Plaza, 11 On Sum Street, Shatin N.T., Hong Kong T: +(852) 2636 0836 F: +(852) 2635 9036

CHINA: IDEAL Anderson Technologies (Shenzhen) Ltd., Block A8 Tantou Western Industrial Park, Songgang Baoan District, Shenzhen, P.R. China 518105 T: +(86) 755 2768 2118 F: +(86) 755 2768 2218

TAIWAN: IDEAL Anderson Asia Pacific Ltd., Taiwan Branch, 4F-2, No.116, Dadun 20th St., Situn District, Taichung City 407, Taiwan (R.O.C.) T: +(886) 4 2310 6451 F: +(886) 4 2310 6460

www.andersonpower.com