

2A Fast Transient Linear Regulator

General Description

The AMS3121 is a high performance linear regulator with very low dropout voltage and excellent transient response. It is designed to operate with wide input voltage range of 1.5 – 7Volts making it ideal for two step conversion while maintaining high efficiency for many power sensitive applications. The device is capable of supplying 2A of output current with a typical dropout voltage of 550mV at 2A. The product is only available in a fixed output voltage option.

The product includes complete short-circuit and thermal protection. The combination of these two internal protection circuits gives the device a comprehensive safety system to safe guard against extreme adverse operating conditions.

The AMS3121 is available in both 3-pin TO-220 and TO-263 packages, and it is rated for -40°C to +125°C temperature range.

Features

- V_{IN} range: 1.5 – 7V
- Fixed output voltage as low as 0.6V
- 2A maximum output current
- 550mV typical dropout voltage at 2A
- Low self noise
- 125 μ A typical supply current
- PSRR >40dB at 10KHz
- Stable with Electrolytic, Tantalum or Ceramic capacitors
- Current Limit protection
- Over-Temperature Shutdown
- -40 to +125°C temperature range
- Available in 3-pin TO-220 and TO-263 surface mount packages
- RoHS & WEEE compliant

Applications

- Set-top Box
- DVD, Blue-ray DVD writers
- LCD TVs and LCD monitors
- Battery Powered Equipment
- Infotainment
- Wireless & RF: applications
- High Efficiency “Green” Laptops & notebook

Typical Application

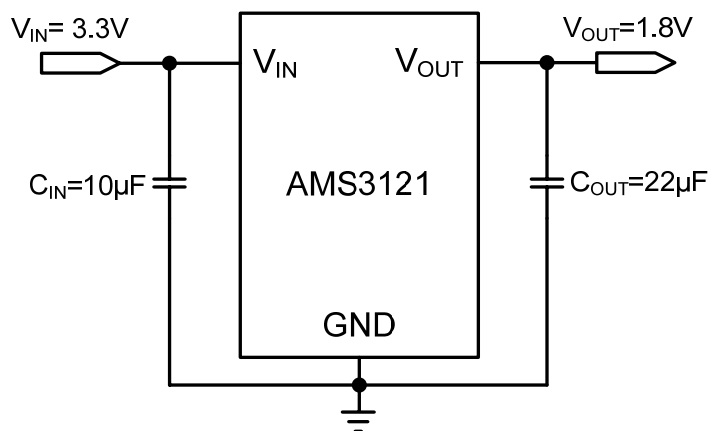

Pin Description (TO-220 and TO-263 3-Pin Package)

Pin #	Symbol	Description
1	V_{IN}	Input supply Voltage. It powers the internal control circuitry and the internal power switch. Bypass V_{IN} with at ceramic capacitor from this pin to ground.
2	GND	Ground
3	V_{OUT}	Output Voltage

Pin Configuration

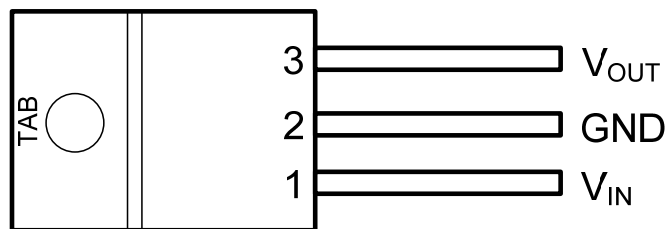

3-Pin TO-220 (T)

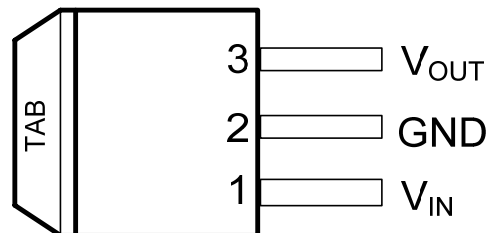

3-Pin TO-263 (M)

2A Fast Transient Linear Regulator

Absolute Maximum Ratings ⁽¹⁾

Maximum Input Supply Voltage (V_{IN})	-0.3V to 15V
Storage Temperature Range	-65°C to 150°C
Lead Temperature	260°C
Junction Temperature	125°C

Recommended Operating Conditions ⁽²⁾

Input Voltage	1.5V to 7V
Ambient Operating Temperature	-40°C to 125°C

Thermal Information

TO-220 3-pin θ_{JA}	50°C/W
TO-263 3-pin θ_{JA} ⁽³⁾	30°C/W

Electrical Characteristics

Unless otherwise noted: $V_{IN}=3.3V$; $V_{OUT}=1.8V$; $C_{IN}=10\ \mu F$; $C_{OUT}=22\ \mu F$; $-40^{\circ}C \leq T_A = T_J \leq 85^{\circ}C$; $T_{J(Max.)} = 125^{\circ}C$; Typical values are $T_A = 25^{\circ}C$

Parameter	Symbol	Conditions	Min.	Typ.	Max.	Units
Output Voltage Accuracy	V_{OUT}		-3		3	%
Maximum Output Current	I_{OUT_Max}		2			A
Load Regulation		$I_{OUT} = 0 - 2A$		0.1		%
Line Regulation		$V_{IN} = 3.0 - 7.0V$; $I_{OUT} = 100mA$		0.2		%
Supply Current	I_{SUP}	$V_{IN} = 3.3V$, $I_o = 0A$		0.2	0.5	mA
Current Limit	I_{LIM}			2.5		A
Dropout Voltage	V_{DO}	$I_{OUT} = 0.1A$; $V_{OUT} = 95\%$ of $V_{OUT(NOM)}$		85		mV
		$I_{OUT} = 0.5A$; $V_{OUT} = 95\%$ of $V_{OUT(NOM)}$		180		
		$I_{OUT} = 1A$; $V_{OUT} = 95\%$ of $V_{OUT(NOM)}$		275		
		$I_{OUT} = 2A$; $V_{OUT} = 95\%$ of $V_{OUT(NOM)}$		550		
PSRR	$\Delta V_{OUT}/\Delta V_{IN}$	$F = 10KHz$ $I_o = 20mA$		40		dB
Output Noise Voltage	e_n	$BW = 100Hz - 100\ KHz$ $C_{OUT} = 10\ \mu F$ $I_{OUT} = 500mA$		125		$\mu V(rms)$
Thermal Shutdown	T_{SD}			145		°C
Thermal Shutdown Hysteresis	T_{SD_HYS}			15		°C

Notes:

- Stresses above those listed in Absolute Maximum Ratings may cause permanent damage to the device.
- Measured on approximately 1" square of 1 oz. copper.
- With package soldering to 0.5in² copper area over backside ground plane or internal power plane θ_{JA} can vary from 20°C/W to >40°C/W depending on mounting technique. The thermal resistance Junction to Case is 45°C/W. Total power dissipation for the switching regulator and the LDO should be taken in consideration when calculating the output current capability of each regulator

Typical Performance Characteristics ($T_A = 25^\circ\text{C}$ unless otherwise specified)

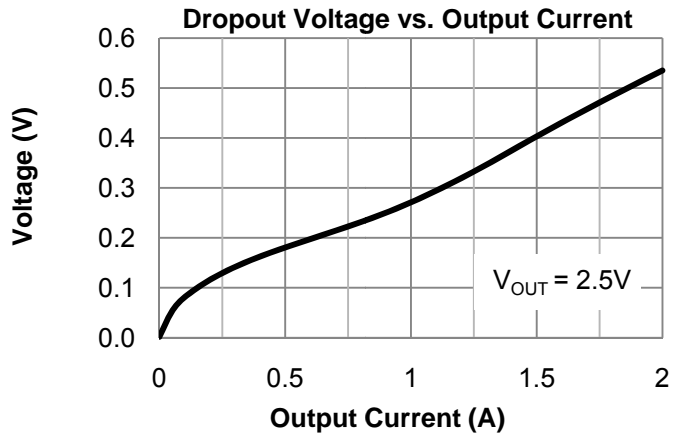
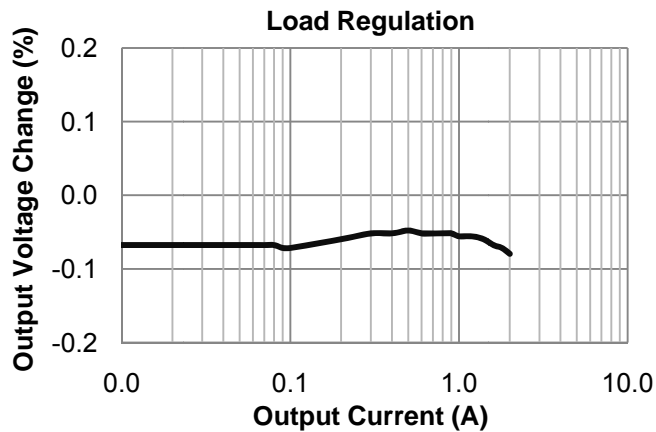
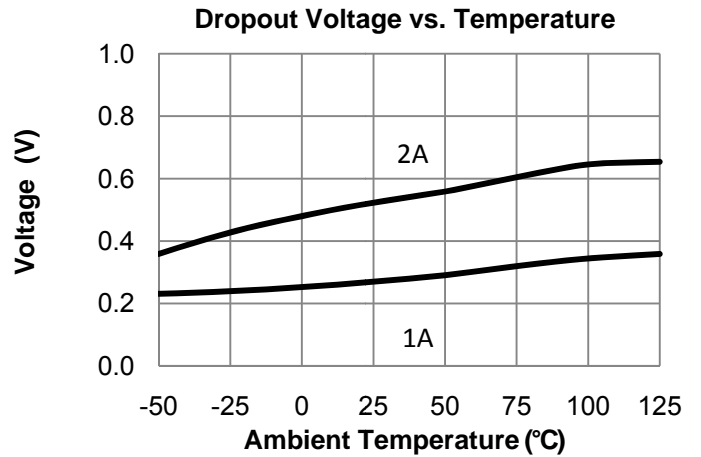
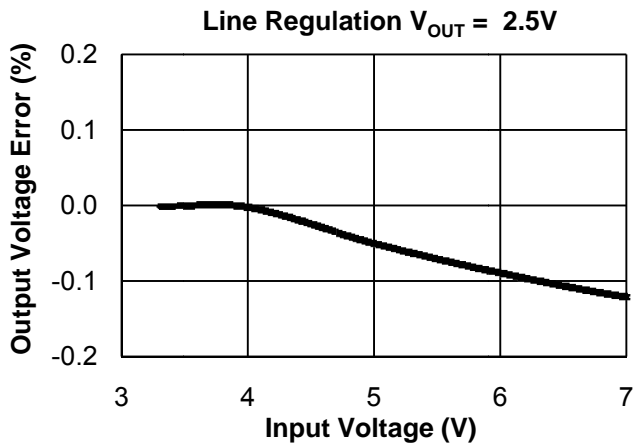
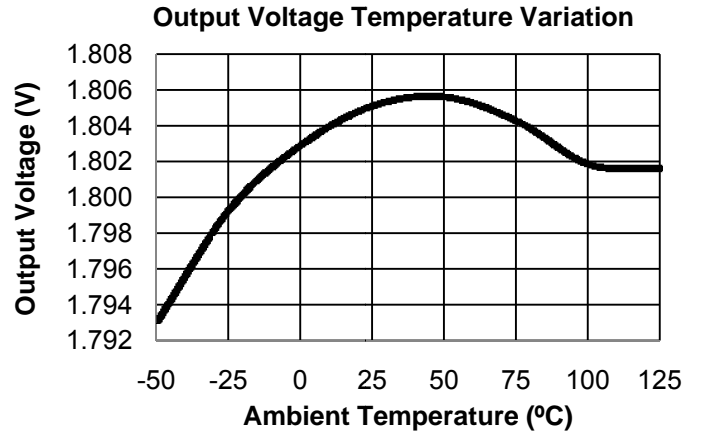
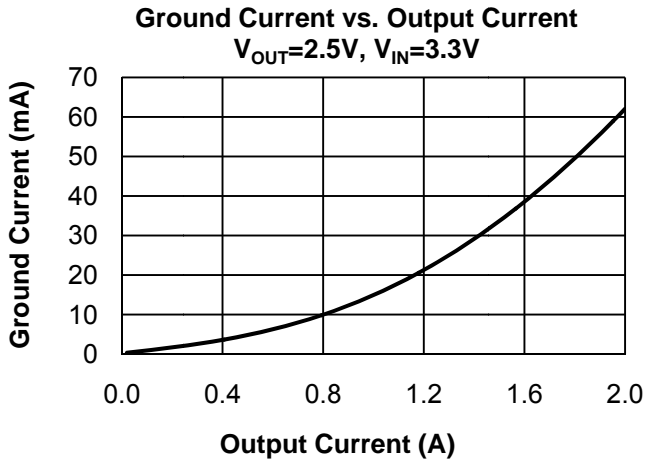

Typical Performance Characteristics ($T_A = 25^\circ\text{C}$ unless otherwise specified)

Load Transient
 100mA to 1.5A. $V_{OUT}=1.8\text{V}$. $V_{IN}=3.3\text{V}$. $C_{IN}=C_{OUT}=22\mu\text{F}$

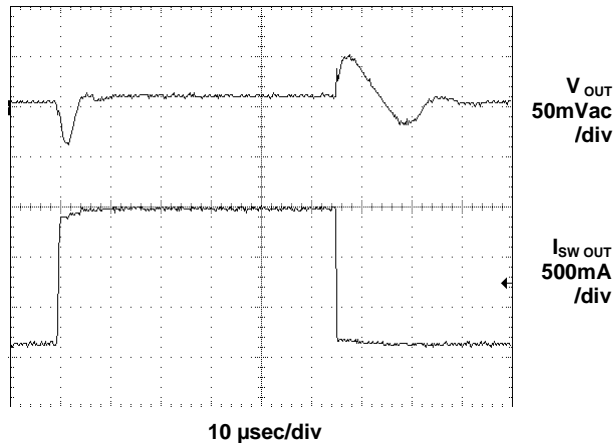

V_{IN} Start-Up
 0-550mA. $V_{OUT}=1.8\text{V}$. $V_{IN}=3.3\text{V}$. $C_{IN}=C_{OUT}=22\mu\text{F}$

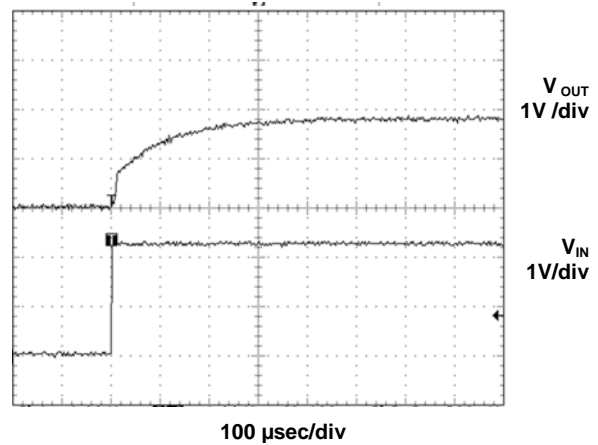

Functional Block Diagram

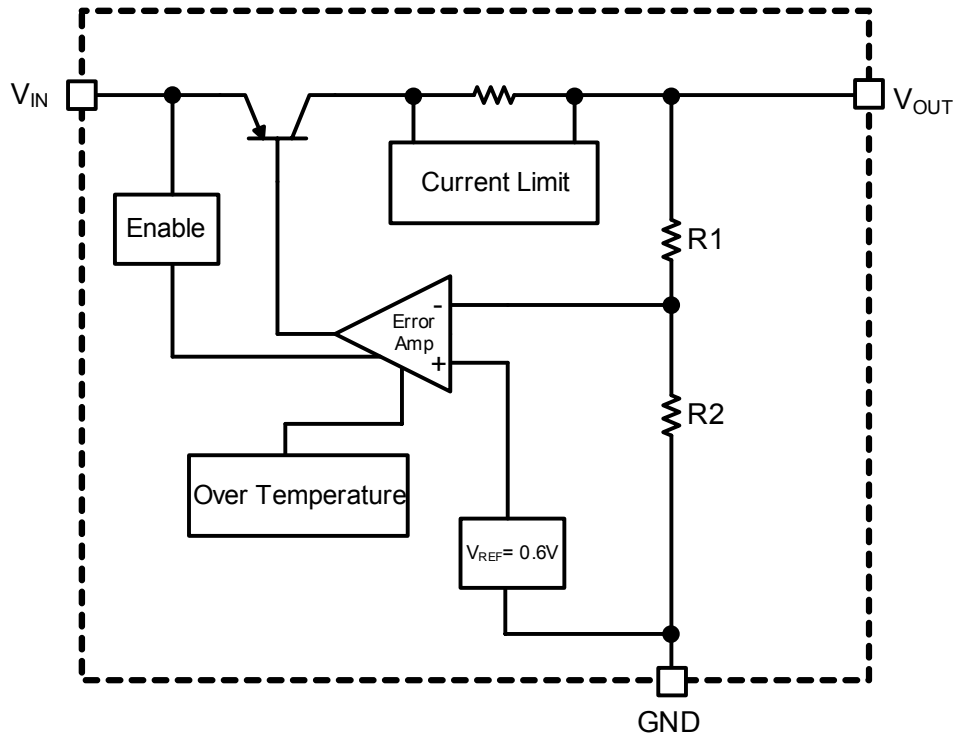

Figure 1: Block Diagram of AMS 3121 3-Pin TO-220 (T) / TO-263 (M)

2A Fast Transient Linear Regulator

Device Summary

The AMS3121 is a high voltage low drop out linear regulator with a current capability of up to 2A. The LDO has an input voltage range of 1.5V to 7V with an output voltage as low as 0.6V and is stable with a wide range of ceramic, tantalum, and electrolytic output capacitors.

Fault Protection

Short circuit and over-temperature shutdown disable the converter and LDO in the event of an overload condition. Overtemp shutdown disables the device when the junction temperature exceeds 145 °C. The output current is internally limited to 2.5A.

Input Capacitor

An input bypass capacitor ranging from 1μF to 10μF is required. The capacitor should be placed as close as possible to the device and not be placed more than 1 inch from the LDO.

Output Capacitor

The output capacitor requirements range from the minimum value required to guarantee stability to larger values required to meet the extreme transient response requirements. Values range from 10 to 22μF X5R ceramic capacitors. Due to the extreme voltage coefficient of X5R ceramic capacitors, the voltage rating should be at least double the maximum applied voltage.

PCB Layout

The following guidelines should be followed to insure proper layout.

1. V_{IN} Capacitor. A low ESR ceramic bypass capacitor must be placed as close to the IC as possible.
2. Ground.
3. For good thermal performance vias are required to couple the exposed tab of both TO-220 and TO-263 packages to the PCB ground plane. The via diameter should be 0.3mm to 0.33mm positioned on a 1.2mm grid.

Output Power and Thermal Limits

The AMS3121 junction temperature and current capability depends on the internal dissipation and the junction to case thermal resistance of the TO-220 and TO-263 exposed tab packages. Additionally, the tab paddle and PCB temperature will be elevated due to the total losses of the LDO and of other circuits mounted to the PCB.

$$T_{jmax} = P_d \cdot \theta_{jc} + T_{pcb} + T_{amb}$$

The internal losses contribute to the junction temperature rise above the paddle and PCB temperature.

2A Fast Transient Linear Regulator

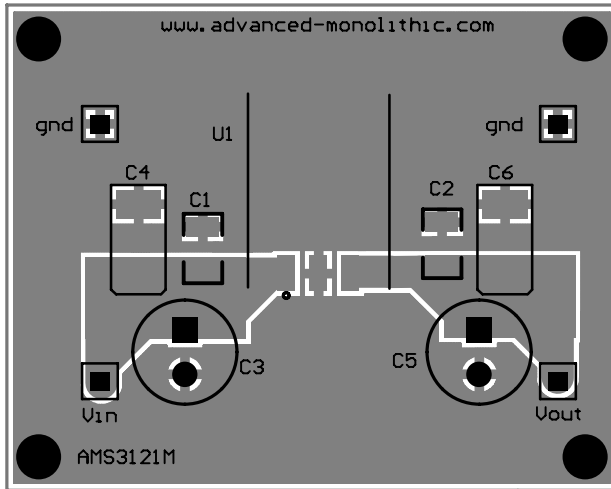

Figure 2: AMS3121 TO-263 3-Pin Option Evaluation Board - Top Side

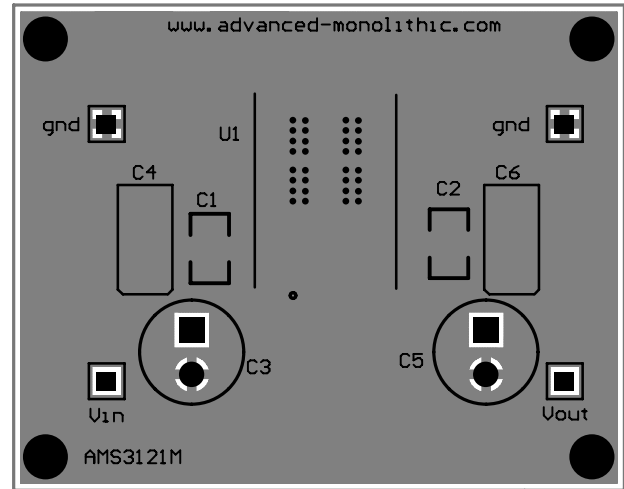
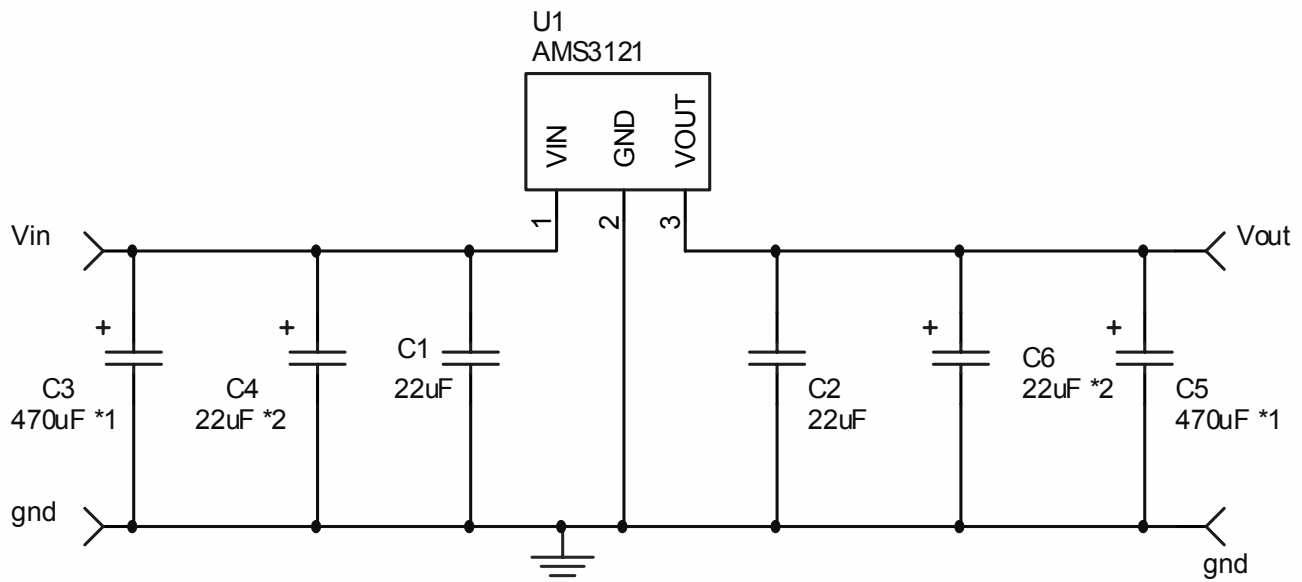

Figure 3: AMS3121 TO-263 3-Pin Option Evaluation Board - Bottom Side



C1, C2 22uF X5R 1210 10V Ceramic Capacitor

*1. Optional Electrolytic Capacitor in place of Ceramic Capacitor

*2. Optional Tantalum Capacitor in place of Ceramic Capacitor

Figure 4: AMS3121 Evaluation Board Schematic

Table 1: Evaluation Board Bill of Materials

Component	Value	Manufacturer	Manufacturer Part Number
C1,C2	22uF, 10V, X5R, 0805, Ceramic	Taiyo Yuden	LMK212BJ226MG-T
C3,C5,C4,C6	Optional		
U1	Low Drop Out Linear Regulator	AMS	AMS3131

Ordering Information

Device	Package
AMS3121T-XX ⁽¹⁾⁽²⁾⁽³⁾	TO-220 3-Pin
AMS3121M-XX ⁽¹⁾⁽²⁾⁽³⁾	TO-263 3-Pin

Notes:

1. Available in tape and reel only. A reel contains 2,500 devices.
2. Available in lead-free package only. Device is fully WEEE and RoHS compliant
3. Need to specify output voltage option ()

Outline Drawing and Landing Pattern

Package dimensions are inches (millimeters) unless otherwise noted.

