

REVISIONS				
SYM	ZONE	ECN, ERN NO.	DATE	APPRD.
A		PROPOSAL	MAY 8/08	L.CHAN

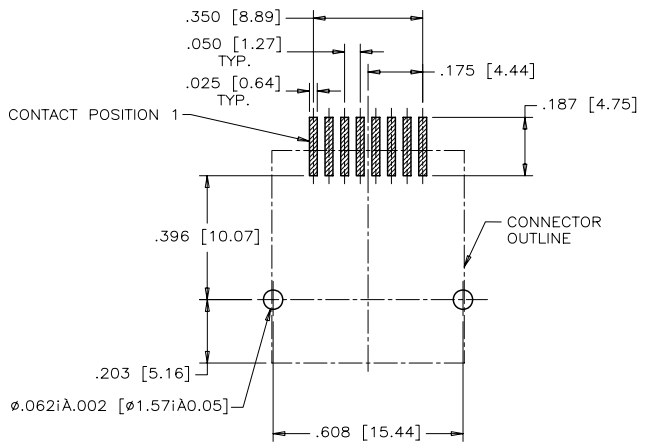
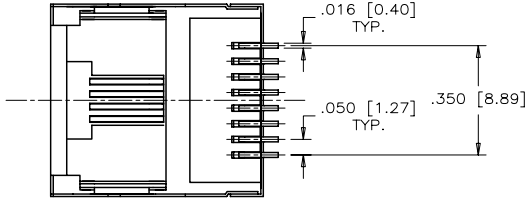

- NOTES:**
- MATERIALS:**
 - HOUSING: HIGH TEMPERATURE RESISTANT NYLON. FLAMMABILITY RATING UL 94V-0. COLOUR: BLACK
 - CONTACTS: PHOSPHOR BRONZE
 - PLATING: GOLD PLATED REFER TO PART NUMBER ON MATING SURFACES. 50 U" [1.27 MICRONS] MIN. NICKEL UNDERPLATE. 100 U" [2.54 MICRONS] MIN. MATTE-TIN ON CONTACT TAILS.
 - SHIELD: COPPER ALLOY, NICKEL PLATED WITH PURE-TIN DIPPED ON SOLDER TAIL
 - COPLANARITY SPECIFICATION:** WITH THE MODULAR JACK SITTING ON A LEVEL SURFACE, THE MAXIMUM GAP BETWEEN THE LEVEL SURFACE AND ALL TERMINAL TAILS AND BOTH FITTING NAILS IS .004 [0.10].

AMPHENOL PART NO.: RJLSE-4X381-01T

GOLD PLATING

- 0 = 06 u"
- 1 = 15 u"
- 2 = 30 u"
- 3 = 50 u"

RECOMMENDED P.C.B. LAYOUT
(COMPONENT SIDE OF BOARD)

DRAWN: J.OUYANG	DATE: MAY 8/08	Amphenol Canada Corp.	
DESIGNED: MT.CHAN	MAY 8/08		
CHECKED: L.CHAN	MAY 8/08	TITLE: SURFACE MOUNT MODULAR JACK, 8 POSITION, 8 CONTACTS, WITH SHIELD, WITH TAPE & REEL PACKAGING-ROHS COMPLIANT	
I. E. APPRD.			
Q. A. APPRD.			
DWG. APPRD.		DWG. DRAWING NO.	REV. A
ENG. REL. NO.		P-RJLSE-4X381-01T	
REF.		DIMENSIONS ARE IN INCHES [mm]	SCALE
		CODE ID. NO. 03554	WT. SURF. SHEET 1 OF 2

THIS DOCUMENT CONTAINS PROPRIETARY INFORMATION AND SUCH INFORMATION MAY NOT BE DISCLOSED TO OTHERS FOR ANY PURPOSE OR USED FOR MANUFACTURING PURPOSES WITHOUT WRITTEN PERMISSION FROM AMPHENOL CANADA CORP.

REVISIONS			
SYM	ZONE	ECN, ERN NO.	DATE
A		PROPOSAL	MAY 8/08
			L.CHAN

← DIRECTION OF CONNECTOR LOADED INTO MACHINE.
LEADS FACING FRONT SIDE

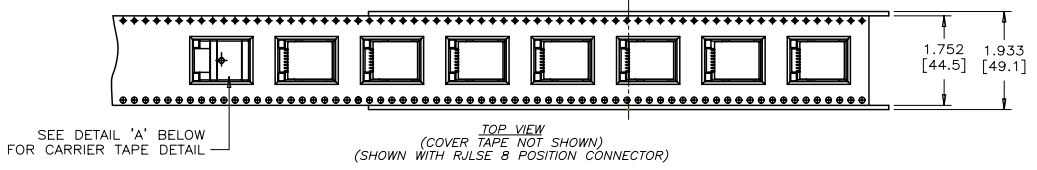

- PACKAGING NOTES:
- ONE REEL SHOULD HOLD 130 CONNECTORS.
 - 25 EMPTY CAVITIES FOR CARRIER TAPE LEADER & 10 EMPTY CAVITIES FOR CARRIER TAPE TRAILER.
 - A FULLY LOADED CARTON SHOULD CONTAIN 5 REELS (650 PCS) OF CONNECTORS.

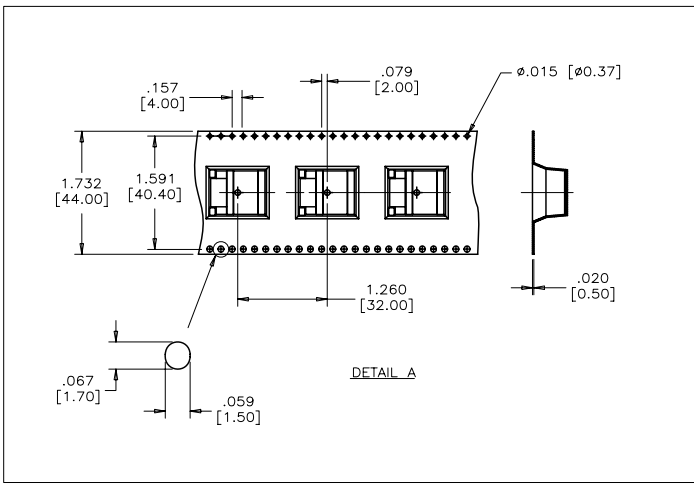
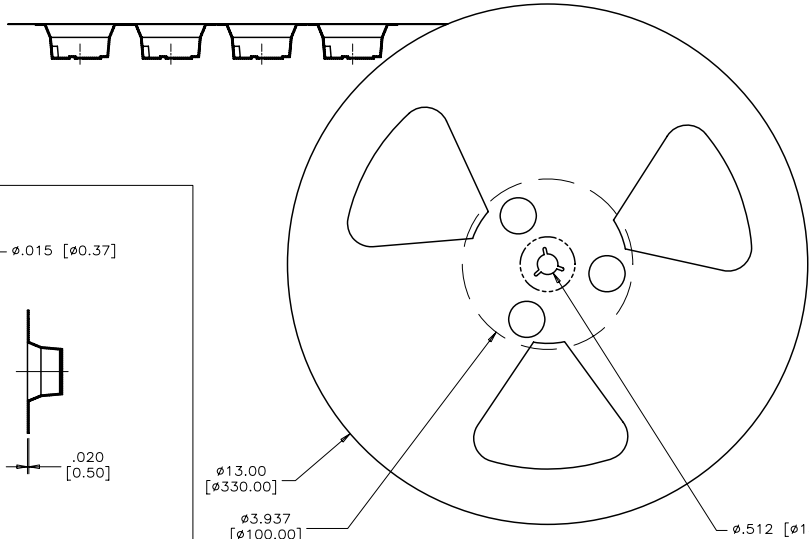

THIS DOCUMENT CONTAINS PROPRIETARY INFORMATION AND SUCH INFORMATION MAY NOT BE DISCLOSED TO OTHERS FOR ANY PURPOSE OR USED FOR MANUFACTURING PURPOSES WITHOUT WRITTEN PERMISSION FROM AMPHENOL CANADA CORP.

DRAWN	J. QUYANG	DATE	MAY 8/08	Amphenol Canada Corp.							
DESIGNED	MT. CHAN	DATE	MAY 8/08								
CHECKED	L. CHAN	DATE	MAY 8/08								
I. E. APPRD.											
Q. A. APPRD.				TITLE	SURFACE MOUNT MODULAR JACK ,8 POSITION, 8 CONTACTS, WITH SHIELD, WITH TAPE & REEL PACKAGING--ROHS COMPLIANT						
DWG. APPRD.				DWG	DRAWING NO.	P-RJLSE-4X381-01T	REV.	A			
ENG. REL. NO.				DIMENSIONS ARE IN	INCHES [mm]	03554	SCALE	NTS	WT.	SURF.	SHEET 2 OF 2