

**PRELIMINARY****Dual Video Amplifier****DESCRIPTION**

AA8632 is a dual video amplifier with 6db gain, 75Ω output buffer and SAG correction, and it supports 3V and 5V operation voltage. The 75Ω buffer is capable of driving two circuits. The SAG could reduce the output coupling capacitor. The power saving circuit provides the power saving function. The IC is available in **8-pin TSSOP (AA8632AP)**, **8-pin SOP (AA8632SP)** and **8-pin DIP (AA8632PP)** package.

**FEATURES**

1. Composite video driver with 6dB gain
2. Support 3V and 5V operation voltage
3. Dual channels video amplifier
4. Output short circuit protection function
5. SAG correction function
6. A load sufficient for driving two circuits
7. Low operating current, 17mA typical
8. Internal voltage clamp circuit
9. TSSOP-8 (AA8632AP), SOP-8 (AA8632SP) and DIP-8 (AA8632PP) package
10. AC-Couple or DC-Couple output

**APPLICATION**

- VCR
- Video Camera
- TV
- Video Player

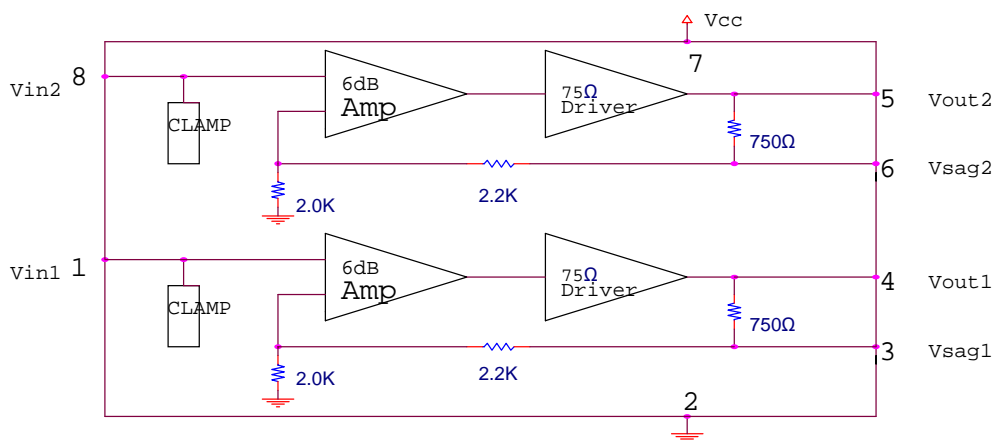
**AA8632 BLOCK DIAGRAM**

**PRELIMINARY****Dual Video Amplifier****■ PIN DESCRIPTION**

Symbol	Pin No	Type	Function
<b>Vin1</b>	1	I	Channel1 input terminal of 1V composite signal
<b>GND</b>	2	-	Ground
<b>Vsag1</b>	3	O	Channel 1 SAG correction output
<b>Vout1</b>	4	O	Channel 1 output
<b>Vout2</b>	5	O	Channel 2 output
<b>Vsag2</b>	6	O	Channel 2 SAG correction output
<b>VCC</b>	7	-	3V or 5V power supply
<b>Vin2</b>	8	I	Channel 2 input terminal of 1V composite signal

**■ ABSOLUTE MAXIMUM RATING**

Ta = 25 °C

Parameter	Symbol	Rating			UNIT	CONDITION
		MIN	TYP	MAX		
Supply Voltage	Vcc	-0.3	3	7	V	
Operating Ambient Temperature	Ta	-40		85	°C	
Storage Temperature	Ts	-40		125	°C	

NOTE : Stress above those listed under “Absolute Maximum Rating” may cause device permanent damage to the device. This stress-rating only factor and functional operation of the device at these or any other conditions above those indicated in the operational section of this specification is not implied. Exposure to absolute maximum rating conditions for an extended period of time may affect device reliability of the device.



**PRELIMINARY**

**Dual Video Amplifier**

■ **ELECTRICAL CHARACTERISTICS**

Ta = 25°C , Vcc = 5V

Parameter	Symbol	Min	Typ	Max	Unit	Condition
Supply Current	Icc		17	20	mA	No input Signal
Voltage Gain	Gv	5.5	6	6.5	dB	Input Signal Freq = 4.43MHz, 1VP-P, measure VO1
Frequency Characteristic	GF	-1	-	1	dB	Input Signal Freq = 7MHz/1MHz, 1VP-P, measure VO1
Clamp Voltage		1.9	2.1	2.3	V	
Output DC level		1.0	1.2	1.4	V	
SAG-Terminal Gain	GSAG	35	45		dB	
Differential Gain	DG		1	3	%	VIN = 1VP-P, refer staircase signal
Differential Phase	DP		1	3	deg	VIN = 1VP-P, refer staircase signal
Crosstalk	CT		-70		dB	V IN=1V 4.43M Sinewave



**PRELIMINARY**

**Dual Video Amplifier**

■ **MEASUREMENT CIRCUIT**

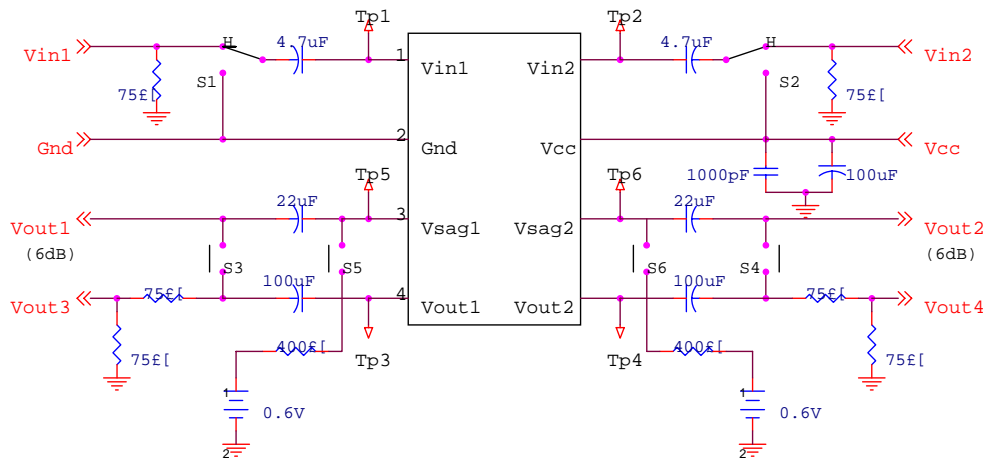

TEST METHODES								
PARAMETER	SYMBOL	SWITCH CONDITIONS						CONDITIONS
		S1	S2	S3	S4	S5	S6	
Supply Current	I <sub>cc</sub>	H	H					7PIN Sink Current
Voltage Gain	G <sub>v</sub>	H	H	ON	ON			Vout1 / Vin, Vout2 / Vin2 at Vin1(Vin2)=1MHz, 1Vpp, Sinewave
Frequency Characteristic	G <sub>f</sub>	H	H	ON	ON			Gv1M Voltage Gain at Vin1(Vin2)=1MHz, 1Vpp Gv10M Voltage Gain at Vin1(Vin2)=7MHz, 1Vpp Gf=Gv10M-Gv1M
Differential Gain	DG	H	H	ON	ON			Measuring Vout3 at Vin1=Staircase Signal
Differential Phase	DP	H	H	ON	ON			Measuring Vout3 at Vin1=Staircase Signal
Crosstalk	CT	H	L	ON	ON			Vout2 / Vout1 at Vin1=4.43MHz 1Vpp Sinewave Vout1 / Vin2 at Vin2=4.43MHz 1Vpp Sinewave
Gain Offset	G <sub>ch</sub>	H	H	ON	ON			Gv1=Vout1 / Vin1, Gv2=Vout2/Vin2 Gch=Gv1-Gv2
Input Clamp Voltage	V <sub>cl</sub>	H	H					Measuring at TP1 (TP2)
SAG Terminal Gain	G <sub>sag</sub>	H	H					TP3(TP4) Voltage; V01A(V02A), TP5(TP6) voltage. Vso1A(Vso2A)
		H	H			ON	ON	TP3(TP4) Voltage; V01A(V02A), TP5(TP6) voltage. Vso1B(Vso2B) G <sub>sag</sub> =20log[(V01B-V01A) / (Vso1A-Vso1B)] G <sub>sag</sub> =20log[(V02B-V02A) / (Vso2A-Vso2B)]

AGAMEM MICROELECTRONICS INCOPERATION RESERVES THE RIGHT TO MAKE CHANGES WITHOUT FURTHER NOTICE TO ANY PRODUCTS HEREIN TO IMPROVE RELIABILITY, FUNCTION OR DESIGN. AGAMEM DOES NOT ASSUME ANY LIABILITY ARISING OUT OF THE APPLICATION OR USE OF ANY PRODUCT OR CIRCUIT DESCRIBED HEREIN; NEITHER DOES IT CONVEY ANY LICENSE UNDER ITS PATENT RIGHTS, NOR THE RIGHTS OF OTHERS.



**PRELIMINARY**

**Dual Video Amplifier**

■ **APPLICATION CIRCUIT 1 – AC-Couple output**

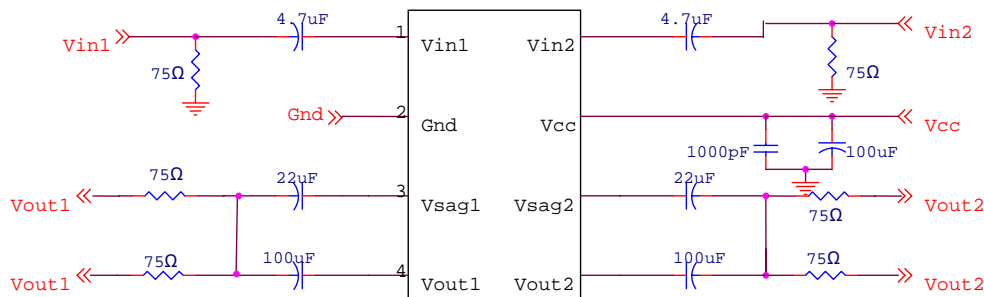

■ **MEASUREMENT CIRCUIT 2 – DC-Couple output**

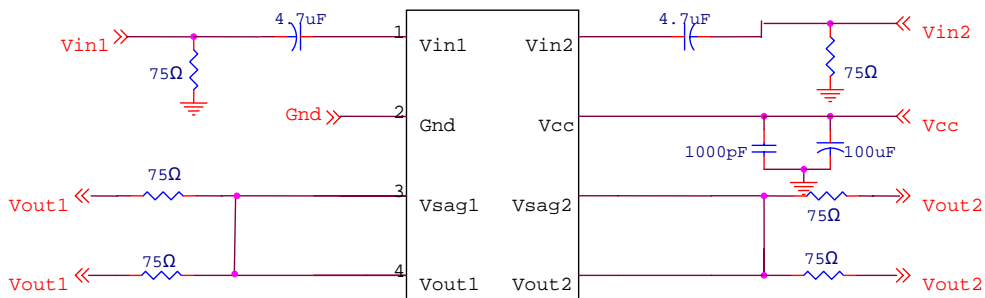

AGAGEM MICROELECTRONICS INCOPERATION RESERVES THE RIGHT TO MAKE CHANGES WITHOUT FURTHER NOTICE TO ANY PRODUCTS HEREIN TO IMPROVE RELIABILITY, FUNCTION OR DESIGN. AGAGEM DOES NOT ASSUME ANY LIABILITY ARISING OUT OF THE APPLICATION OR USE OF ANY PRODUCT OR CIRCUIT DESCRIBED HEREIN; NEITHER DOES IT CONVEY ANY LICENSE UNDER ITS PATENT RIGHTS, NOR THE RIGHTS OF OTHERS.

**PRELIMINARY**

**Dual Video Amplifier**

■ TSSOP-8 – AA8632AP – PACKAGE DIMENSION

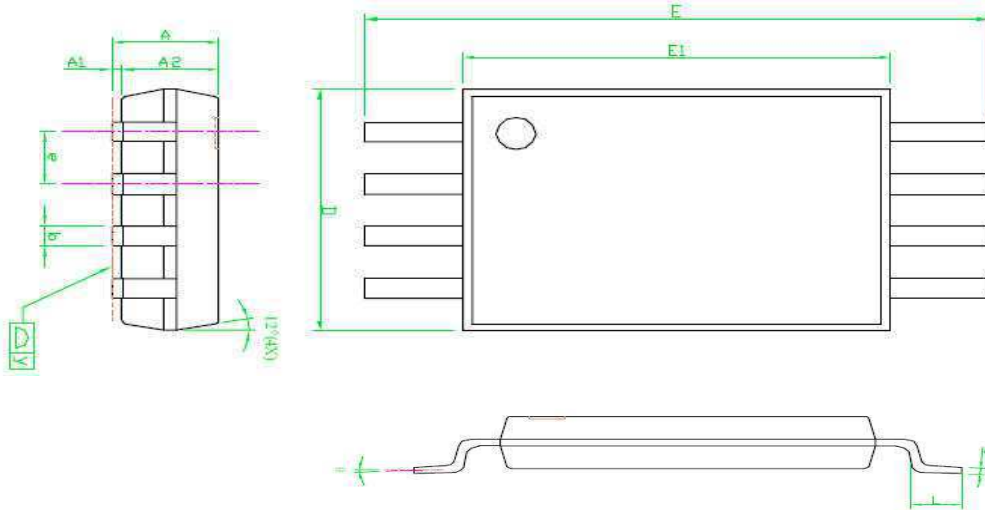

SYMBOLS	DIMENSIONS IN MILLIMETERS			DIMENSIONS IN INCHES		
	MIN	NOM	MAX	MIN	NOM	MAX
A	---	---	1.20	---	---	0.048
A1	0.05	---	0.15	0.002	---	0.006
A2	0.80	1.00	1.05	0.031	0.039	0.041
b	0.19	---	0.30	0.007	---	0.012
C	0.09	---	0.20	0.004	---	0.008
D	2.90	3.00	3.10	0.114	0.118	0.122
E	6.20	6.40	6.60	0.244	0.252	0.260
E1	4.30	4.40	4.50	0.169	0.173	0.177
e	---	0.65	---	---	0.026	---
L	0.45	0.60	0.75	0.018	0.024	0.030
y	---	---	0.10	---	---	0.004
θ	0°	---	8°	0°	---	8°

NOTES:

1. Package body sizes exclude mold flash protrusions or gate burrs.
2. Tolerance  $\pm 0.1 \text{ mm}$  (4 mil) unless otherwise specified
3. Coplanarity: 0.1 mm
4. Controlling dimension is millimeter converted inch dimensions are not necessarily exact.
5. Followed from JEDEC MO-153.

AGAMEM MICROELECTRONICS INCOPERATION RESERVES THE RIGHT TO MAKE CHANGES WITHOUT FURTHER NOTICE TO ANY PRODUCTS HEREIN TO IMPROVE RELIABILITY, FUNCTION OR DESIGN. AGAMEM DOES NOT ASSUME ANY LIABILITY ARISING OUT OF THE APPLICATION OR USE OF ANY PRODUCT OR CIRCUIT DESCRIBED HEREIN; NEITHER DOES IT CONVEY ANY LICENSE UNDER ITS PATENT RIGHTS, NOR THE RIGHTS OF OTHERS.



**PRELIMINARY**

**Dual Video Amplifier**

■ SOP-8 – AA8632SP – PACKAGE DIMENSION

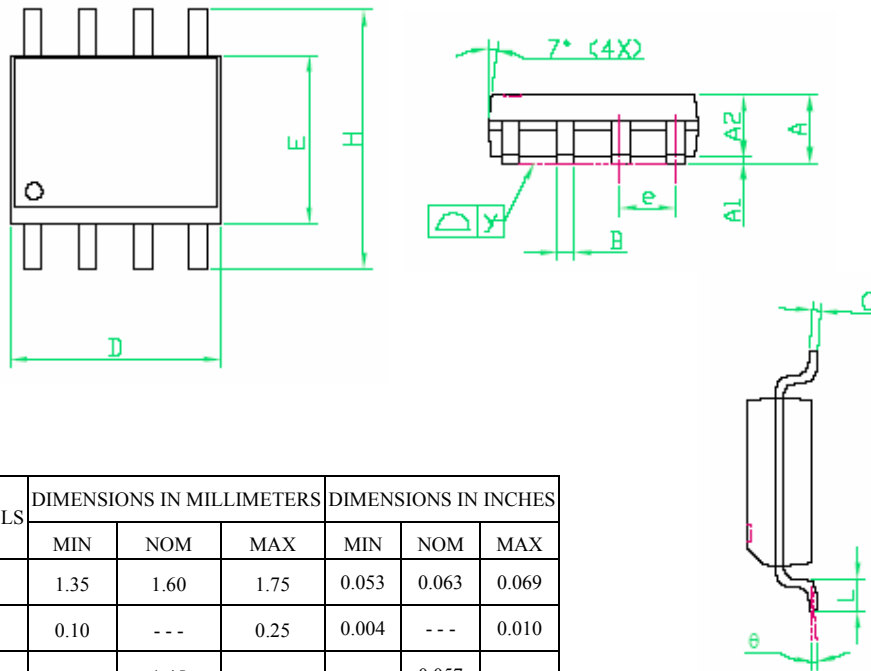

SYMBOLS	DIMENSIONS IN MILLIMETERS			DIMENSIONS IN INCHES		
	MIN	NOM	MAX	MIN	NOM	MAX
A	1.35	1.60	1.75	0.053	0.063	0.069
A1	0.10	---	0.25	0.004	---	0.010
A2	---	1.45	---	---	0.057	---
b	0.33	---	0.51	0.013	---	0.020
C	0.19	---	0.25	0.007	---	0.010
D	4.80	---	5.00	0.189	---	0.197
E	3.80	---	4.00	0.150	---	0.157
e	---	1.27	---	---	0.050	---
H	5.80	---	6.20	0.228	---	0.244
L	0.40	---	1.27	0.016	---	0.050
y	---	---	0.10	---	---	0.004
θ	0°	---	8°	0°	---	8°

NOTES:

1. Package body sizes exclude moldflash protrusions or gate burns.
2. Tolerance  $\pm 0.1 \text{ mm}$  (4 mil) unless otherwise specified
3. Coplanarity: 0.1 mm
4. Controlling dimension is millimeter converted inch dimensions are not necessarily exact
5. Followed from JEDEC MS-012

AGAMEM MICROELECTRONICS INCOPERATION RESERVES THE RIGHT TO MAKE CHANGES WITHOUT FURTHER NOTICE TO ANY PRODUCTS HEREIN TO IMPROVE RELIABILITY, FUNCTION OR DESIGN. AGAMEM DOES NOT ASSUME ANY LIABILITY ARISING OUT OF THE APPLICATION OR USE OF ANY PRODUCT OR CIRCUIT DESCRIBED HEREIN; NEITHER DOES IT CONVEY ANY LICENSE UNDER ITS PATENT RIGHTS, NOR THE RIGHTS OF OTHERS.



**PRELIMINARY**

**Dual Video Amplifier**

■ **DIP-8 – AA8632PP – PACKAGE DIMENSION**

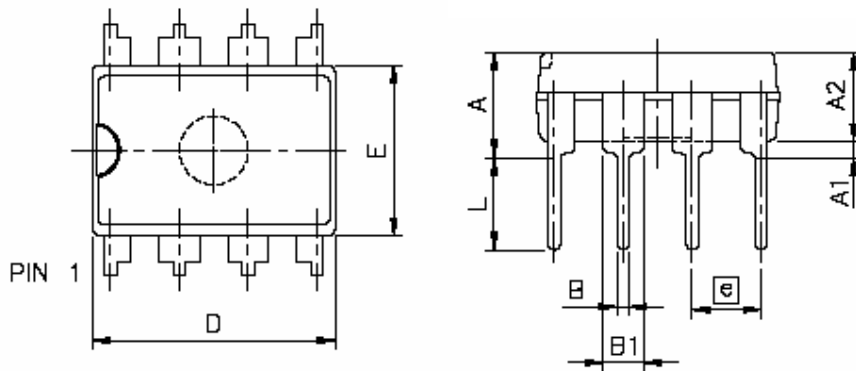

SYMBOL	DIMENSION IN INCH	DIMENSION IN MM
A	0.170 MAX.	4.318 MAX.
A1	0.015 MIN.	0.381 MIN.
A2	0.130±0.005	3.302±0.127
B	0.018 TYP.	0.457 TYP.
B1	0.060 TYP.	1.524 TYP.
C	0.010 NOM.	0.254 NOM.
D	0.362±0.005	9.195±0.127
E	0.252±0.005	6.401±0.127
E1	0.300±0.010	7.62±0.254
EA	0.355±0.020	9.017±0.508
e	0.100 TYP.	2.540 TYP.
L	0.130±0.010	3.302±0.254
θ	0°~15°	0°~15°

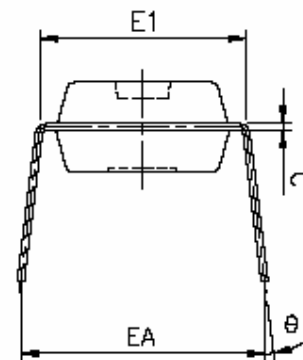

NOTE:  
1. DIMENSION D & E DOES NOT INCLUDE FLASH.

AGAMEM MICROELECTRONICS INCORPORATION RESERVES THE RIGHT TO MAKE CHANGES WITHOUT FURTHER NOTICE TO ANY PRODUCTS HEREIN TO IMPROVE RELIABILITY, FUNCTION OR DESIGN. AGAMEM DOES NOT ASSUME ANY LIABILITY ARISING OUT OF THE APPLICATION OR USE OF ANY PRODUCT OR CIRCUIT DESCRIBED HEREIN; NEITHER DOES IT CONVEY ANY LICENSE UNDER ITS PATENT RIGHTS, NOR THE RIGHTS OF OTHERS.