

# Programmable Attenuators



## Model 3200 Series Model 3200 (E Series) Programmable Attenuators with optional TTL Interface

dc to 2.0 GHz  
dc to 3.0 GHz  
1 Watt



### Features

- /// **Widest Selection of Attenuation Ranges & Step Sizes**
- /// **Available Express Models:** 3200-1, 3200-1E-2, 3200-2, 3201-1, 3201-2, 3206-1  
Other models may be available for Express delivery.
- /// **High Quality Construction & Connectors**
- /// **Special Configurations Available Upon Request**
  - Custom Cell/Step Size Configurations
  - 3.0 GHz and Higher Frequencies

### Description

The 3200 Series Programmable Step Attenuators are designed for use in automatic test equipment and OEM systems operating in the dc to 3 GHz frequency range. This series is available in many standard attenuation ranges and cell configurations. Custom designed configurations are available upon request. Each cell contains a double-pole, double-throw relay that provides a zero path or attenuated path for the RF signal.

Microstrip circuitry and special compensation techniques produce flat attenuation versus frequency characteristics. The microstrip construction, using thick-film circuit elements, ensures product uniformity. To minimize RF leakage, the 3200 Series Attenuators are provided with gold-plated contact areas and feedthrough filters at each control terminal.

### Specifications

**NOMINAL IMPEDANCE:** 50 Ω

**FREQUENCY RANGE:**

- dc to 2.0 GHz: 3200-1, 3200-2, 3201-1, 3201-2, 3205-1, 3205-2, 3205-3, 3206-1, 3209-1
- dc to 3.0 GHz: 3200-1E, 3200-2E, 3201-1E, 3205-3E, 3206-1E, 3209-1E

### CELL CONFIGURATIONS:

Model Number	NO. Cells	Attenuation Range/Steps (dB)	Cell Increments (dB)
3200-1 3200-1E	8	127/1	1, 2, 4, 8, 16, 32, 64*
3200-2 3200-2E	8	63.75/0.25	0.25, 0.5, 1, 2, 4, 8, 16, 32
3201-1 3201-1E	5	31/1	1, 2, 4, 8, 16
3201-2	5	120/10	10, 20, 30, 60**
3205-1	4	70/10	10, 20, 20, 20
3205-2	4	55/5	5, 10, 20, 20
3205-3 3205-3E	4	1.5/0.1	0.1, 0.2, 0.4, 0.8
3206-1 3206-1E	6	63/1	1, 2, 4, 8, 16, 32
3209-1 3209-1E	10	64.5/0.1	0.1, 0.2, 0.4, 0.8, 1, 2, 4, 8, 16, 32

\*64 dB cell comprised of two 32 dB cells  
\*\*60 dB cell comprised of two 30 dB cells

### MAXIMUM SWR:

Freq Range (GHz)	3200-1 3200-2	3200-1E 3200-2E 3201-1E 3205-3E	3201-X 3205-X 3206-X	3206-1E	3209-1	3209-1E
dc - 0.2	1.30	1.25	1.30	1.25	1.35	1.35
0.2 - 1	1.25	1.25	1.25	1.25	1.35	1.35
1 - 2	1.35	1.25	1.35	1.25	1.35	1.35
2 - 3	---	1.40	---	1.35	---	1.45

### INCREMENTAL ATTENUATION ACCURACY:

Frequency Range (GHz)	Accuracy
dc - 0.5	± 0.2 dB or 0.5%
0.5 - 1	± 0.2 dB or 1.0%
1 - 3	± 0.3 dB or 2.0%

**MONOTONICITY:** dc to 3.0 GHz

**INCREMENTAL TEMPERATURE COEFFICIENT:**

- 30 and 32 dB Cells: 0.00005 dB/dB/°C
- All other cells: 0.00002 dB/dB/°C

**POWER RATING:** 1 watt average to 25°C ambient temperature, derated linearly to 0.25 watt @ 71°C. 50 watts peak (5 μsec pulse width; 1% duty cycle)

## Specifications - Con't

MAXIMUM INSERTION LOSS (dB):										
Frequency Range (GHz)	3200-1 3200-2	3200-1E 3200-2E	3201-1 3201-2	3205-X	3201-1E	3205-3E	3206-1	3206-1E	3209-1	3209-1E
dc - 0.5	2.80	2.20	1.80	1.80	1.50	1.25	2.00	1.50	3.50	3.00
0.5 - 1.0	3.50	3.00	2.40	2.30	1.80	1.75	2.70	2.00	4.50	3.50
1.0 - 1.5	4.25	3.20	3.00	2.80	2.25	2.25	3.30	2.50	5.60	4.00
1.5 - 2.0	4.75	3.70	3.75	3.30	2.50	2.50	4.00	2.80	6.70	4.50
2.0-3.0	---	4.90	---	---	3.40	3.40	---	3.70	---	5.50

**POWER COEFFICIENT:** <0.005 dB/dB/watt

**RATED SWITCH LIFE:** 5 million cycles operations per cell @ 0 dBm

**SWITCHING TIME:** 6 msec. maximum at nominal rated voltage

**RELEASE TIME:** 3 msec maximum

**CYCLING RATE:** 5 Hz maximum per relay

**OPERATING VOLTAGE:** +12V (+ 16V maximum; +10V minimum)

**OPERATING CURRENT:**

2 GHz Models: 14 mA typical per cell @ +12V

3 GHz Models: 30 mA typical per cell @ +12V

**TEMPERATURE RANGE (Operating):** -55°C to +71°C

**TEST DATA:** Test data is available at additional cost.

**CONNECTORS:** SMA female connectors per MIL-STD-348 interface dimensions - mate nondestructively with MIL-C-39012 connectors.

**CONTROL TERMINALS:** 0.040 inch. (1 mm) diameter solderable leads. May be used with PC board sockets/receptacles.

**CONSTRUCTION:**

Housing: Aluminum

Connectors: Stainless steel body and beryllium copper contacts.

Control terminals: Brass/Copper, Silver plated

**WEIGHT (Typical):**

3200-1, 3200-2, 3200-1E & 3200-2E: 117 g (4.1 oz)

3201-1 & 3201-1E: 89 g (3.1 oz)

3201-2: 96 g (3.4 oz)

3205-1, 3205-2, 3205-3, 3205-3E: 77 g (2.7 oz)

3206-1, 3206-1E: 99 g (3.5 oz)

3209-1, 3209-1E: 159 g (5.6 oz)

**MODEL NUMBER DESCRIPTION:**

**Example, DC-2 GHz models:**

320X-Y For a basic 2 GHz model\*

320X-Y-1 Add -1 for TTL driver board with a 10 pin ribbon cable connector.

320X-Y-2 Add -2 for TTL driver board with a 15 pin D type connector.

**Example, DC-3 GHz models:**

Add E as in:

320X-YE For a basic 3 GHz model\*

320X-YE-1 Add -1 for a TTL driver board with a 10 pin ribbon cable connector

320X-YE-2 Add -2 for a TTL driver board with a 15 pin D connector

\* Use the Cell Configuration table to determine X and Y for available attenuation ranges.

## CONTROL CONFIGURATION:

**Standard Unit:** One terminal is connected to case ground and the remaining terminals are provided for activation of individual cells. Attenuation is fail-safe to "0" setting in the absence of a control voltage. Application of a voltage (+) to a particular cell causes it to switch to the attenuate position.

**Units with TTL Option:** Units with this option are supplied with a very low profile connectorized TTL interface board mounted directly to the control terminals. This TTL interface option is available with either a 10 pin ribbon cable connector or a 15 pin "D" connector (**limited models**), refer to list below. Each type is supplied with a mating connector. Refer to Physical Dimensions for mating connector pin/wiring details. Two wires are specified for supply voltage and ground. The remaining wires will accept TTL control signals to activate or de-activate a particular attenuation cell. A TTL high will energize a cell to the high attenuation state, whereas a TTL low will maintain a cell in its zero attenuation state.

To order 3200 Series Attenuators with this option add -1 to basic model number for ribbon cable connector and -2 for the "D" connector. Example: Model 3201-1 with a TTL interface board would be 3201-1-1. Mating connector is provided. To order a TTL Driver board separately for an existing 3200 Series Attenuator, use the following:

Basic Model No.	TTL BD Kit Part No.	TTL BD Part No.
	10 Pin Ribbon	15 Pin "D" CONN
3200-1, 3200-1E	101-1781	101-1798-000**
3200-2, 3200-2E	101-1781	101-1798-000**
3201-1, 3201-2E	101-1780	101-1798-001**
3201-2	101-1780	101-1798-001**
3205-1	101-1780	101-1798-001**
3205-2	101-1780	101-1798-001**
3205-3, 3205-3E	101-1780	101-1798-001**
3206-1, 3206-3E	101-1780	N/A
3209-1, 3209-1E	101R-1804-000*	N/A

\* 14 pin ribbon connector.

\*\* 3 FT TTL Interface Cable Part No. 101-1805 supplied with unit.

"R" denoting Rohs compliance

Note: Control is non-latching and requires a continuous control signal for the period of time in which attenuation is required.

# Programmable Attenuators



## TTL DRIVER SPECIFICATIONS:

**INTERFACE CONNECTOR:** Option -1 (Models 3200, 3201, 3205 and 3206): 10 pin .025 square post header on .1 center, mates with Amp connector 746285-1 or equivalent. Option -1 (3209): 14 pin .025 square post header on .1 center, mates with Amp connector 746285-2 or equivalent. Option -2: 15 pin D Socket Connector, mates with Cannon connector DA-15S or equivalent.

**INPUT VOLTAGE:**  $V_{IN}$  High = +2.0V minimum  
+5.0V typical  
 $V_{CC}$  maximum  
 $V_{IN}$  Low = 0 minimum  
0.8 maximum

**INPUT CURRENT:**  $I_{IN}$  ( $V_{IN}=2.4$  V) = 55  $\mu$ A  
 $I_{IN}$  ( $V_{IN}=3.85$  V) = 280  $\mu$ A

**SUPPLY CURRENT (Digital Section):**  $I_{CC}=25.0$  mA maximum

**SUPPLY CURRENT (per cell continuous):**  $I_{CC}=25.0$  mA maximum for 2 GHz models and 30 mA per cell for 3 GHz models.

**SUPPLY VOLTAGE:**  $V_{CC}=+12.0$  to +15V

**TEMPERATURE RANGE (Operating):** -40°C to +70°C

**MODELS WITH BUILT-IN DRIVERS:** Most 3200s are available with an intelligent interface driver cards. These are designed to interface with our 8210A Series Controllers which greatly simplifies computer control applications. Refer to Model 3200T and 3201T data sheet for more information.

## PHYSICAL DIMENSIONS:

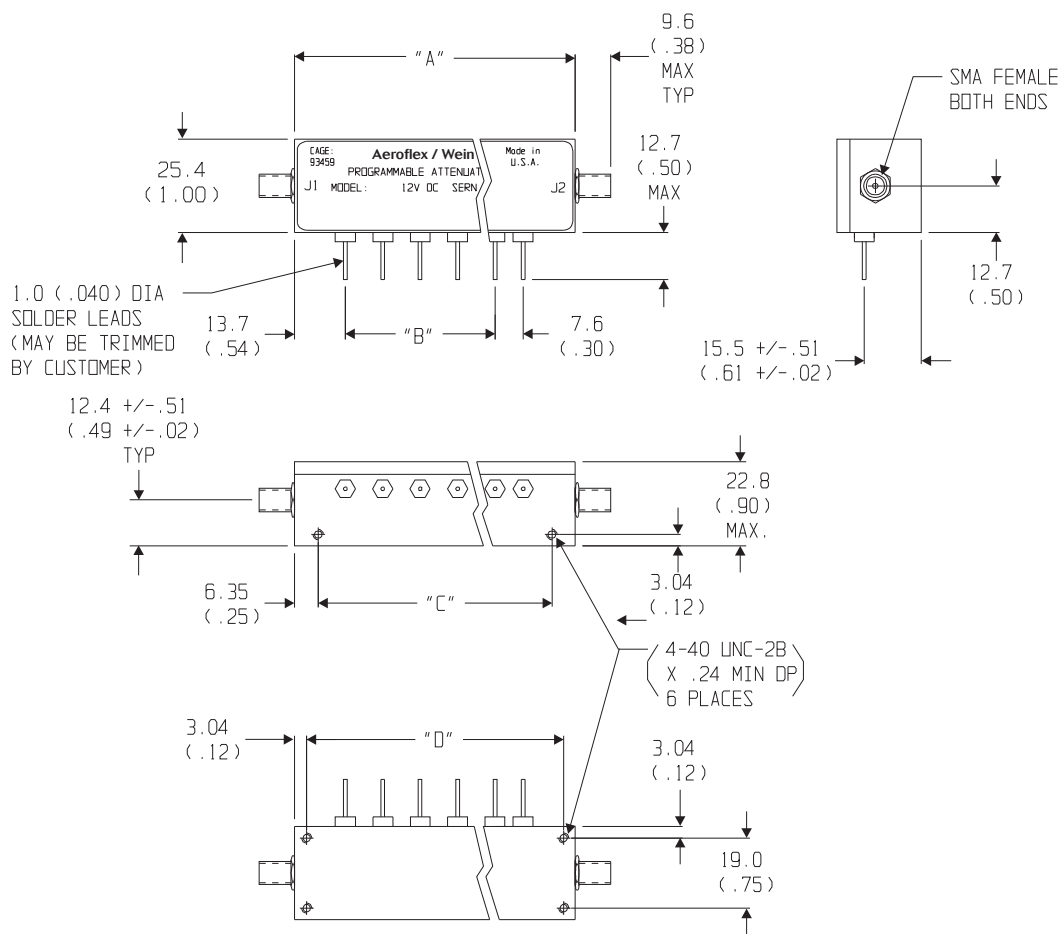

Model No.	No. Cells	A	B	C	D
3200-X	8	101.6 (4.0)	7 EQ SPCS @ 10.16 (.40) = 71.1 (2.80)	88.9 (3.50)	95.2 (3.75)
3201-X	5/4	76.2 (3.00)	4 EQ SPCS @ 10.16 (.40) = 40.64 (1.60)	63.5 (2.50)	69.8 (2.75)
3205-X	4	58.9 (2.32)	3 EQ SPCS @ 10.16 (.40) = 30.5 (1.20)	46.2 (1.82)	52.6 (2.07)
3206-X	6	81.3±0.5 (3.20±0.02)	5 EQ SPCS @ 10.16 (.40) = 50.8 (2.00)	68.6 (2.70)	75.18 (2.96)

NOTE: All dimensions are given in mm (inches) and are maximum, unless otherwise specified.

## PHYSICAL DIMENSIONS:

### TTL OPTION -1 (3200, 3201, 3206):

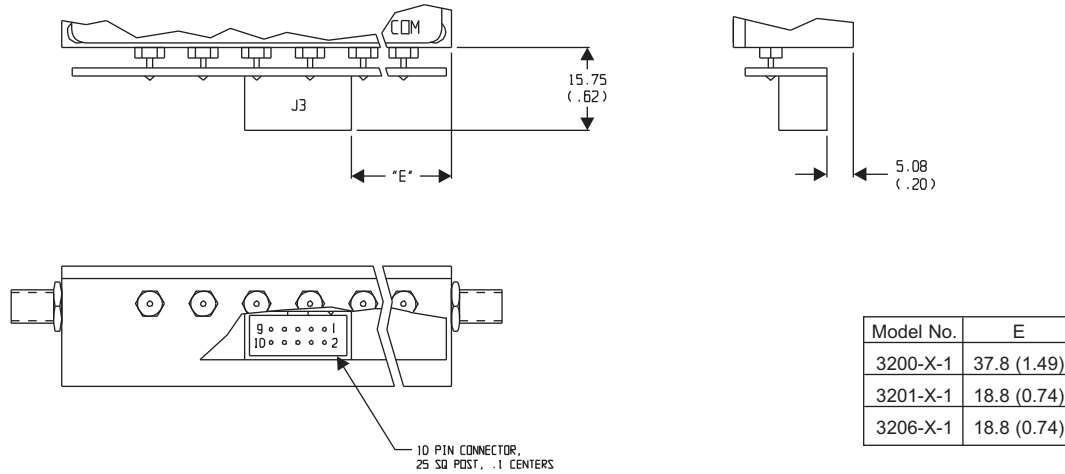

### TTL OPTION -1 (3205):

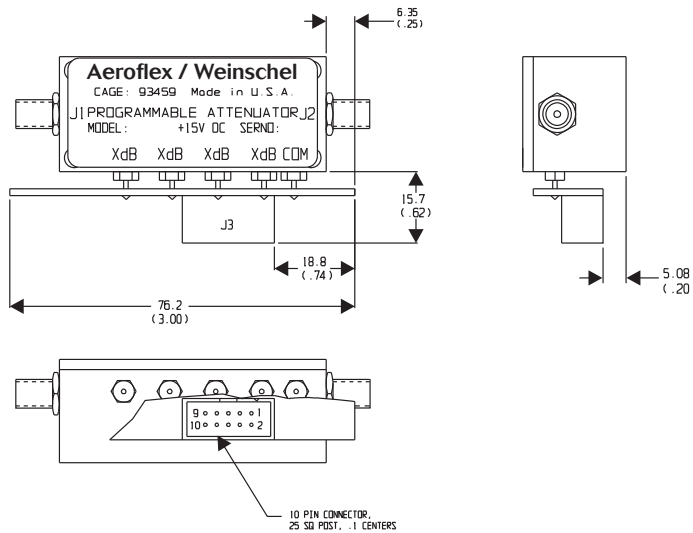

### Control Connector J3 Pin Locations:

TTL Conn PIN No. (J3)	3200-1-1 dB (Cell)	3200-2-1 dB (Cell)	3201-1-1 dB (Cell)	3201-2-1 dB (Cell)	3205-1-1 dB (Cell)	3205-2-1 dB (Cell)	3205-3-1 dB (Cell)	3206-1-1 dB (Cell)
1	32	0.25	NC	NC	NC	NC	NC	NC
2	1	0.5	NC	NC	NC	NC	NC	NC
3	2	1	1	30	NC	NC	NC	1
4	32*	2	2	10	10	5	0.1	2
5	4	4	4	30**	20	10	0.2	4
6	8	8	8	20	20	20	0.4	8
7	16	16	16	30**	20	20	0.8	16
8	32*	32	NC	NC	NC	NC	NC	32
9	COM	COM	COM	COM	COM	COM	COM	COM
10	+Vcc	+Vcc	+Vcc	+Vcc	+Vcc	+Vcc	+Vcc	+Vcc

\*64 dB cell comprised of two 32 dB cells  
 \*\*60 dB cell comprised of two 30 dB cells  
 NC = Not Connected

NOTE: All dimensions are given in mm (inches) and are maximum, unless otherwise specified.

# Programmable Attenuators



## PHYSICAL DIMENSIONS:

### TTL Driver Option -2 (3200, 3201, 3205):

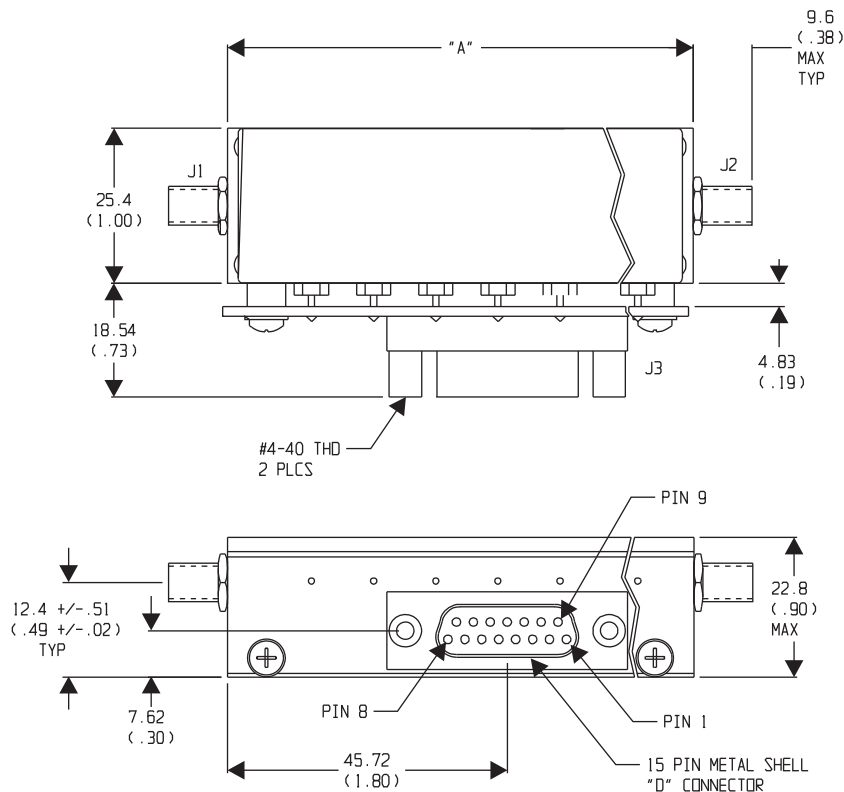

Model No.	A
3200-X-2	101.6 (4.00)
3201-X-2	76.2 (3.00)
3205-X-2	76.2 (3.00)

### Control Connector J3 Pin Locations:

"D" Conn PIN No. (J3)	3200-1-2 dB (Cell)	3200-2-2 dB (Cell)	3201-1-2 dB (Cell)	3201-2-2 dB (Cell)	3205-1-2 dB (Cell)	3205-2-2 dB (Cell)	3205-3-2 dB (Cell)	Cable (P/N 101-1805) Color Code
1	32	32	NC	NC	NC	NC	NC	BRN
2	16	16	NC	NC	NC	NC	NC	YEL
3	8	8	NC	NC	NC	NC	NC	GRN
4	4	4	16	30**	20	20	0.8	LT BLU
5	32	0.25	1	30**	NC	NC	NC	VIO
6	1	0.5	2	10	10	5	0.1	GRY
7	2	1	4	30	20	10	0.2	WHT
8	32*	2	8	20	20	20	0.4	WHT/BLK
9	NC	NC	NC	NC	NC	NC	NC	RED
10	GND	GND	GND	GND	GND	GND	GND	BLK
11	NC	NC	NC	NC	NC	NC	NC	---
12	NC	NC	NC	NC	NC	NC	NC	---
13	NC	NC	NC	NC	NC	NC	NC	---
14	NC	NC	NC	NC	NC	NC	NC	---
15	+Vcc	+Vcc	+Vcc	+Vcc	+Vcc	+Vcc	+Vcc	ORN

\*64 dB cell comprised of two 32 dB cells  
 \*\*60 dB cell comprised of two 30 dB cells  
 NC = Not Connected

NOTE: All dimensions are given in mm (inches) and are maximum, unless otherwise specified.

**PHYSICAL DIMENSIONS:**

**Model 3209-1:**

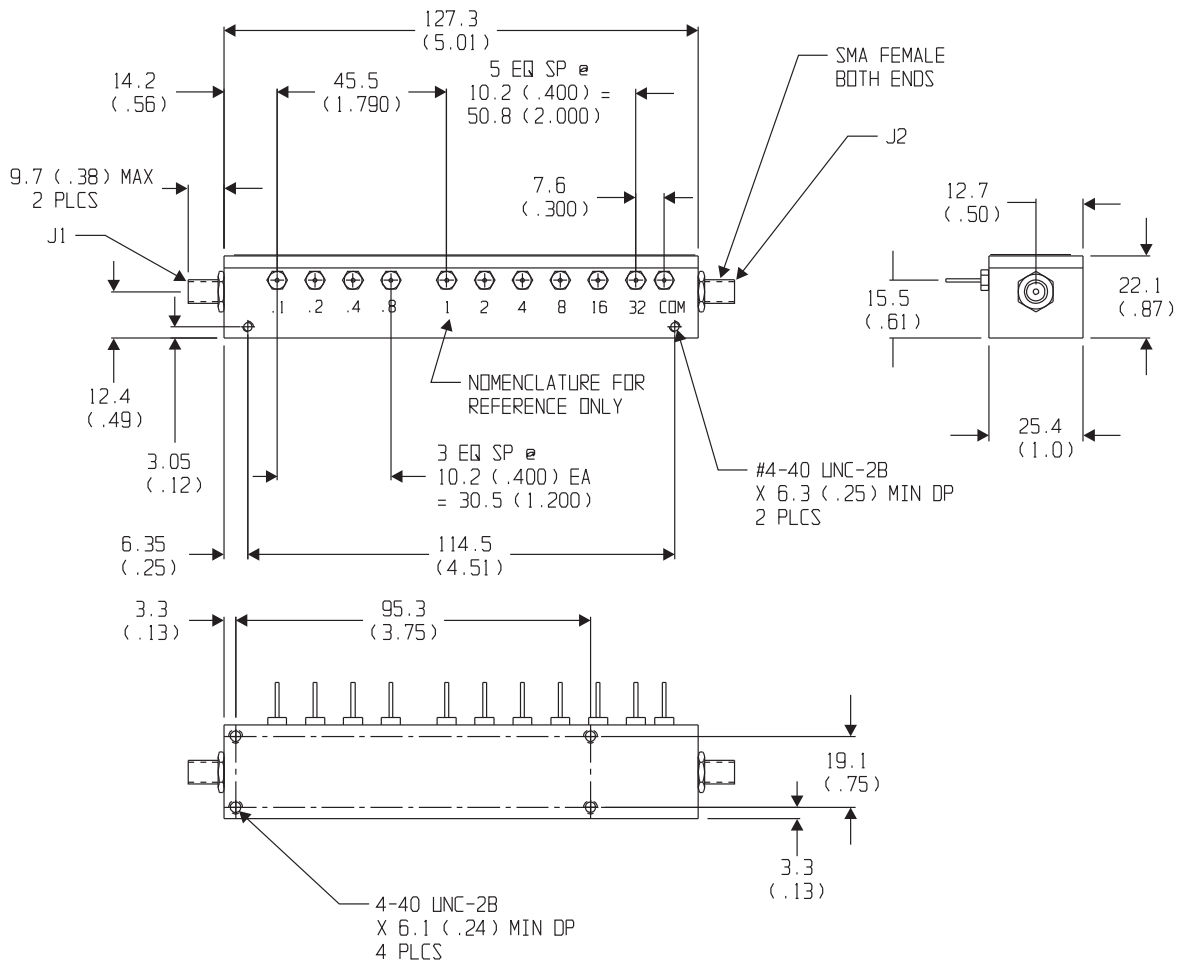

**Model 3209-1-1 (TTL Option -1):**

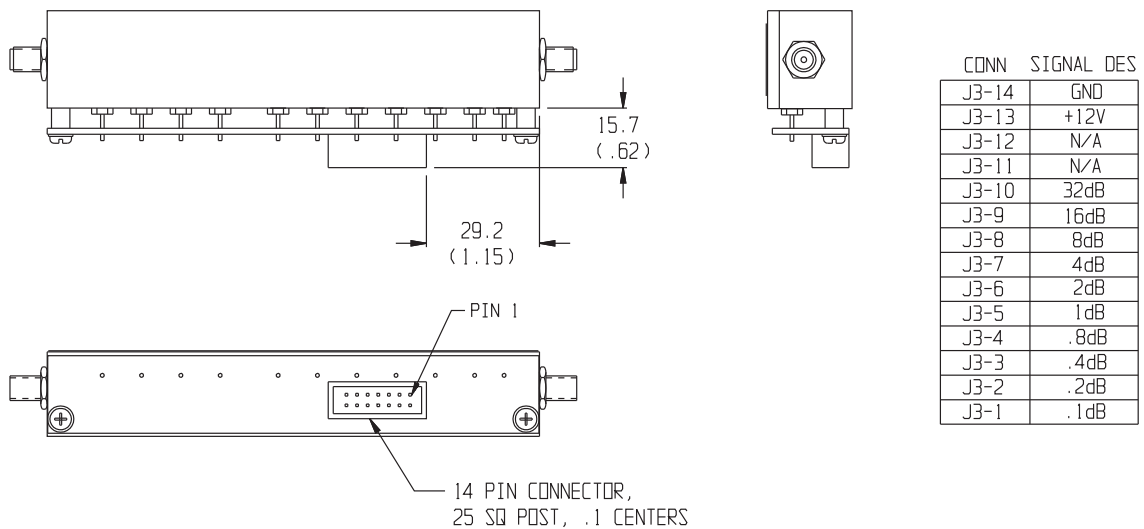

NOTE: All dimensions are given in mm (inches) and are maximum, unless otherwise specified.