

### FEATURES

- Tight Output Voltage Tolerance
- Low Output Noise
- Operating Current 250 $\mu$ A to 100mA
- Low Dynamic Impedance
- Low Temperature Coefficient
- Available in the sub-miniature SOT-23 Package
- 1.2V Device ( AMS4041) also available

### APPLICATIONS

- Battery Powered Systems
- Instrumentation
- Energy Management
- Automotive
- Precision Audio Components
- Product Testing
- Data Acquisition Systems

### GENERAL DESCRIPTION

The AMS4040 is a two-terminal micropower band-gap voltage reference diode featuring a very low dynamic impedance and good temperature coefficient, operating over a 250 $\mu$ A to 100mA current range. On-chip trimming is used to provide tight voltage tolerance. Since the AMS4040 band-gap reference uses only transistors and resistors, low noise and good long term stability result. The wide dynamic operating range allows its use with widely varying supplies with excellent regulation. The extremely low power drain of the AMS4040 makes these reference diodes useful for micropower circuitry. These voltage references can be used to make portable meters, regulators or general purpose analog circuitry with battery life approaching shelf life.

The AMS4040 is operational in the full industrial temperature range of -40°C to +85°and is available in small space saving TO-92, SO-8, SOT-89 and SOT-23 packages.

### ORDERING INFORMATION:

TOL.	PACKAGE TYPE				OPERATING TEMP. RANGE
	TO-92	8 LEAD SOIC	SOT-89	3 LEAD SOT-23	
±0.25%	AMS4040AN	AMS4040AS	AMS4040AL	AMS4040AM	-40 to +85° C
±0.5%	AMS4040BN	AMS4040BS	AMS4040BL	AMS4040BM	-40 to +85° C
±1.0%	AMS4040CN	AMS4040CS	AMS4040CL	AMS4040CM	-40 to +85° C

### PIN CONNECTIONS

**TO-92**  
Plastic Package (N)

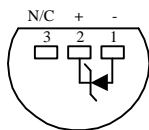

**Bottom View**

**8L SOIC**  
SO Package (S)

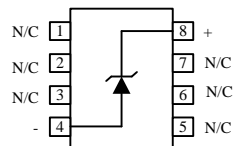

**Top View**

**SOT-89**  
(L)

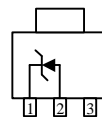

**Top View**

**3L SOT-23**  
(M)

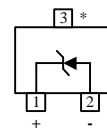

**Top View**

\*This pin must be left floating or connected to pin 2

## ABSOLUTE MAXIMUM RATINGS (Note 1)

Reverse Current	100mA	Internal Power Dissipation ( $P_D$ )	
Forward Current	10mA	TO-92 Package	0.78W
Storage temperature	-65°C to +150°C	SO-8 Package	0.71W
Lead Temperature		SOT-89 Package	0.91W
TO-92 package (Soldering 10 sec.)	265°C	SOT-23 Package	0.28W
SO-8 and SOT-23 packages:		Thermal Resistance ( $\theta_{JA}$ )	
Vapor phase (60 sec)	215°C	TO-92 Package	160°C/W
Infrared (15 sec.)	220°C	SO-8 Package	175°C/W
SOT-89 package (Soldering 10 sec.)	265°C	SOT-89 Package	110°C/W
		SOT-23 Package	410°C/W

**Note1:** Absolute Maximum Ratings indicate limits beyond which damage to the device may occur. For guaranteed specifications and test conditions, see the Electrical Characteristics. The guaranteed specifications apply only for the test conditions listed.

## ELECTRICAL CHARACTERISTICS

Electrical Characteristics at  $I_R = 100 \mu A$  and  $T_A = +25^\circ C$  unless otherwise specified.

Parameter	Conditions	AMS4040A			AMS4040B			AMS4040C			Units
		Min	Typ	Max	Min	Typ	Max	Min	Typ	Max	
Reverse Breakdown Voltage		2.494	2.500	2.506	2.488	2.500	2.512	2.475	2.500	2.525	V
Deviation of Reverse Breakdown Voltage over Temperature	$T_A = \text{Full Range}$		8.0	17		8.0	17		8.0	25	mV
Reverse Breakdown Voltage Change with Operating Current Change	$I_{RMIN} \leq I_R \leq 1mA$		0.3	0.8		0.3	0.8		0.3	0.8	mV
	$1mA \leq I_R \leq 15mA$		2.5	6.0		2.5	6.0		2.5	6.0	mV
Reverse Breakdown Voltage Long Term Stability	$T_A = 25^\circ C \pm 1^\circ C$ $T = 1000 \text{ Hr}$		120			120			120		ppm
Wide Band Noise	$10\text{HZ} \leq f \leq 10\text{kHz}$		35			35			35		$\mu V_{rms}$
Reverse Dynamic Impedance	$I_R = 1mA, f = 120\text{Hz},$ $I_{AC} = 0.1I_R$		0.25	0.5		0.25	0.5		0.25	0.5	$\Omega$
Minimum Operating Current			80	2500		80	250		80	250	$\mu A$

Parameters identified with **boldface type** apply at temperature extremes. All other numbers apply at  $T_A = T_J = 25^\circ C$ .

## TYPICAL APPLICATIONS

### Shunt Regulator

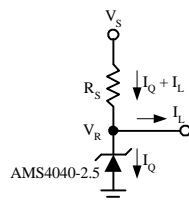

## TYPICAL APPLICATIONS

### Precision 1 $\mu$ A to 1mA Current Sources

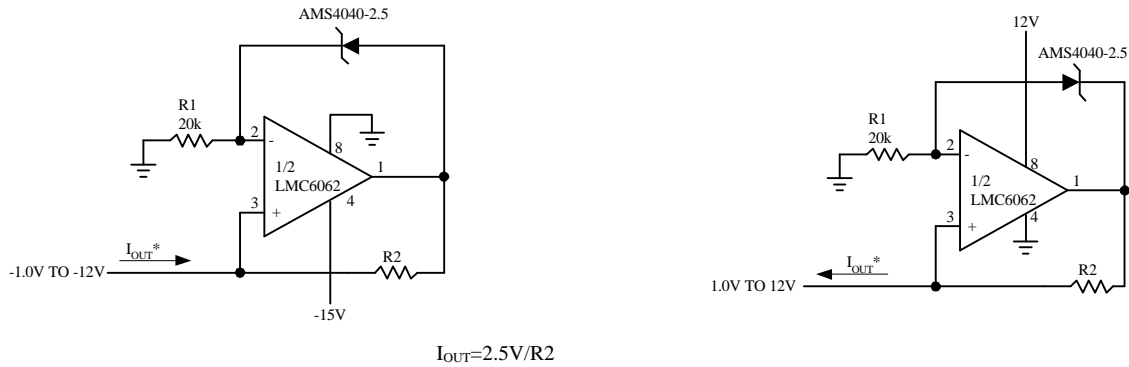

### Precision $\pm 2.500V$ Reference

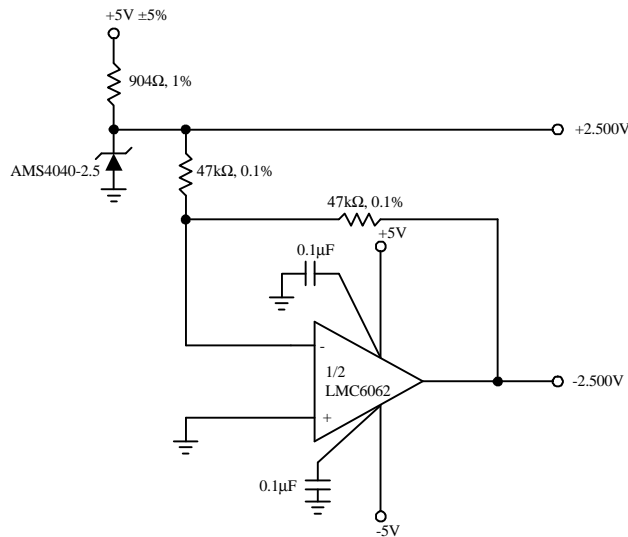

## START-UP CHARACTERISTICS

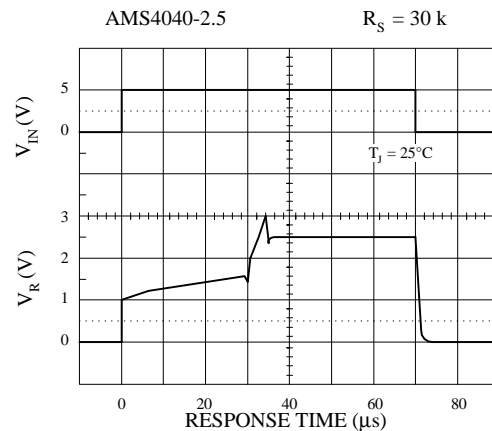
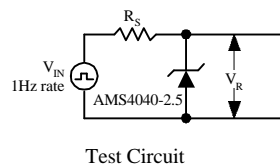

## TYPICAL PERFORMANCE CHARACTERISTICS

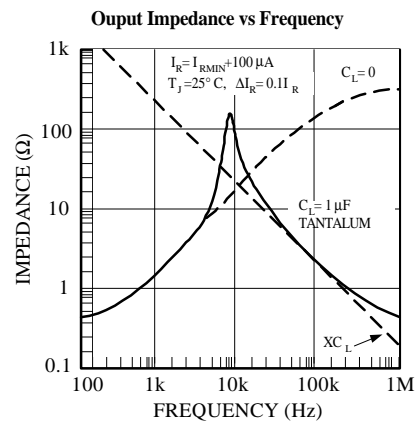
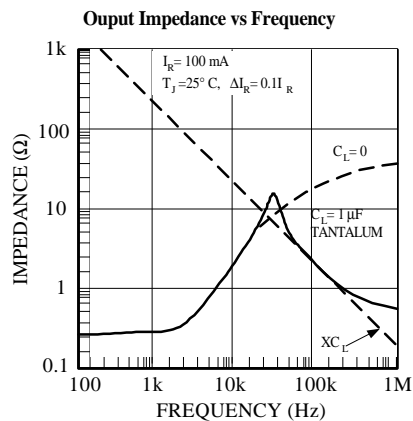
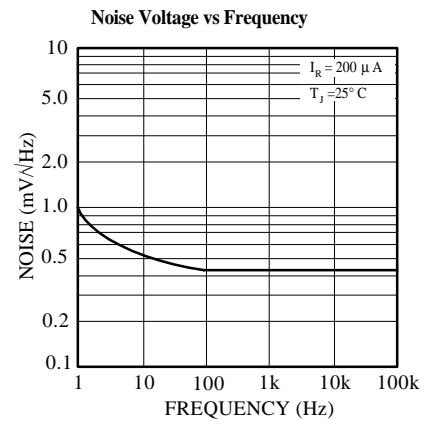
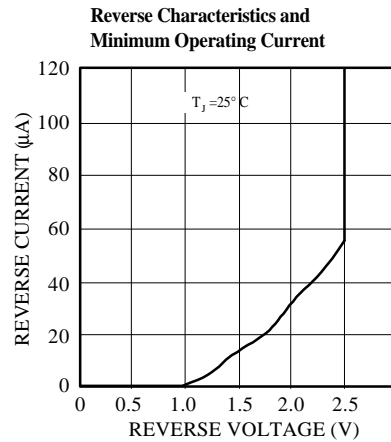
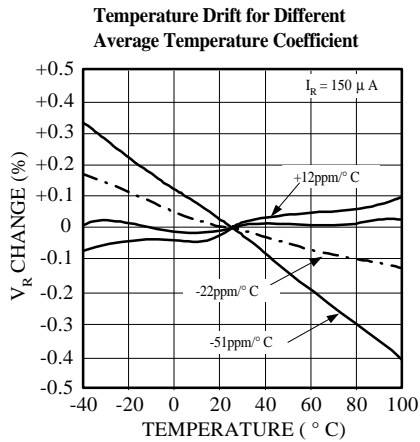

PACKAGE DIMENSIONS inches (millimeters) unless otherwise noted.

## 3 LEAD TO-92 PLASTIC PACKAGE (N)

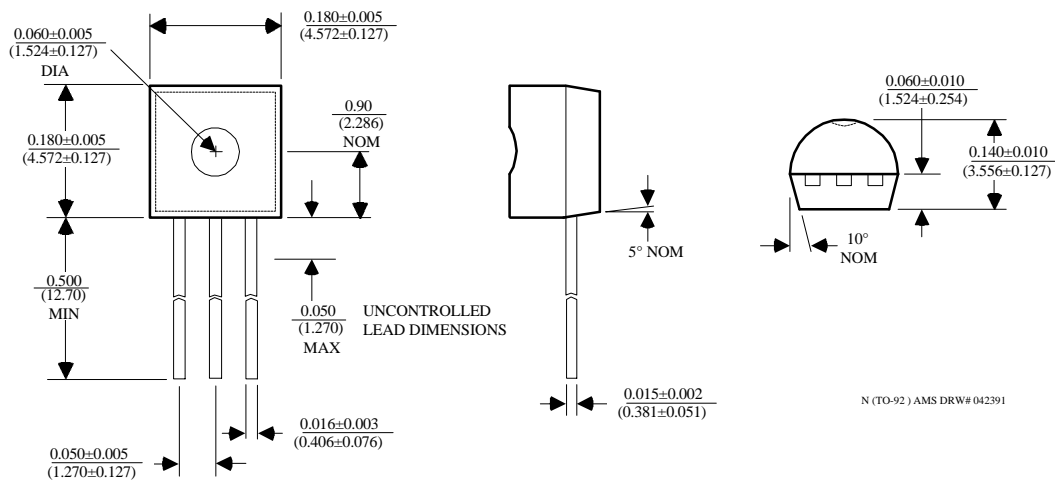

## 8 LEAD SOIC PLASTIC PACKAGE (S)

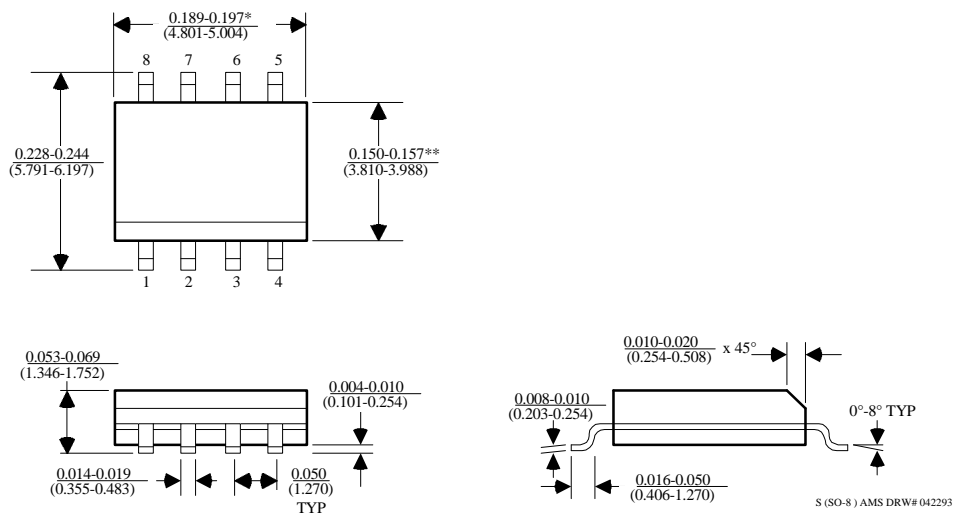

PACKAGE DIMENSIONS inches (millimeters) unless otherwise noted (Continued).

## SOT-89 PLASTIC PACKAGE (L)

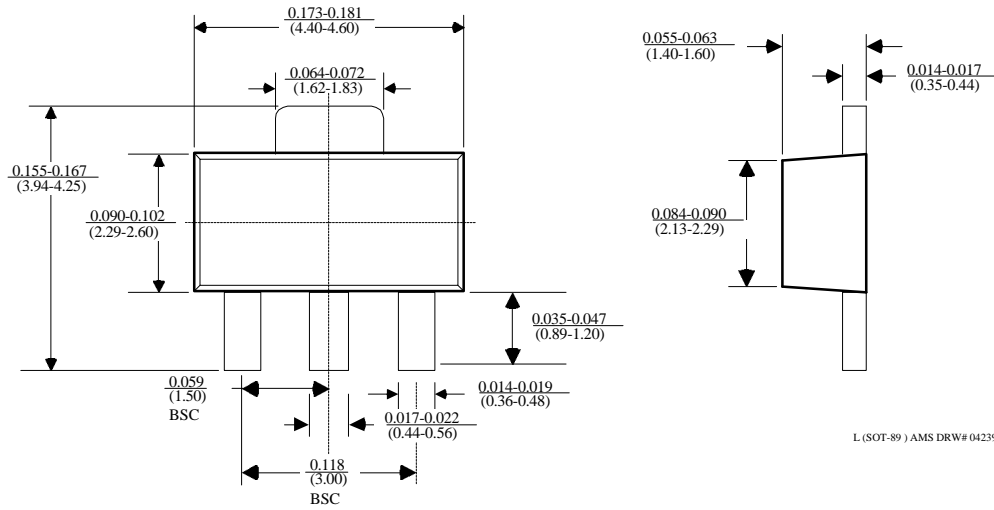

## 3 LEAD SOT-23 PLASTIC PACKAGE (M)

