

Am29LV320D

Data Sheet



July 2003

The following document specifies Spansion memory products that are now offered by both Advanced Micro Devices and Fujitsu. Although the document is marked with the name of the company that originally developed the specification, these products will be offered to customers of both AMD and Fujitsu.

Continuity of Specifications

There is no change to this datasheet as a result of offering the device as a Spansion product. Any changes that have been made are the result of normal datasheet improvement and are noted in the document revision summary, where supported. Future routine revisions will occur when appropriate, and changes will be noted in a revision summary.

Continuity of Ordering Part Numbers

AMD and Fujitsu continue to support existing part numbers beginning with "Am" and "MBM". To order these products, please use only the Ordering Part Numbers listed in this document.

For More Information

Please contact your local AMD or Fujitsu sales office for additional information about Spansion memory solutions.

Publication Number **23579** Revision **C** Amendment **+6** Issue Date **November 15, 2004**



THIS PAGE LEFT INTENTIONALLY BLANK.



Am29LV320D

32 Megabit (4 M x 8-Bit/2 M x 16-Bit)

CMOS 3.0 Volt-only, Boot Sector Flash Memory

DISTINCTIVE CHARACTERISTICS

ARCHITECTURAL ADVANTAGES

- **Secured Silicon (SecSi™ Sector)**
 - 64 Kbyte Sector Size; Replacement/substitute devices (such as Mirrorbit™) have 256 bytes.
 - *Factory locked and identifiable*: 16 bytes (8 words) available for secure, random factory Electronic Serial Number; verifiable as factory locked through autoselect function. ExpressFlash option allows entire sector to be available for factory-secured data
 - *Customer lockable*: Can be programmed once and then permanently locked after being shipped from AMD
- **Zero Power Operation**
 - Sophisticated power management circuits reduce power consumed during inactive periods to nearly zero.
- **Package options**
 - 48-pin TSOP
 - 48-ball FBGA
- **Sector Architecture**
 - Eight 8 Kbyte sectors
 - Sixty-three 64 Kbyte sectors
- **Top or bottom boot block**
- **Manufactured on 0.23 μm process technology**
- **Compatible with JEDEC standards**
 - Pinout and software compatible with single-power-supply flash standard

PERFORMANCE CHARACTERISTICS

- **High performance**
 - Access time as fast 90 ns
 - Program time: 7μs/word typical utilizing Accelerate function
- **Ultra low power consumption (typical values)**
 - 2 mA active read current at 1 MHz
 - 10 mA active read current at 5 MHz
 - 200 nA in standby or automatic sleep mode

- **Minimum 1 million erase cycles guaranteed per sector**
- **20 Year data retention at 125°C**
 - Reliable operation for the life of the system

SOFTWARE FEATURES

- **Supports Common Flash Memory Interface (CFI)**
- **Erase Suspend/Erase Resume**
 - Suspends erase operations to allow programming in non-suspended sectors
- **Data# Polling and Toggle Bits**
 - Provides a software method of detecting the status of program or erase cycles
- **Unlock Bypass Program command**
 - Reduces overall programming time when issuing multiple program command sequences

HARDWARE FEATURES

- **Any combination of sectors can be erased**
- **Ready/Busy# output (RY/BY#)**
 - Hardware method for detecting program or erase cycle completion
- **Hardware reset pin (RESET#)**
 - Hardware method of resetting the internal state machine to the read mode
- **WP#/ACC input pin**
 - Write protect (WP#) function allows protection of two outermost boot sectors, regardless of sector protect status
 - Acceleration (ACC) function provides accelerated program times
- **Sector protection**
 - Hardware method of locking a sector, either in-system or using programming equipment, to prevent any program or erase operation within that sector
 - Temporary Sector Unprotect allows changing data in protected sectors in-system

GENERAL DESCRIPTION

The Am29LV320D is a 32 megabit, 3.0 volt-only flash memory device, organized as 2,097,152 words of 16 bits each or 4,194,304 bytes of 8 bits each. Word mode data appears on DQ0–DQ15; byte mode data appears on DQ0–DQ7. The device is designed to be programmed in-system with the standard 3.0 volt V_{CC} supply, and can also be programmed in standard EPROM programmers.

The device is available with an access time of 90 or 120 ns. The devices are offered in 48-pin TSOP and 48-ball FBGA packages. Standard control pins—chip enable (CE#), write enable (WE#), and output enable (OE#)—control normal read and write operations, and avoid bus contention issues.

The device requires only a **single 3.0 volt power supply** for both read and write functions. Internally generated and regulated voltages are provided for the program and erase operations.

Am29LV320D Features

The **SecSi™ Sector (Secured Silicon)** is an extra sector capable of being permanently locked by AMD or customers. The **SecSi Indicator Bit** (DQ7) is permanently set to a 1 if the part is **factory locked**, and set to a 0 if **customer lockable**. This way, customer lockable parts can never be used to replace a factory locked part. **Note that the Am29LV320D has a SecSi Sector size of 64 Kbytes. AMD devices designated as replacements or substitutes, such as the Am29LV320M, have 256 bytes. This should be considered during system design.**

Factory locked parts provide several options. The SecSi Sector may store a secure, random 16 byte ESN (Electronic Serial Number), cus-

tomers code (programmed through AMD's ExpressFlash service), or both. Customer Lockable parts may utilize the SecSi Sector as bonus space, reading and writing like any other flash sector, or may permanently lock their own code there.

The device offers complete compatibility with the **JEDEC single-power-supply Flash command set standard**. Commands are written to the command register using standard microprocessor write timings. Reading data out of the device is similar to reading from other Flash or EPROM devices.

The host system can detect whether a program or erase operation is complete by using the device **status bits**: RY/BY# pin, DQ7 (Data# Polling) and DQ6/DQ2 (toggle bits). After a program or erase cycle is completed, the device automatically returns to the read mode.

The **sector erase architecture** allows memory sectors to be erased and reprogrammed without affecting the data contents of other sectors. The device is fully erased when shipped from the factory.

Hardware data protection measures include a low V_{CC} detector that automatically inhibits write operations during power transitions. The **hardware sector protection** feature disables both program and erase operations in any combination of the sectors of memory. This can be achieved in-system or via programming equipment.

The device offers two power-saving features. When addresses are stable for a specified amount of time, the device enters the **automatic sleep mode**. The system can also place the device into the **standby mode**. Power consumption is greatly reduced in both modes.

TABLE OF CONTENTS

Product Selector Guide	6	Figure 4. Program Operation	27
Block Diagram	6	Chip Erase Command Sequence	27
Connection Diagrams	7	Sector Erase Command Sequence	27
Special Package Handling Instructions	8	Erase Suspend/Erase Resume Commands	28
Pin Description	9	Figure 5. Erase Operation	28
Logic Symbol	9	Command Definitions	29
Ordering Information	10	Table 14. Am29LV320D Command Definitions	29
Device Bus Operations	11	Write Operation Status	30
Table 1. Am29LV320D Device Bus Operations	11	DQ7: Data# Polling	30
Word/Byte Configuration	11	Figure 6. Data# Polling Algorithm	30
Requirements for Reading Array Data	11	RY/BY#: Ready/Busy#	31
Writing Commands/Command Sequences	12	DQ6: Toggle Bit I	31
Accelerated Program Operation	12	Figure 7. Toggle Bit Algorithm.....	31
Autoselect Functions	12	DQ2: Toggle Bit II	32
Standby Mode	12	Reading Toggle Bits DQ6/DQ2	32
Automatic Sleep Mode	13	DQ5: Exceeded Timing Limits	32
RESET#: Hardware Reset Pin	13	DQ3: Sector Erase Timer	32
Output Disable Mode	13	Table 15. Write Operation Status	33
Table 2. Top Boot Sector Addresses (Am29LV320DT)	13	Absolute Maximum Ratings	34
Table 3. Top Boot SecSi™ Sector Addresses.....	14	Figure 8. Maximum Negative Overshoot Waveform	34
Table 4. Bottom Boot Sector Addresses (Am29LV320DB)	15	Figure 9. Maximum Positive Overshoot Waveform.....	34
Table 5. Bottom Boot SecSi™ Sector Addresses	16	Operating Ranges	34
Autoselect Mode	16	DC Characteristics	35
Table 6. Autoselect Codes (High Voltage Method)	16	Figure 10. I _{CC1} Current vs. Time (Showing Active and	
Sector/Sector Block Protection and Unprotection	17	Automatic Sleep Currents).....	36
Table 7. Top Boot Sector/Sector Block Addresses		Figure 11. Typical I _{CC1} vs. Frequency.....	36
for Protection/Unprotection	17	Test Conditions	37
Table 8. Bottom Boot Sector/Sector Block		Figure 12. Test Setup.....	37
Addresses for Protection/Unprotection	17	Table 16. Test Specifications	37
Write Protect (WP#)	18	Figure 13. Input Waveforms and Measurement Levels	37
Temporary Sector Unprotect	18	AC Characteristics	38
Figure 1. Temporary Sector Unprotect Operation.....	18	Figure 14. Read Operation Timings	38
Figure 2. In-System Sector Protect/Unprotect Algorithms	19	Figure 15. Reset Timings	39
SecSi™ Sector (Secured Silicon) Flash Memory Region	20	Word/Byte Configuration (BYTE#)	40
Factory Locked: SecSi Sector Programmed		Figure 16. BYTE# Timings for Read Operations.....	40
and Protected at the Factory	20	Figure 17. BYTE# Timings for Write Operations.....	40
Customer Lockable: SecSi Sector NOT Programmed		Erase and Program Operations	41
or Protected at the Factory	20	Figure 18. Program Operation Timings.....	42
Figure 3. SecSi Sector Protect Verify.....	21	Figure 19. Chip/Sector Erase Operation Timings	43
Hardware Data Protection	21	Figure 20. Data# Polling Timings (During Embedded Algorithms).....	44
Low VCC Write Inhibit	21	Figure 21. Toggle Bit Timings (During Embedded Algorithms).....	45
Write Pulse “Glitch” Protection	21	Figure 22. DQ2 vs. DQ6.....	45
Logical Inhibit	21	Temporary Sector Unprotect	46
Power-Up Write Inhibit	21	Figure 23. Temporary Sector Unprotect Timing Diagram	46
Common Flash Memory Interface (CFI)	21	Figure 24. Accelerated Program Timing Diagram	46
Table 9. CFI Query Identification String	22	Figure 25. Sector/Sector Block Protect and	
Table 10. System Interface String.....	22	Unprotect Timing Diagram	47
Table 11. Device Geometry Definition	23	Alternate CE# Controlled Erase and Program Operations	48
Table 12. Primary Vendor-Specific Extended Query	24	Figure 26. Alternate CE# Controlled Write	
Command Definitions	25	(Erase/Program) Operation Timings	49
Reading Array Data	25	Erase And Programming Performance	50
Reset Command	25	Latchup Characteristics	50
Autoselect Command Sequence	25	TSOP and BGA Package Capacitance	50
Table 13. Autoselect Codes	25	Data Retention	50
Enter SecSi™ Sector/Exit SecSi Sector		Physical Dimensions	51
Command Sequence	26	FBD048—48-ball Fine-Pitch Ball Grid Array (FBGA)	
Byte/Word Program Command Sequence	26	6 x 12 mm package	51
Unlock Bypass Command Sequence	26	TS 048—48-Pin Standard TSOP	52
		Revision Summary	53

PRODUCT SELECTOR GUIDE

Family Part Number		Am29LV320D	
Speed Option	Standard Voltage Range: $V_{CC} = 2.7-3.6\text{ V}$ 90R Standard Voltage Range: $V_{CC} = 3.0-3.6\text{ V}$	90	120
Max Access Time (ns)		90	120
CE# Access (ns)		90	120
OE# Access (ns)		40	50

BLOCK DIAGRAM

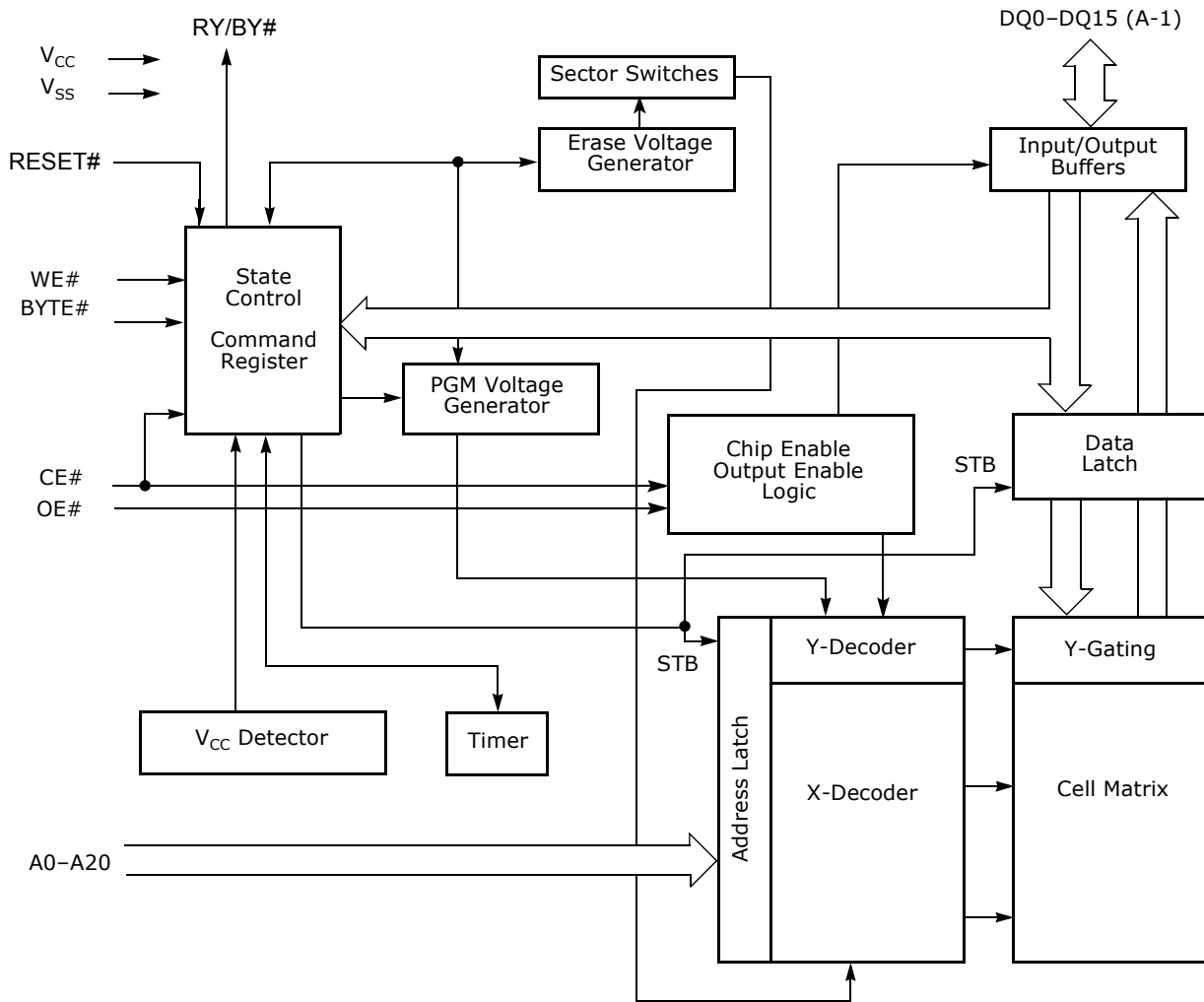

CONNECTION DIAGRAMS

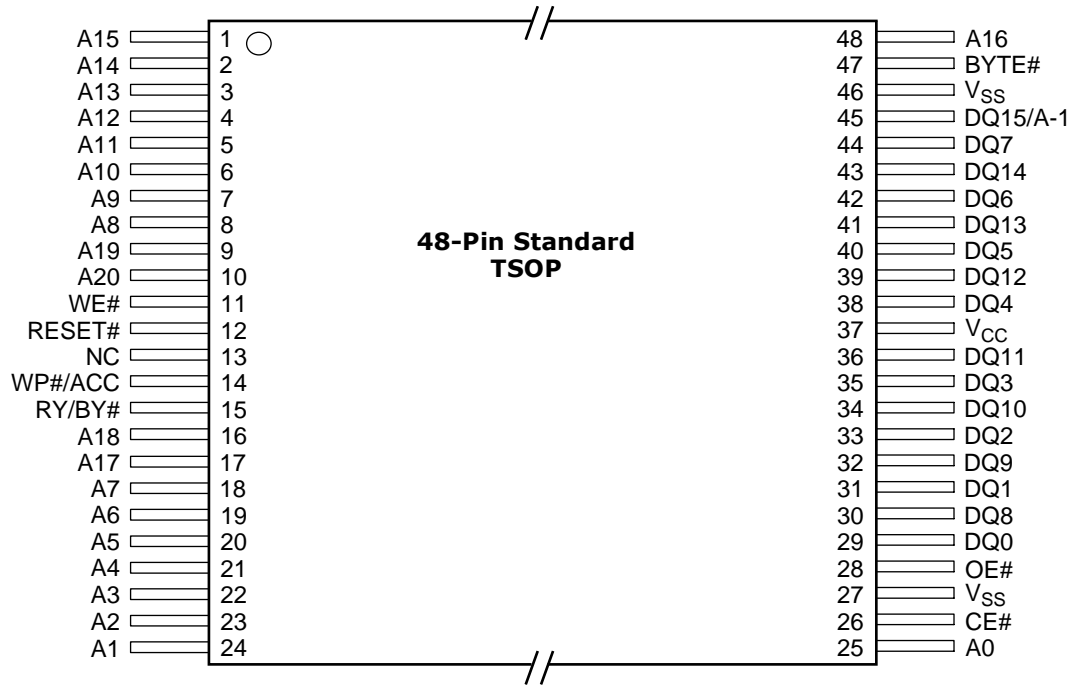

CONNECTION DIAGRAMS

48-Ball FBGA
Top View, Balls Facing Down

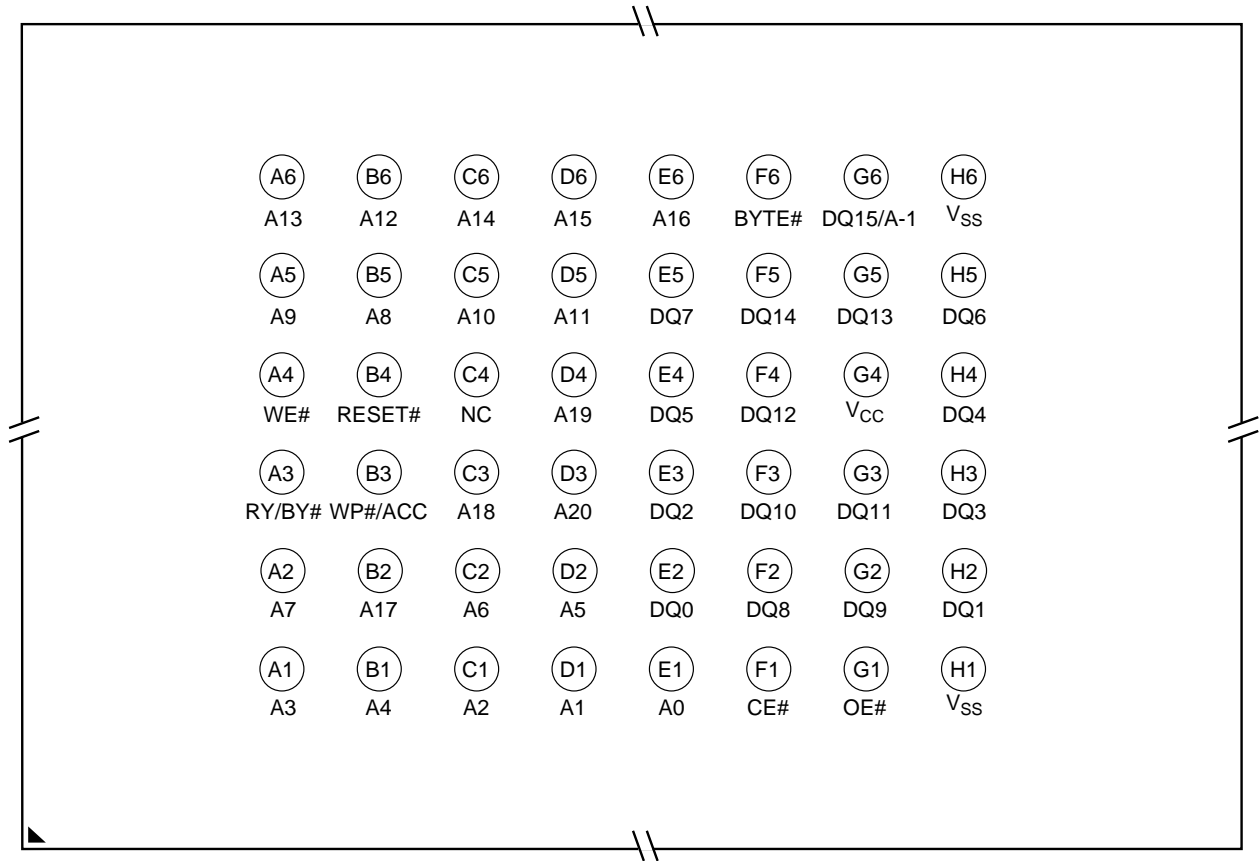

Special Package Handling Instructions

Special handling is required for Flash Memory products in molded (TSOP, BGA) packages.

The package and/or data integrity may be compromised if the package body is exposed to temperatures above 150°C for prolonged periods of time.

PIN DESCRIPTION

A0–A20	= 21 Addresses
DQ0–DQ14	= 15 Data Inputs/Outputs
DQ15/A-1	= DQ15 (Data Input/Output, word mode), A-1 (LSB Address Input, byte mode)
CE#	= Chip Enable
OE#	= Output Enable
WE#	= Write Enable
WP#/ACC	= Hardware Write Protect/ Acceleration Pin
RESET#	= Hardware Reset Pin, Active Low
BYTE#	= Selects 8-bit or 16-bit mode
RY/BY#	= Ready/Busy Output
V _{CC}	= 3.0 volt-only single power supply (see Product Selector Guide for speed options and voltage supply toler- ances)
V _{SS}	= Device Ground
NC	= Pin Not Connected Internally

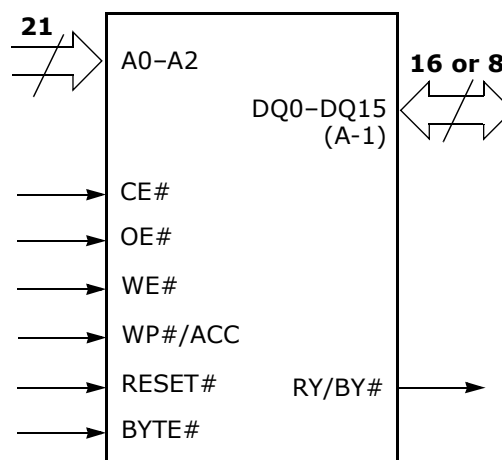
LOGIC SYMBOL

ORDERING INFORMATION

Standard Products

AMD standard products are available in several packages and operating ranges. The order number (Valid Combination) is formed by a combination of the following:

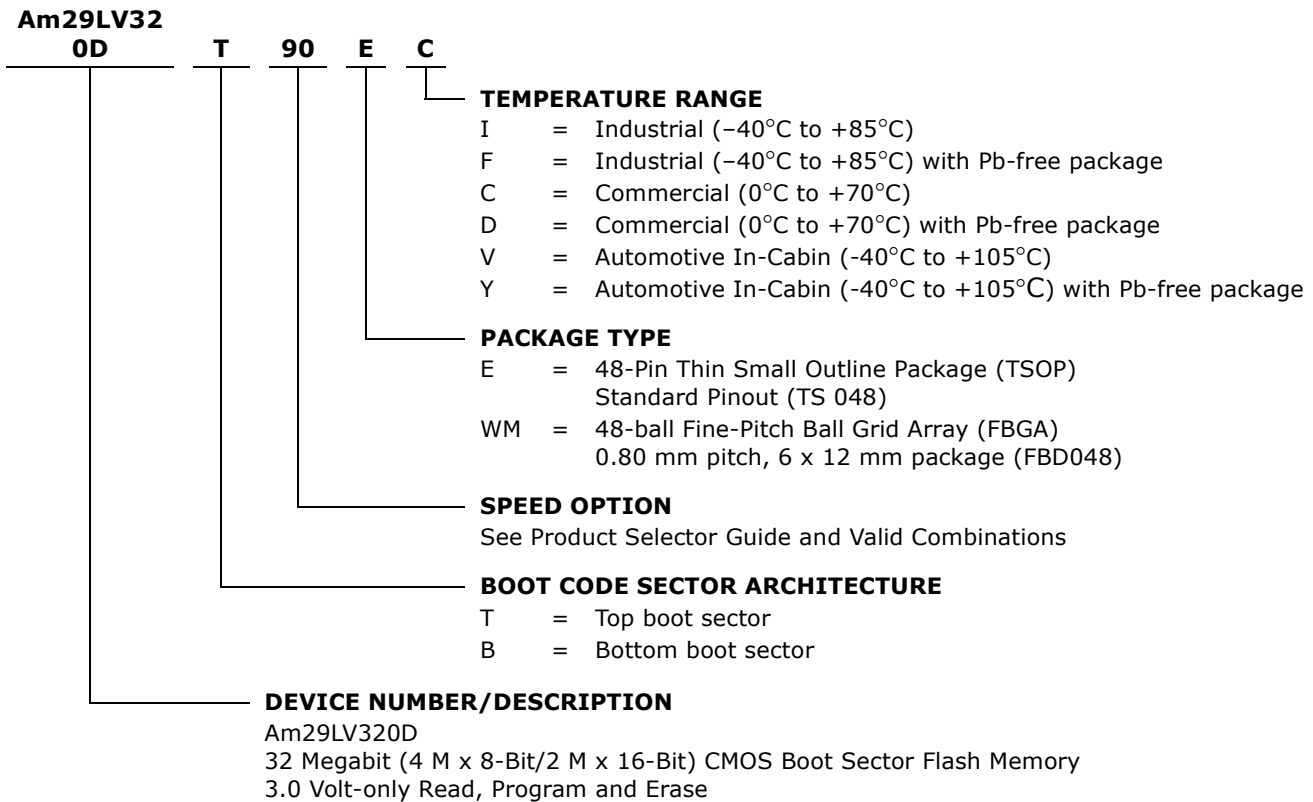

Valid Combinations for TSOP Packages	Speed (Ns)	V _{CC} Range
AM29LV320DT90R, AM29LV320DB90R	90	3.0– 3.6V
Am29LV320DT90, Am29LV320DB90	90	2.7– 3.6V
AM29LV320DT120, AM29LV320DB120	120	2.7– 3.6V
Am29LV320DT120 Am29LV320DB120	120	2.7 – 3,6V

Valid Combinations for FBGA Packages			
Order Number		Package Marking	
AM29LV320DT90, AM29LV320DB90	WMC,W MI,	L320DT90V, L320DB90V	C, I, D, F
AM29LV320DT120, AM29LV320DB120	WMD, WMF	L320DT12V, L320DB12V	
Am29LV320DT120 Am29LV320DB120	WNV	L320DT12V L320DB12V	V, Y

Valid Combinations

Valid Combinations list configurations planned to be supported in volume for this device. Consult the local AMD sales office to confirm availability of specific valid combinations and to check on newly released combinations.

DEVICE BUS OPERATIONS

This section describes the requirements and use of the device bus operations, which are initiated through the internal command register. The command register itself does not occupy any addressable memory location. The register is a latch used to store the commands, along with the address and data information needed to execute the command. The contents of the

register serve as inputs to the internal state machine. The state machine outputs dictate the function of the device. [Table 1](#) lists the device bus operations, the inputs and control levels they require, and the resulting output. The following subsections describe each of these operations in further detail.

Table 1. Am29LV320D Device Bus Operations

Operation	CE#	OE#	WE #	RESET #	WP#/ACC	Addresses (Note 2)	DQ0–DQ7	DQ8–DQ15	
								BYTE # = V _{IH}	BYTE# = V _{IL}
Read	L	L	H	H	L/H	A _{IN}	D _{OUT}	D _{OUT}	DQ8–DQ14 = High-Z, DQ15 = A-1
Write	L	H	L	H	(Note 3)	A _{IN}	(Note 4)	(Note 4)	
Accelerated Program	L	H	L	H	V _{HH}	A _{IN}	(Note 4)	(Note 4)	
Standby	V _{CC} ± 0.3 V	X	X	V _{CC} ± 0.3 V	H	X	High-Z	High-Z	High-Z
Output Disable	L	H	H	H	L/H	X	High-Z	High-Z	High-Z
Reset	X	X	X	L	L/H	X	High-Z	High-Z	High-Z
Sector Protect (Note 2)	L	H	L	V _{ID}	L/H	SA, A6 = L, A1 = H, A0 = L	(Note 4)	X	X
Sector Unprotect (Note 2)	L	H	L	V _{ID}	(Note 3)	SA, A6 = H, A1 = H, A0 = L	(Note 4)	X	X
Temporary Sector Unprotect	X	X	X	V _{ID}	(Note 3)	A _{IN}	(Note 4)	(Note 4)	High-Z

Legend: L = Logic Low = V_{IL}, H = Logic High = V_{IH}, V_{ID} = 11.5–12.5 V, V_{HH} = 11.5–12.5 V, X = Don't Care, SA = Sector Address, A_{IN} = Address In, D_{IN} = Data In, D_{OUT} = Data Out

Notes:

- Addresses are A20:A0 in word mode (BYTE# = V_{IH}), A20:A-1 in byte mode (BYTE# = V_{IL}).
- The sector protect and sector unprotect functions may also be implemented via programming equipment. See ["Sector/Sector Block Protection and Unprotection"](#) on page 17.
- If WP#/ACC = V_{IL}, the two outermost boot sectors remain protected. If WP#/ACC = V_{IH}, the two outermost boot sector protection depends on whether they were last protected or unprotected using the method described in ["Sector/Sector Block Protection and Unprotection"](#) on page 17. If WP#/ACC = V_{HH}, all sectors are unprotected.
- D_{IN} or D_{OUT} as required by command sequence, data polling, or sector protection algorithm.

Word/Byte Configuration

The BYTE# pin controls whether the device data I/O pins operate in the byte or word configuration. If the BYTE# pin is set at logic '1', the device is in word configuration, DQ0–DQ15 are active and controlled by CE# and OE#.

If the BYTE# pin is set at logic '0', the device is in byte configuration, and only data I/O pins DQ0–DQ7 are active and controlled by CE# and OE#. The data I/O pins DQ8–DQ14 are

tri-stated, and the DQ15 pin is used as an input for the LSB (A-1) address function.

Requirements for Reading Array Data

To read array data from the outputs, the system must drive the CE# and OE# pins to V_{IL}. CE# is the power control and selects the device. OE# is the output control and gates array data to the output pins. WE# should remain at V_{IH}. The BYTE# pin determines whether the device outputs array data in words or bytes.

The internal state machine is set for reading array data upon device power-up, or after a hardware reset. This ensures that no spurious alteration of the memory content occurs during the power transition. No command is necessary in this mode to obtain array data. Standard microprocessor read cycles that assert valid addresses on the device address inputs produce valid data on the device data outputs. The device remains enabled for read access until the command register contents are altered.

See [“Requirements for Reading Array Data” on page 11](#) for more information. Refer to the AC Read-Only Operations table for timing specifications and to [Figure 14, on page 38](#) for the timing diagram. I_{CC1} in the DC Characteristics table represents the active current specification for reading array data.

Writing Commands/Command Sequences

To write a command or command sequence (which includes programming data to the device and erasing sectors of memory), the system must drive WE# and CE# to V_{IL} , and OE# to V_{IH} .

For program operations, the BYTE# pin determines whether the device accepts program data in bytes or words. Refer to [“Word/Byte Configuration” on page 11](#) for more information.

The device features an **Unlock Bypass** mode to facilitate faster programming. Once the device enters the Unlock Bypass mode, only two write cycles are required to program a word or byte, instead of four. The [“Word/Byte Configuration” on page 11](#) section contains details on programming data to the device using both standard and Unlock Bypass command sequences.

An erase operation can erase one sector, multiple sectors, or the entire device. [Table 2, on page 13](#) through [Table 5, on page 16](#) indicate the address space that each sector occupies. A “sector address” is the address bits required to uniquely select a sector.

I_{CC2} in the DC Characteristics table represents the active current specification for the write mode. The [“AC Characteristics” on page 38](#) section contains timing specification tables and timing diagrams for write operations.

Accelerated Program Operation

The device offers accelerated program operations through the ACC function. This is one of two functions provided by the WP#/ACC pin.

This function is primarily intended to allow faster manufacturing throughput at the factory.

If the system asserts V_{HH} on this pin, the device automatically enters the aforementioned Unlock Bypass mode, temporarily unprotects any protected sectors, and uses the higher voltage on the pin to reduce the time required for program operations. The system would use a two-cycle program command sequence as required by the Unlock Bypass mode. Removing V_{HH} from the WP#/ACC pin returns the device to normal operation. Note that the WP#/ACC pin must not be at V_{HH} for operations other than accelerated programming, or device damage may result. In addition, the WP#/ACC pin must not be left floating or unconnected; inconsistent behavior of the device may result.

Autoselect Functions

If the system writes the autoselect command sequence, the device enters the autoselect mode. The system can then read autoselect codes from the internal register (which is separate from the memory array) on DQ7–DQ0. Standard read cycle timings apply in this mode. Refer to the [“Autoselect Mode” on page 16](#) and [“Autoselect Command Sequence” on page 25](#) sections for more information.

I_{CC6} and I_{CC7} in the DC Characteristics table represent the current specifications for read-while-program and read-while-erase, respectively.

Standby Mode

When the system is not reading or writing to the device, it can place the device in the standby mode. In this mode, current consumption is greatly reduced, and the outputs are placed in the high impedance state, independent of the OE# input.

The device enters the CMOS standby mode when the CE# and RESET# pins are both held at $V_{CC} \pm 0.3$ V. (Note that this is a more restricted voltage range than V_{IH} .) If CE# and RESET# are held at V_{IH} , but not within $V_{CC} \pm 0.3$ V, the device is in the standby mode, but the standby current is greater. The device requires standard access time (t_{CE}) for read access when the device is in either of these standby modes, before it is ready to read data.

If the device is deselected during erasure or programming, the device draws active current until the operation is completed.

I_{CC3} in the DC Characteristics table represents the standby current specification.

Automatic Sleep Mode

The automatic sleep mode minimizes Flash device energy consumption. The device automatically enables this mode when addresses remain stable for $t_{ACC} + 30$ ns. The automatic sleep mode is independent of the CE#, WE#, and OE# control signals. Standard address access timings provide new data when addresses are changed. While in sleep mode, output data is latched and always available to the system. I_{CC4} in the "DC Characteristics" on page 35 table represents the automatic sleep mode current specification.

RESET#: Hardware Reset Pin

The RESET# pin provides a hardware method of resetting the device to reading array data. When the RESET# pin is driven low for at least a period of t_{RP} , the device immediately terminates any operation in progress, tristates all output pins, and ignores all read/write commands for the duration of the RESET# pulse. The device also resets the internal state machine to reading array data. The operation that was interrupted should be reinitiated once the device is ready to accept another command sequence, to ensure data integrity.

Current is reduced for the duration of the RESET# pulse. When RESET# is held at $V_{SS} \pm 0.3$ V, the device draws CMOS standby current

(I_{CC4}). If RESET# is held at V_{IL} but not within $V_{SS} \pm 0.3$ V, the standby current is greater.

The RESET# pin may be tied to the system reset circuitry. A system reset would thus also reset the Flash memory, enabling the system to read the boot-up firmware from the Flash memory.

If RESET# is asserted during a program or erase operation, the RY/BY# pin remains a "0" (busy) until the internal reset operation is complete, which requires a time of t_{READY} (during Embedded Algorithms). The system can thus monitor RY/BY# to determine whether the reset operation is complete. If RESET# is asserted when a program or erase operation is not executing (RY/BY# pin is "1"), the reset operation is completed within a time of t_{READY} (not during Embedded Algorithms). The system can read data t_{RH} after the RESET# pin returns to V_{IH} .

Refer to the AC Characteristics tables for RESET# parameters and to Figure 15, on page 39 for the timing diagram.

Output Disable Mode

When the OE# input is at V_{IH} , output from the device is disabled. The output pins are placed in the high impedance state.

Table 2. Top Boot Sector Addresses (Am29LV320DT) (Sheet 1 of 2)

Sector	Sector Address A20–A12	Sector Size (Kbytes/Kwords)	(x8) Address Range	(x16) Address Range
SA0	000000xxx	64/32	000000h–00FFFFh	000000h–07FFFFh
SA1	000001xxx	64/32	010000h–01FFFFh	008000h–0FFFFh
SA2	000010xxx	64/32	020000h–02FFFFh	010000h–17FFFFh
SA3	000011xxx	64/32	030000h–03FFFFh	018000h–01FFFFh
SA4	000100xxx	64/32	040000h–04FFFFh	020000h–027FFFh
SA5	000101xxx	64/32	050000h–05FFFFh	028000h–02FFFFh
SA6	000110xxx	64/32	060000h–06FFFFh	030000h–037FFFh
SA7	000111xxx	64/32	070000h–07FFFFh	038000h–03FFFFh
SA8	001000xxx	64/32	080000h–08FFFFh	040000h–047FFFh
SA9	001001xxx	64/32	090000h–09FFFFh	048000h–04FFFFh
SA10	001010xxx	64/32	0A0000h–0AFFFFh	050000h–057FFFh
SA11	001011xxx	64/32	0B0000h–0BFFFFh	058000h–05FFFFh
SA12	001100xxx	64/32	0C0000h–0CFFFFh	060000h–067FFFh
SA13	001101xxx	64/32	0D0000h–0DFFFFh	068000h–06FFFFh
SA14	001110xxx	64/32	0E0000h–0EFFFFh	070000h–077FFFh
SA15	001111xxx	64/32	0F0000h–0FFFFh	078000h–07FFFFh
SA16	010000xxx	64/32	100000h–10FFFFh	080000h–087FFFh
SA17	010001xxx	64/32	110000h–11FFFFh	088000h–08FFFFh
SA18	010010xxx	64/32	120000h–12FFFFh	090000h–097FFFh

Table 2. Top Boot Sector Addresses (Am29LV320DT) (Sheet 2 of 2)

Sector	Sector Address A20–A12	Sector Size (Kbytes/Kwords)	(x8) Address Range	(x16) Address Range
SA19	010011xxx	64/32	130000h–13FFFFh	098000h–09FFFFh
SA20	010100xxx	64/32	140000h–14FFFFh	0A0000h–0A7FFFh
SA21	010101xxx	64/32	150000h–15FFFFh	0A8000h–0AFFFFh
SA22	010110xxx	64/32	160000h–16FFFFh	0B0000h–0B7FFFh
SA23	010111xxx	64/32	170000h–17FFFFh	0B8000h–0BFFFFh
SA24	011000xxx	64/32	180000h–18FFFFh	0C0000h–0C7FFFh
SA25	011001xxx	64/32	190000h–19FFFFh	0C8000h–0CFFFFh
SA26	011010xxx	64/32	1A0000h–1AFFFFh	0D0000h–0D7FFFh
SA27	011011xxx	64/32	1B0000h–1BFFFFh	0D8000h–0DFFFFh
SA28	011100xxx	64/32	1C0000h–1CFFFFh	0E0000h–0E7FFFh
SA29	011101xxx	64/32	1D0000h–1DFFFFh	0E8000h–0EFFFFh
SA30	011110xxx	64/32	1E0000h–1EFFFFh	0F0000h–0F7FFFh
SA31	011111xxx	64/32	1F0000h–1FFFFFh	0F8000h–0FFFFFh
SA32	100000xxx	64/32	200000h–20FFFFh	100000h–107FFFh
SA33	100001xxx	64/32	210000h–21FFFFh	108000h–10FFFFh
SA34	100010xxx	64/32	220000h–22FFFFh	110000h–117FFFh
SA35	100011xxx	64/32	230000h–23FFFFh	118000h–11FFFFh
SA36	100100xxx	64/32	240000h–24FFFFh	120000h–127FFFh
SA37	100101xxx	64/32	250000h–25FFFFh	128000h–12FFFFh
SA38	100110xxx	64/32	260000h–26FFFFh	130000h–137FFFh
SA39	100111xxx	64/32	270000h–27FFFFh	138000h–13FFFFh
SA40	101000xxx	64/32	280000h–28FFFFh	140000h–147FFFh
SA41	101001xxx	64/32	290000h–29FFFFh	148000h–14FFFFh
SA42	101010xxx	64/32	2A0000h–2AFFFFh	150000h–157FFFh
SA43	101011xxx	64/32	2B0000h–2BFFFFh	158000h–15FFFFh
SA44	101100xxx	64/32	2C0000h–2CFFFFh	160000h–167FFFh
SA45	101101xxx	64/32	2D0000h–2DFFFFh	168000h–16FFFFh
SA46	101110xxx	64/32	2E0000h–2EFFFFh	170000h–177FFFh
SA47	101111xxx	64/32	2F0000h–2FFFFFh	178000h–17FFFFh
SA48	110000xxx	64/32	300000h–30FFFFh	180000h–187FFFh
SA49	110001xxx	64/32	310000h–31FFFFh	188000h–18FFFFh
SA50	110010xxx	64/32	320000h–32FFFFh	190000h–197FFFh
SA51	110011xxx	64/32	330000h–33FFFFh	198000h–19FFFFh
SA52	110100xxx	64/32	340000h–34FFFFh	1A0000h–1A7FFFh
SA53	110101xxx	64/32	350000h–35FFFFh	1A8000h–1AFFFFh
SA54	110110xxx	64/32	360000h–36FFFFh	1B0000h–1B7FFFh
SA55	110111xxx	64/32	370000h–37FFFFh	1B8000h–1BFFFFh
SA56	111000xxx	64/32	380000h–38FFFFh	1C0000h–1C7FFFh
SA57	111001xxx	64/32	390000h–39FFFFh	1C8000h–1CFFFFh
SA58	111010xxx	64/32	3A0000h–3AFFFFh	1D0000h–1D7FFFh
SA59	111011xxx	64/32	3B0000h–3BFFFFh	1D8000h–1DFFFFh
SA60	111100xxx	64/32	3C0000h–3CFFFFh	1E0000h–1E7FFFh
SA61	111101xxx	64/32	3D0000h–3DFFFFh	1E8000h–1EFFFFh
SA62	111110xxx	64/32	3E0000h–3EFFFFh	1F0000h–1F7FFFh
SA63	111111000	8/4	3F0000h–3F1FFFh	1F8000h–1F8FFFh
SA64	111111001	8/4	3F2000h–3F3FFFh	1F9000h–1F9FFFh
SA65	111111010	8/4	3F4000h–3F5FFFh	1FA000h–1FAFFFh
SA66	111111011	8/4	3F6000h–3F7FFFh	1FB000h–1FBFFFh
SA67	111111100	8/4	3F8000h–3F9FFFh	1FC000h–1FCFFFh
SA68	111111101	8/4	3FA000h–3FBFFFh	1FD000h–1FDFFFh
SA69	111111110	8/4	3FC000h–3FDFFFh	1FE000h–1FEFFFh
SA70	111111111	8/4	3FE000h–3FFFFFh	1FF000h–1FFFFFh

Note: The address range is A20:A-1 in byte mode ($BYTE\# = V_{IL}$) or A20:A0 in word mode ($BYTE\# = V_{IH}$).

Table 3. Top Boot SecSi™ Sector Addresses

Sector Address A20–A12	Sector Size (Kbytes/Kwords)	(x8) Address Range	(x16) Address Range
111111xxx	64/32	3F0000h–3FFFFFh	1F8000h–1FFFFFh

Table 4. Bottom Boot Sector Addresses (Am29LV320DB) (Sheet 1 of 2)

Sector	Sector Address A20–A12	Sector Size (Kbytes/Kwords)	(x8) Address Range	(x16) Address Range
SA0	00000000	8/4	00000h–001FFFh	00000h–000FFFh
SA1	00000001	8/4	00200h–003FFFh	00100h–001FFFh
SA2	00000010	8/4	00400h–005FFFh	00200h–002FFFh
SA3	00000011	8/4	00600h–007FFFh	00300h–003FFFh
SA4	00000100	8/4	00800h–009FFFh	00400h–004FFFh
SA5	00000101	8/4	00A00h–00BFFFh	00500h–005FFFh
SA6	00000110	8/4	00C00h–00DFFFh	00600h–006FFFh
SA7	00000111	8/4	00E00h–00FFFFh	00700h–007FFFh
SA8	00001xxx	64/32	01000h–01FFFFh	00800h–00FFFFh
SA9	000010xxx	64/32	02000h–02FFFFh	01000h–017FFFh
SA10	000011xxx	64/32	03000h–03FFFFh	01800h–01FFFFh
SA11	000100xxx	64/32	04000h–04FFFFh	02000h–027FFFh
SA12	000101xxx	64/32	05000h–05FFFFh	02800h–02FFFFh
SA13	000110xxx	64/32	06000h–06FFFFh	03000h–037FFFh
SA14	000111xxx	64/32	07000h–07FFFFh	03800h–03FFFFh
SA15	001000xxx	64/32	08000h–08FFFFh	04000h–047FFFh
SA16	001001xxx	64/32	09000h–09FFFFh	04800h–04FFFFh
SA17	001010xxx	64/32	0A000h–0AFFFFh	05000h–057FFFh
SA18	001011xxx	64/32	0B000h–0BFFFFh	05800h–05FFFFh
SA19	001100xxx	64/32	0C000h–0CFFFFh	06000h–067FFFh
SA20	001101xxx	64/32	0D000h–0DFFFFh	06800h–06FFFFh
SA21	001110xxx	64/32	0E000h–0EFFFFh	07000h–077FFFh
SA22	001111xxx	64/32	0F000h–0FFFFh	07800h–07FFFFh
SA23	010000xxx	64/32	10000h–10FFFFh	08000h–087FFFh
SA24	010001xxx	64/32	11000h–11FFFFh	08800h–08FFFFh
SA25	010010xxx	64/32	12000h–12FFFFh	09000h–097FFFh
SA26	010011xxx	64/32	13000h–13FFFFh	09800h–09FFFFh
SA27	010100xxx	64/32	14000h–14FFFFh	0A000h–0A7FFFh
SA28	010101xxx	64/32	15000h–15FFFFh	0A800h–0AFFFFh
SA29	010110xxx	64/32	16000h–16FFFFh	0B000h–0B7FFFh
SA30	010111xxx	64/32	17000h–17FFFFh	0B800h–0BFFFFh
SA31	011000xxx	64/32	18000h–18FFFFh	0C000h–0C7FFFh
SA32	011001xxx	64/32	19000h–19FFFFh	0C800h–0CFFFFh
SA33	011010xxx	64/32	1A000h–1AFFFFh	0D000h–0D7FFFh
SA34	011011xxx	64/32	1B000h–1BFFFFh	0D800h–0DFFFFh
SA35	011100xxx	64/32	1C000h–1CFFFFh	0E000h–0E7FFFh
SA36	011101xxx	64/32	1D000h–1DFFFFh	0E800h–0EFFFFh
SA37	011110xxx	64/32	1E000h–1EFFFFh	0F000h–0F7FFFh
SA38	011111xxx	64/32	1F000h–1FFFFh	0F800h–0FFFFh
SA39	100000xxx	64/32	20000h–20FFFFh	10000h–107FFFh
SA40	100001xxx	64/32	21000h–21FFFFh	10800h–10FFFFh
SA41	100010xxx	64/32	22000h–22FFFFh	11000h–117FFFh
SA42	100011xxx	64/32	23000h–23FFFFh	11800h–11FFFFh
SA43	100100xxx	64/32	24000h–24FFFFh	12000h–127FFFh
SA44	100101xxx	64/32	25000h–25FFFFh	12800h–12FFFFh
SA45	100110xxx	64/32	26000h–26FFFFh	13000h–137FFFh
SA46	100111xxx	64/32	27000h–27FFFFh	13800h–13FFFFh
SA47	101000xxx	64/32	28000h–28FFFFh	14000h–147FFFh
SA48	101001xxx	64/32	29000h–29FFFFh	14800h–14FFFFh
SA49	101010xxx	64/32	2A000h–2AFFFFh	15000h–157FFFh
SA50	101011xxx	64/32	2B000h–2BFFFFh	15800h–15FFFFh
SA51	101100xxx	64/32	2C000h–2CFFFFh	16000h–167FFFh
SA52	101101xxx	64/32	2D000h–2DFFFFh	16800h–16FFFFh

Table 4. Bottom Boot Sector Addresses (Am29LV320DB) (Sheet 2 of 2)

Sector	Sector Address A20–A12	Sector Size (Kbytes/Kwords)	(x8) Address Range	(x16) Address Range
SA53	101110xxx	64/32	2E0000h–2EFFFFh	170000h–177FFFh
SA54	101111xxx	64/32	2F0000h–2FFFFFh	178000h–17FFFFh
SA55	111000xxx	64/32	300000h–30FFFFh	180000h–187FFFh
SA56	110001xxx	64/32	310000h–31FFFFh	188000h–18FFFFh
SA57	110010xxx	64/32	320000h–32FFFFh	190000h–197FFFh
SA58	110011xxx	64/32	330000h–33FFFFh	198000h–19FFFFh
SA59	110100xxx	64/32	340000h–34FFFFh	1A0000h–1A7FFFh
SA60	110101xxx	64/32	350000h–35FFFFh	1A8000h–1AFFFFh
SA61	110110xxx	64/32	360000h–36FFFFh	1B0000h–1B7FFFh
SA62	110111xxx	64/32	370000h–37FFFFh	1B8000h–1BFFFFh
SA63	111000xxx	64/32	380000h–38FFFFh	1C0000h–1C7FFFh
SA64	111001xxx	64/32	390000h–39FFFFh	1C8000h–1CFFFFh
SA65	111010xxx	64/32	3A0000h–3AFFFFh	1D0000h–1D7FFFh
SA66	111011xxx	64/32	3B0000h–3BFFFFh	1D8000h–1DFFFFh
SA67	111100xxx	64/32	3C0000h–3CFFFFh	1E0000h–1E7FFFh
SA68	111101xxx	64/32	3D0000h–3DFFFFh	1E8000h–1EFFFFh
SA69	111110xxx	64/32	3E0000h–3EFFFFh	1F0000h–1F7FFFh
SA70	111111xxx	64/32	3F0000h–3FFFFFFh	1F8000h–1FFFFFFh

Note: The address range is A20:A-1 in byte mode (BYTE# = V_{IL}) or A20:A0 in word mode (BYTE# = V_{IH}).

Table 5. Bottom Boot SecSi™ Sector Addresses

Sector Address A20–A12	Sector Size (Kbytes/Kwords)	(x8) Address Range	(x16) Address Range
000000xxx	64/32	000000h–00FFFFh	000000h–07FFFh

Autoselect Mode

The autoselect mode provides manufacturer and device identification, and sector protection verification, through identifier codes output on DQ7–DQ0. This mode is primarily intended for programming equipment to automatically match a device to be programmed with its corresponding programming algorithm. However, the autoselect codes can also be accessed in-system through the command register.

When using programming equipment, the autoselect mode requires V_{ID} (11.5 V to 12.5 V) on address pin A9. Address pins A6, A1, and A0 must be as shown in Table 6, on page 16. In addition, when verifying sector protection, the

sector address must appear on the appropriate highest order address bits (see Table 2, on page 13 through Table 5, on page 16). Table 6, on page 16 shows the remaining address bits that are don't care. When all necessary bits are set as required, the programming equipment may then read the corresponding identifier code on DQ7–DQ0.

To access the autoselect codes in-system, the host system can issue the autoselect command via the command register, as shown in Table 14, on page 29. This method does not require V_{ID}. Refer to the "Autoselect Command Sequence" on page 25 section for more information.

Table 6. Autoselect Codes (High Voltage Method)

Description	CE#	OE#	WE#	A20 to A12	A11 to A10	A9	A8 to A7	A6	A5 to A2	A1	A0	DQ8 to DQ15		DQ7 to DQ0
												BYTE# = V _{IH}	BYTE# = V _{IL}	
Manufacturer ID: AMD	L	L	H	X	X	V _{ID}	X	L	X	L	L	X	X	01h
Device ID: Am29LV320D	L	L	H	X	X	V _{ID}	X	L	X	L	H	22h	X	F6 (T), F9h (B)
Sector Protection Verification	L	L	H	SA	X	V _{ID}	X	L	X	H	L	X	X	01h (protected), 00h (unprotected)
SecSi™ Sector Indicator Bit (DQ7)	L	L	H	X	X	V _{ID}	X	L	X	H	H	X	X	99h (factory locked), 19h (not factory locked)

Legend: T = Top Boot Block, B = Bottom Boot Block, L = Logic Low = V_{IL}, H = Logic High = V_{IH}, SA = Sector Address, X = Don't care.

Sector/Sector Block Protection and Unprotection

The hardware sector protection feature disables both program and erase operations in any sector. The hardware sector unprotection feature re-enables both program and erase operations in previously protected sectors. Sector protection/unprotection can be implemented via two methods.

(Note: For the following discussion, the term “sector” applies to both sectors and sector blocks. A sector block consists of two or more adjacent sectors that are protected or unprotected at the same time (see [Table 7, on page 17](#) and [Table 8, on page 17](#)).

Table 7. Top Boot Sector/Sector Block Addresses for Protection/Unprotection

Sector / Sector Block	A20–A12	Sector/Sector Block Size
SA0-SA3	000000XXX, 000001XXX, 000010XXX 000011XXX	256 (4x64) Kbytes
SA4-SA7	0001XXXXX	256 (4x64) Kbytes
SA8-SA11	0010XXXXX	256 (4x64) Kbytes
SA12-SA15	0011XXXXX	256 (4x64) Kbytes
SA16-SA19	0100XXXXX	256 (4x64) Kbytes
SA20-SA23	0101XXXXX	256 (4x64) Kbytes
SA24-SA27	0110XXXXX	256 (4x64) Kbytes
SA28-SA31	0111XXXXX	256 (4x64) Kbytes
SA32-SA35	1000XXXXX	256 (4x64) Kbytes
SA36-SA39	1001XXXXX	256 (4x64) Kbytes
SA40-SA43	1010XXXXX	256 (4x64) Kbytes
SA44-SA47	1011XXXXX	256 (4x64) Kbytes
SA48-SA51	1100XXXXX	256 (4x64) Kbytes
SA52-SA55	1101XXXXX	256 (4x64) Kbytes
SA56-SA59	1110XXXXX	256 (4x64) Kbytes
SA60-SA62	111100XXX, 111101XXX, 111110XXX	192 (3x64) Kbytes
SA63	111111000	8 Kbytes
SA64	111111001	8 Kbytes
SA65	111111010	8 Kbytes
SA66	111111011	8 Kbytes
SA67	111111100	8 Kbytes
SA68	111111101	8 Kbytes
SA69	111111110	8 Kbytes
SA70	111111111	8 Kbytes

Table 8. Bottom Boot Sector/Sector Block Addresses for Protection/Unprotection

Sector / Sector Block	A20–A12	Sector/Sector Block Size
SA70-SA67	111111XXX, 111110XXX, 111101XXX, 111100XXX	256 (4x64) Kbytes
SA66-SA63	1110XXXXX	256 (4x64) Kbytes
SA62-SA59	1101XXXXX	256 (4x64) Kbytes
SA58-SA55	1100XXXXX	256 (4x64) Kbytes
SA54-SA51	1011XXXXX	256 (4x64) Kbytes
SA50-SA47	1010XXXXX	256 (4x64) Kbytes
SA46-SA43	1001XXXXX	256 (4x64) Kbytes
SA42-SA39	1000XXXXX	256 (4x64) Kbytes
SA38-SA35	0111XXXXX	256 (4x64) Kbytes
SA34-SA31	0110XXXXX	256 (4x64) Kbytes
SA30-SA27	0101XXXXX	256 (4x64) Kbytes
SA26-SA23	0100XXXXX	256 (4x64) Kbytes
SA22-SA19	0011XXXXX	256 (4x64) Kbytes
SA18-SA15	0010XXXXX	256 (4x64) Kbytes
SA14-SA11	0001XXXXX	256 (4x64) Kbytes
SA10-SA8	000011XXX, 000010XXX, 000001XXX	192 (3x64) Kbytes
SA7	000000111	8 Kbytes
SA6	000000110	8 Kbytes
SA5	000000101	8 Kbytes
SA4	000000100	8 Kbytes
SA3	000000011	8 Kbytes
SA2	000000010	8 Kbytes
SA1	000000001	8 Kbytes
SA0	000000000	8 Kbytes

Sector Protection and unprotection requires V_{ID} on the RESET# pin only, and can be implemented either in-system or via programming equipment. [Figure 2, on page 19](#) shows the algorithms and [Figure 25, on page 47](#) shows the timing diagram. This method uses standard microprocessor bus cycle timing. For sector unprotect, all unprotected sectors must first be protected prior to the first sector unprotect write cycle.

The sector unprotect algorithm unprotects all sectors in parallel. All previously protected sectors must be individually re-protected. To change data in protected sectors efficiently, the temporary sector unprotect function is available. See “[Temporary Sector Unprotect](#)” on [page 18](#).

The alternate method intended only for programming equipment, and requires V_{ID} on address pin A9 and OE#. This method is

compatible with programmer routines written for earlier 3.0 volt-only AMD flash devices. For detailed information, contact an AMD representative.

The device is shipped with all sectors unprotected. AMD offers the option of programming and protecting sectors at its factory prior to shipping the device through AMD's Express-Flash™ Service. Contact an AMD representative for details.

It is possible to determine whether a sector is protected or unprotected. See "Autoselect Mode" on page 16 for details.

Write Protect (WP#)

The Write Protect function provides a hardware method of protecting certain boot sectors without using V_{ID} . This function is one of two provided by the WP#/ACC pin.

If the system asserts V_{IL} on the WP#/ACC pin, the device disables program and erase functions in the two "outermost" 8 Kbyte boot sectors independently of whether those sectors were protected or unprotected using the method described in "Sector/Sector Block Protection and Unprotection" on page 17. The two outermost 8 Kbyte boot sectors are the two sectors containing the lowest addresses in a bottom-boot-configured device, or the two sectors containing the highest addresses in a top-boot-configured device.

If the system asserts V_{IH} on the WP#/ACC pin, the device reverts to whether the two outermost 8K Byte boot sectors were last set to be protected or unprotected. That is, sector protection or unprotection for these two sectors depends on whether they were last protected or unprotected using the method described in "Sector/Sector Block Protection and Unprotection" on page 17.

Note that the WP#/ACC pin must not be left floating or unconnected; inconsistent behavior of the device may result.

Temporary Sector Unprotect

This feature allows temporary unprotection of previously protected sectors to change data in-system. The Sector Unprotect mode is activated by setting the RESET# pin to V_{ID} (11.5 V – 12.5 V). During this mode, formerly protected sectors can be programmed or erased by selecting the sector addresses. Once V_{ID} is removed from the RESET# pin, all the previously protected sectors are protected again. Figure 1, on page 18 shows the algorithm, and Figure

23, on page 46 shows the timing diagrams, for this feature.

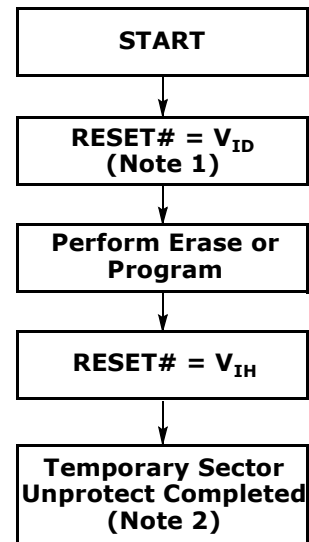

Notes:

1. All protected sectors unprotected (If WP#/ACC = V_{IL} , outermost boot sectors remain protected).
2. All previously protected sectors are protected once again.

Figure 1. Temporary Sector Unprotect Operation

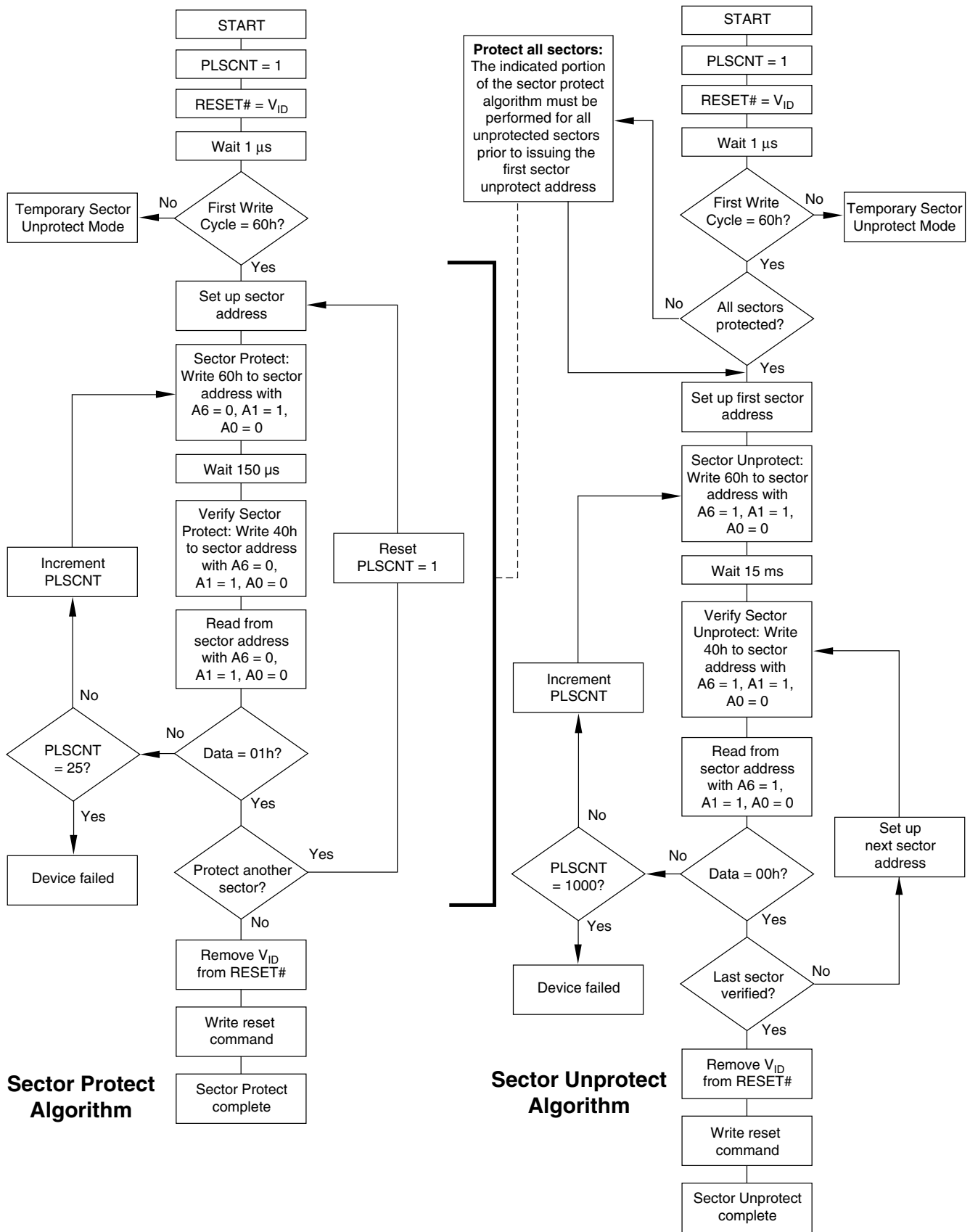

Figure 2. In-System Sector Protect/Unprotect Algorithms

SecSi™ Sector (Secured Silicon) Flash Memory Region

The Secured Silicon Sector (SecSi Sector) feature provides a Flash memory region that enables permanent part identification through an Electronic Serial Number (ESN). The SecSi Sector uses a SecSi Sector Indicator Bit (DQ7) to indicate whether or not the SecSi Sector is locked when shipped from the factory. This bit is permanently set at the factory and cannot be changed, which prevents cloning of a factory locked part. This ensures the security of the ESN once the product is shipped to the field.

Note that the Am29LV320D has a SecSi Sector size of 64 Kbytes. AMD devices designated as replacements or substitutes, such as the Am29LV320M, have 256 bytes. This should be considered during system design.

AMD offers the device with the SecSi Sector either factory locked or customer lockable. The factory-locked version is always protected when shipped from the factory, and has the SecSi Sector Indicator Bit permanently set to a "1." The customer-lockable version is shipped with the SecSi Sector unprotected, allowing customers to utilize the that sector in any manner they choose. The customer-lockable version has the SecSi Sector Indicator Bit permanently set to a "0." Thus, the SecSi Sector Indicator Bit prevents customer-lockable devices from being used to replace devices that are factory locked.

The system accesses the SecSi Sector through a command sequence (see "Enter SecSi™ Sector/Exit SecSi Sector Command Sequence" on page 26). After the system writes the Enter SecSi Sector command sequence, it may read the SecSi Sector by using the addresses normally occupied by the boot sectors. This mode of operation continues until the system issues the Exit SecSi Sector command sequence, or until power is removed from the device. On power-up, or following a hardware reset, the device reverts to sending commands to the boot sectors.

Factory Locked: SecSi Sector Programmed and Protected at the Factory

In a factory locked device, the SecSi Sector is protected when the device is shipped from the factory. The SecSi Sector cannot be modified in any way. The device is available preprogrammed with one of the following:

- A random, secure ESN only

- Customer code through the ExpressFlash service
- Both a random, secure ESN and customer code through the ExpressFlash service.

In devices that have an ESN, a Bottom Boot device has the 16-byte (8-word) ESN in sector 0 at addresses 00000h–0000Fh in byte mode (or 00000h–00007h in word mode). In the Top Boot device the ESN is in sector 63 at addresses 3F0000h–3F000Fh in byte mode (or 1F8000h–1F8007h in word mode). Note that in upcoming top boot versions of this device, the ESN is located in sector 70 at addresses 3FE000h–3FE00Fh in byte mode (or 1FF000h–1FF007h in word mode).

Customers may opt to have their code programmed by AMD through the AMD ExpressFlash service. AMD programs the customer's code, with or without the random ESN. The devices are then shipped from AMD's factory with the SecSi Sector permanently locked. Contact an AMD representative for details on using AMD's ExpressFlash service.

Customer Lockable: SecSi Sector NOT Programmed or Protected at the Factory

The customer lockable version allows the SecSi Sector to be programmed once and then permanently locked after it ships from AMD. **Note that the Am29LV320D has a SecSi Sector size of 64 Kbytes. AMD devices designated as replacements or substitutes, such as the Am29LV320M, have 256 bytes. This should be considered during system design. Additionally, note the change in the location of the ESN in upcoming top boot factory locked devices.** Note that the accelerated programming (ACC) and unlock bypass functions are not available when programming the SecSi Sector.

The SecSi Sector area can be protected using the following procedures:

- Write the three-cycle Enter SecSi Region command sequence, and then follow the in-system sector protect algorithm as shown in [Figure 2, on page 19](#), except that *RESET#* may be at either V_{IH} or V_{ID} . This allows in-system protection of the SecSi Sector without raising any device pin to a high voltage. Note that this method is only applicable to the SecSi Sector.
- To verify the protect/unprotect status of the SecSi Sector, follow the algorithm shown in [Figure 3, on page 21](#).

Once the SecSi Sector is locked and verified, the system must write the Exit SecSi Sector Region command sequence to return to reading and writing the remainder of the array.

The SecSi Sector protection must be used with caution since, once protected, there is no procedure available for unprotecting the SecSi Sector area and none of the bits in the SecSi Sector memory space can be modified in any way.

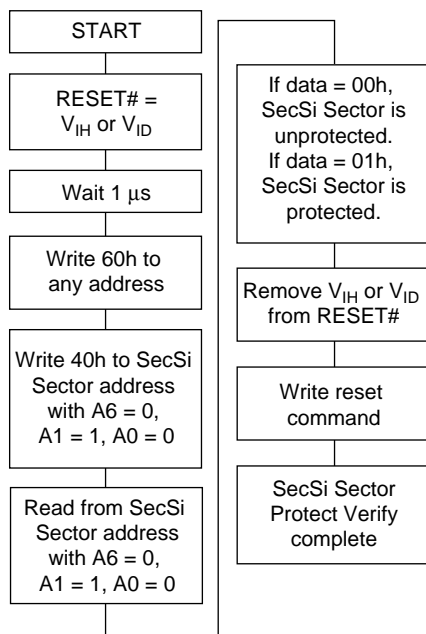

Figure 3. SecSi Sector Protect Verify

Hardware Data Protection

The command sequence requirement of unlock cycles for programming or erasing provides data protection against inadvertent writes (refer to [Table 14, on page 29](#) for command definitions). In addition, the following hardware data protection measures prevent accidental erasure or programming, which might otherwise be caused by spurious system level signals during V_{CC} power-up and power-down transitions, or from system noise.

Low V_{CC} Write Inhibit

When V_{CC} is less than V_{LKO} , the device does not accept any write cycles. This protects data during V_{CC} power-up and power-down. The command register and all internal program/erase circuits are disabled, and the device resets to the read mode. Subsequent writes are ignored

until V_{CC} is greater than V_{LKO} . The system must provide the proper signals to the control pins to prevent unintentional writes when V_{CC} is greater than V_{LKO} .

Write Pulse “Glitch” Protection

Noise pulses of less than 5 ns (typical) on OE#, CE# or WE# do not initiate a write cycle.

Logical Inhibit

Write cycles are inhibited by holding any one of OE# = V_{IL} , CE# = V_{IH} or WE# = V_{IH} . To initiate a write cycle, CE# and WE# must be a logical zero while OE# is a logical one.

Power-Up Write Inhibit

If WE# = CE# = V_{IL} and OE# = V_{IH} during power up, the device does not accept commands on the rising edge of WE#. The internal state machine is automatically reset to the read mode on power-up.

COMMON FLASH MEMORY INTERFACE (CFI)

The Common Flash Interface (CFI) specification outlines device and host system software interrogation handshake, which allows specific vendor-specified software algorithms to be used for entire families of devices. Software support can then be device-independent, JEDEC ID-independent, and forward- and backward-compatible for the specified flash device families. Flash vendors can standardize their existing interfaces for long-term compatibility.

This device enters the CFI Query mode when the system writes the CFI Query command, 98h, to address 55h in word mode (or address AAh in byte mode), any time the device is ready to read array data. The system can read CFI information at the addresses given in [Table 9, on page 22](#) through [Table 12, on page 24](#). To terminate reading CFI data, the system must write the reset command.

The system can also write the CFI query command when the device is in the autoselect mode. The device enters the CFI query mode, and the system can read CFI data at the addresses given in [Table 9, on page 22](#) through [Table 12, on page 24](#). The system must write the reset command to return the device to the reading array data.

For further information, please refer to the CFI Specification and CFI Publication 100, available via the World Wide Web at <http://www.amd.com/flash/cfi>. Alternatively, contact an AMD representative for copies of these documents.

Table 9. CFI Query Identification String

Addresses (Word Mode)	Addresses (Byte Mode)	Data	Description
10h 11h 12h	20h 22h 24h	0051h 0052h 0059h	Query Unique ASCII string "QRY"
13h 14h	26h 28h	0002h 0000h	Primary OEM Command Set
15h 16h	2Ah 2Ch	0040h 0000h	Address for Primary Extended Table
17h 18h	2Eh 30h	0000h 0000h	Alternate OEM Command Set (00h = none exists)
19h 1Ah	32h 34h	0000h 0000h	Address for Alternate OEM Extended Table (00h = none exists)

Table 10. System Interface String

Addresses (Word Mode)	Addresses (Byte Mode)	Data	Description
1Bh	36h	0027h	V _{CC} Min. (write/erase) D7-D4: volt, D3-D0: 100 millivolt
1Ch	38h	0036h	V _{CC} Max. (write/erase) D7-D4: volt, D3-D0: 100 millivolt
1Dh	3Ah	0000h	V _{pp} Min. voltage (00h = no V _{pp} pin present)
1Eh	3Ch	0000h	V _{pp} Max. voltage (00h = no V _{pp} pin present)
1Fh	3Eh	0004h	Typical timeout per single byte/word write 2 ^N μs
20h	40h	0000h	Typical timeout for Min. size buffer write 2 ^N μs (00h = not supported)
21h	42h	000Ah	Typical timeout per individual block erase 2 ^N ms
22h	44h	0000h	Typical timeout for full chip erase 2 ^N ms (00h = not supported)
23h	46h	0005h	Max. timeout for byte/word write 2 ^N times typical
24h	48h	0000h	Max. timeout for buffer write 2 ^N times typical
25h	4Ah	0004h	Max. timeout per individual block erase 2 ^N times typical
26h	4Ch	0000h	Max. timeout for full chip erase 2 ^N times typical (00h = not supported)

Table 11. Device Geometry Definition

Addresses (Word Mode)	Addresses (Byte Mode)	Data	Description
27h	4Eh	0016h	Device Size = 2 ^N byte
28h 29h	50h 52h	0002h 0000h	Flash Device Interface description (refer to CFI publication 100)
2Ah 2Bh	54h 56h	0000h 0000h	Max. number of bytes in multi-byte write = 2 ^N (00h = not supported)
2Ch	58h	0002h	Number of Erase Block Regions within device
2Dh 2Eh 2Fh 30h	5Ah 5Ch 5Eh 60h	0007h 0000h 0020h 0000h	Erase Block Region 1 Information (refer to the CFI specification or CFI publication 100)
31h 32h 33h 34h	62h 64h 66h 68h	003Eh 0000h 0000h 0001h	Erase Block Region 2 Information
35h 36h 37h 38h	6Ah 6Ch 6Eh 70h	0000h 0000h 0000h 0000h	Erase Block Region 3 Information
39h 3Ah 3Bh 3Ch	72h 74h 76h 78h	0000h 0000h 0000h 0000h	Erase Block Region 4 Information

Table 12. Primary Vendor-Specific Extended Query

Addresses (Word Mode)	Addresses (Byte Mode)	Data	Description
40h 41h 42h	80h 82h 84h	0050h 0052h 0049h	Query-unique ASCII string "PRI"
43h	86h	0031h	Major version number, ASCII
44h	88h	0031h	Minor version number, ASCII
45h	8Ah	0000h	Address Sensitive Unlock (Bits 1-0) 0 = Required, 1 = Not Required Silicon Revision Number (Bits 7-2)
46h	8Ch	0002h	Erase Suspend 0 = Not Supported, 1 = To Read Only, 2 = To Read & Write
47h	8Eh	0004h	Sector Protect 0 = Not Supported, X = Number of sectors in per group
48h	90h	0001h	Sector Temporary Unprotect 00 = Not Supported, 01 = Supported
49h	92h	0004h	Sector Protect/Unprotect scheme 04 = 29LV800 mode
4Ah	94h	0000h	Simultaneous Operation 00 = Not Supported
4Bh	96h	0000h	Burst Mode Type 00 = Not Supported, 01 = Supported
4Ch	98h	0000h	Page Mode Type 00 = Not Supported, 01 = 4 Word Page, 02 = 8 Word Page
4Dh	9Ah	00B5h	ACC (Acceleration) Supply Minimum 00h = Not Supported, D7-D4: Volt, D3-D0: 100 mV
4Eh	9Ch	00C5h	ACC (Acceleration) Supply Maximum 00h = Not Supported, D7-D4: Volt, D3-D0: 100 mV
4Fh	9Eh	000Xh	Top/Bottom Boot Sector Flag 02h = Bottom Boot Device, 03h = Top Boot Device

COMMAND DEFINITIONS

Writing specific address and data commands or sequences into the command register initiates device operations. [Table 14, on page 29](#) defines the valid register command sequences. *Note that writing incorrect address and data values or writing them in the improper sequence may place the device in an unknown state. A reset command is required to return the device to normal operation.*

All addresses are latched on the falling edge of WE# or CE#, whichever happens later. All data is latched on the rising edge of WE# or CE#, whichever happens first. Refer to the AC Characteristics section for timing diagrams.

Reading Array Data

The device is automatically set to reading array data after device power-up. No commands are required to retrieve data. The device is ready to read array data after completing an Embedded Program or Embedded Erase algorithm.

After the device accepts an Erase Suspend command, the device enters the erase-suspend-read mode, after which the system can read data from any non-erase-suspended sector. After completing a programming operation in the Erase Suspend mode, the system may once again read array data with the same exception. See [“Erase Suspend/Erase Resume Commands” on page 28](#) for more information.

The system *must* issue the reset command to return the device to the read (or erase-suspend-read) mode if DQ5 goes high during an active program or erase operation, or if the device is in the autoselect mode. See the next section, [“Reset Command](#), for more information.

See also [“Requirements for Reading Array Data” on page 11](#) for more information. The Read-Only Operations table provides the read parameters, and [Figure 14, on page 38](#) shows the timing diagram.

Reset Command

Writing the reset command resets the device to the read or erase-suspend-read mode. Address bits are don't cares for this command.

The reset command may be written between the sequence cycles in an erase command sequence before erasing begins. This resets the device to which the system was writing to the read mode. Once erasure begins, however, the device ignores reset commands until the operation is complete.

The reset command may be written between the sequence cycles in a program command se-

quence before programming begins. This resets the device to which the system was writing to the read mode. If the program command sequence is written to a sector that is in the Erase Suspend mode, writing the reset command returns the device to the erase-suspend-read mode. Once programming begins, however, the device ignores reset commands until the operation is complete.

The reset command may be written between the sequence cycles in an autoselect command sequence. Once in the autoselect mode, the reset command must be written to return to the read mode. If the device entered the autoselect mode while in the Erase Suspend mode, writing the reset command returns the device to the erase-suspend-read mode.

If DQ5 goes high during a program or erase operation, writing the reset command returns the device to the read mode (or erase-suspend-read mode if the device was in Erase Suspend).

Autoselect Command Sequence

The autoselect command sequence allows the host system to read several identifier codes at specific addresses:

Table 13. Autoselect Codes

Identifier Code	Address
Manufacturer ID	00h
Device ID	01h
SecSi Sector Factory Protect	03h
Sector Group Protect Verify	(SA)02h

[Table 14, on page 29](#) shows the address and data requirements. This method is an alternative to that shown in [Table 6, on page 16](#), which is intended for PROM programmers and requires V_{DD} on address pin A9. The autoselect command sequence may be written to an address within sector that is either in the read or erase-suspend-read mode. The autoselect command may not be written while the device is actively programming or erasing.

The autoselect command sequence is initiated by first writing two unlock cycles. This is followed by a third write cycle that contains the autoselect command. The device then enters the autoselect mode. The system may read at any address any number of times without initiating another autoselect command sequence.

The system must write the reset command to return to the read mode (or erase-suspend-read mode if the device was previously in Erase Suspend).

Enter SecSi™ Sector/Exit SecSi Sector Command Sequence

The SecSi Sector region provides a secured data area containing a random, sixteen-byte electronic serial number (ESN). The system can access the SecSi Sector region by issuing the three-cycle Enter SecSi Sector command sequence. The device continues to access the SecSi Sector region until the system issues the four-cycle Exit SecSi Sector command sequence. The Exit SecSi Sector command sequence returns the device to normal operation. [Table 14, on page 29](#) shows the address and data requirements for both command sequences. Note that the ACC function and unlock bypass modes are not available when the device enters the SecSi Sector. See also “[SecSi™ Sector \(Secured Silicon\) Flash Memory Region](#)” on [page 20](#) for further information.

Byte/Word Program Command Sequence

The system may program the device by word or byte, depending on the state of the BYTE# pin. Programming is a four-bus-cycle operation. The program command sequence is initiated by writing two unlock write cycles, followed by the program set-up command. The program address and data are written next, which in turn initiate the Embedded Program algorithm. The system is *not* required to provide further controls or timings. The device automatically provides internally generated program pulses and verifies the programmed cell margin. [Table 14, on page 29](#) shows the address and data requirements for the byte program command sequence. *Note that the autoselect, SecSi Sector, and CFI modes are unavailable while a programming operation is in progress.*

When the Embedded Program algorithm is complete, the device then returns to the read mode and addresses are no longer latched. The system can determine the status of the program operation by using DQ7, DQ6, or RY/BY#. Refer to “[Write Operation Status](#)” on [page 30](#) for information on these status bits.

Any commands written to the device during the Embedded Program Algorithm are ignored. Note that a **hardware reset** immediately terminates the program operation. The program command sequence should be reinitiated once the device returns to the read mode, to ensure data integrity.

Programming is allowed in any sequence and across sector boundaries. **A bit cannot be programmed from “0” back to a “1.”** At-

tempting to do so may cause the device to set DQ5 = 1, or cause the DQ7 and DQ6 status bits to indicate the operation was successful. However, a succeeding read shows that the data is still “0.” Only erase operations can convert a “0” to a “1.”

Unlock Bypass Command Sequence

The unlock bypass feature allows the system to program bytes or words to the device faster than using the standard program command sequence. The unlock bypass command sequence is initiated by first writing two unlock cycles. This is followed by a third write cycle containing the unlock bypass command, 20h. The device then enters the unlock bypass mode. A two-cycle unlock bypass program command sequence is all that is required to program in this mode. The first cycle in this sequence contains the unlock bypass program command, A0h; the second cycle contains the program address and data. Additional data is programmed in the same manner. This mode dispenses with the initial two unlock cycles required in the standard program command sequence, resulting in faster total programming time. [Table 14, on page 29](#) shows the requirements for the command sequence.

During the unlock bypass mode, only the Unlock Bypass Program and Unlock Bypass Reset commands are valid. To exit the unlock bypass mode, the system must issue the two-cycle unlock bypass reset command sequence. The first cycle must contain the data 90h. The second cycle need only contain the data 00h. The device then returns to the read mode.

The device offers accelerated program operations through the WP#/ACC pin. When the system asserts V_{HH} on the WP#/ACC pin, the device automatically enters the Unlock Bypass mode. The system may then write the two-cycle Unlock Bypass program command sequence. The device uses the higher voltage on the WP#/ACC pin to accelerate the operation. Note that the WP#/ACC pin must not be at V_{HH} any operation other than accelerated programming, or device damage may result. In addition, the WP#/ACC pin must not be left floating or unconnected; inconsistent behavior of the device may result.

[Figure 4, on page 27](#) illustrates the algorithm for the program operation. Refer to the table “[Erase and Program Operations](#)” on [page 41](#) for parameters, and [Figure 18, on page 42](#) for timing diagrams.

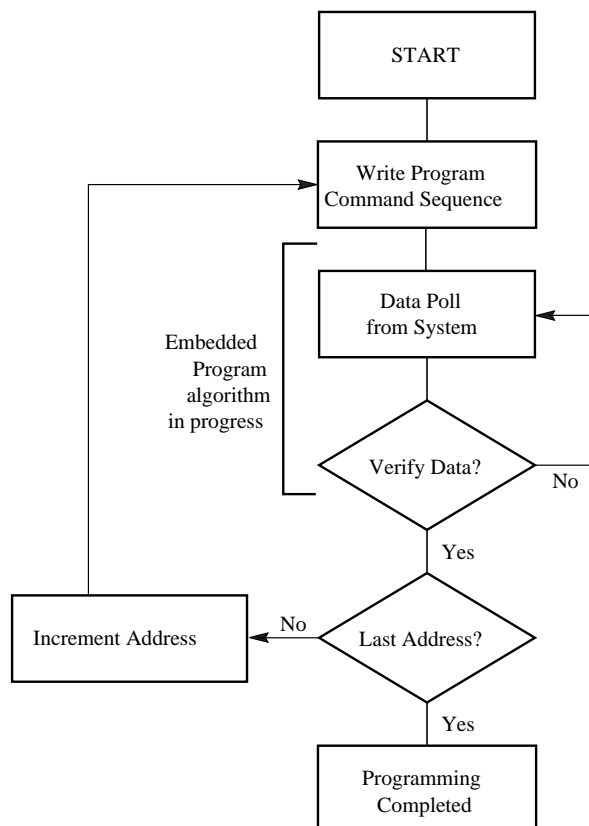

Note: See [Table 14, on page 29](#) for program command sequence.

Figure 4. Program Operation

Chip Erase Command Sequence

Chip erase is a six bus cycle operation. The chip erase command sequence is initiated by writing two unlock cycles, followed by a set-up command. Two additional unlock write cycles are then followed by the chip erase command, which in turn invokes the Embedded Erase algorithm. The device does *not* require the system to preprogram prior to erase. The Embedded Erase algorithm automatically preprograms and verifies the entire memory for an all zero data pattern prior to electrical erase. The system is not required to provide any controls or timings during these operations. [Table 14, on page 29](#) shows the address and data requirements for the chip erase command sequence. *Note that the autoselect, SecSi Sector, and CFI modes are unavailable while an erase operation is in progress.*

When the Embedded Erase algorithm is complete, the device returns to the read mode and addresses are no longer latched. The system can determine the status of the erase operation by using DQ7, DQ6, DQ2, or RY/BY#. Refer to ["Write Operation Status" on page 30](#) for information on these status bits.

Any commands written during the chip erase operation are ignored. However, note that a **hardware reset** immediately terminates the erase operation. If that occurs, the chip erase command sequence should be reinitiated once the device returns to reading array data, to ensure data integrity.

[Figure 5, on page 28](#) illustrates the algorithm for the erase operation. Refer to [table "Erase and Program Operations" on page 41](#) for parameters, and [Figure 19, on page 43](#) section for timing diagrams.

Sector Erase Command Sequence

Sector erase is a six bus cycle operation. The sector erase command sequence is initiated by writing two unlock cycles, followed by a set-up command. Two additional unlock cycles are written, and are then followed by the address of the sector to be erased, and the sector erase command. [Table 14, on page 29](#) shows the address and data requirements for the sector erase command sequence. *Note that the autoselect, SecSi Sector, and CFI modes are unavailable while an erase operation is in progress.*

The device does *not* require the system to preprogram prior to erase. The Embedded Erase algorithm automatically programs and verifies the entire memory for an all zero data pattern prior to electrical erase. The system is not required to provide any controls or timings during these operations.

After the command sequence is written, a sector erase time-out of 50 μ s occurs. During the time-out period, additional sector addresses and sector erase commands may be written. Loading the sector erase buffer may be done in any sequence, and the number of sectors may be from one sector to all sectors. The time between these additional cycles must be less than 50 μ s, otherwise the last address and command may not be accepted, and erasure may begin. It is recommended that processor interrupts be disabled during this time to ensure all commands are accepted. The interrupts can be re-enabled after the last Sector Erase command is written. **Any command other than Sector Erase or Erase Suspend during the**

time-out period resets the device to the read mode. The system must rewrite the command sequence and any additional addresses and commands.

The system can monitor DQ3 to determine if the sector erase timer timed out (See the section "DQ3: Sector Erase Timer" on page 32.). The time-out begins from the rising edge of the final WE# pulse in the command sequence.

When the Embedded Erase algorithm is complete, the device returns to reading array data and addresses are no longer latched. The system can determine the status of the erase operation by reading DQ7, DQ6, DQ2, or RY/BY# in the erasing sector. Refer to "Write Operation Status" on page 30 for information on these status bits.

Once the sector erase operation begins, only the Erase Suspend command is valid. All other commands are ignored. However, note that a **hardware reset** immediately terminates the erase operation. If that occurs, the sector erase command sequence should be reinitiated once the device returns to reading array data, to ensure data integrity.

Figure 5, on page 28 illustrates the algorithm for the erase operation. Refer to table "Erase and Program Operations" on page 41 for parameters, and Figure 19, on page 43 for timing diagrams.

Erase Suspend/Erase Resume Commands

The Erase Suspend command, B0h, allows the system to interrupt a sector erase operation and then read data from, or program data to, any sector not selected for erasure. This command is valid only during the sector erase operation, including the 50 μs time-out period during the sector erase command sequence. The Erase Suspend command is ignored if written during the chip erase operation or Embedded Program algorithm.

When the Erase Suspend command is written during the sector erase operation, the device requires a maximum of 20 μs to suspend the erase operation. However, when the Erase Suspend command is written during the sector erase time-out, the device immediately terminates the time-out period and suspends the erase operation.

After the erase operation is suspended, the device enters the erase-suspend-read mode. The system can read data from or program data to any sector not selected for erasure. (The device "erase suspends" all sectors selected for erasure.) Reading at any address within erase-sus-

pending sectors produces status information on DQ7–DQ0. The system can use DQ7, or DQ6 and DQ2 together, to determine if a sector is actively erasing or is erase-suspended. Refer to the "Write Operation Status" on page 30 section for information on these status bits.

After an erase-suspended program operation is complete, the device returns to the erase-suspend-read mode. The system can determine the status of the program operation using the DQ7 or DQ6 status bits, just as in the standard Byte Program operation. Refer to "Write Operation Status" on page 30 for more information.

In the erase-suspend-read mode, the system can also issue the autoselect command sequence. Refer to "Autoselect Mode" on page 16 and "Autoselect Command Sequence" on page 25 for details.

To resume the sector erase operation, the system must write the Erase Resume command. Further writes of the Resume command are ignored. Another Erase Suspend command can be written after the chip resumes erasing.

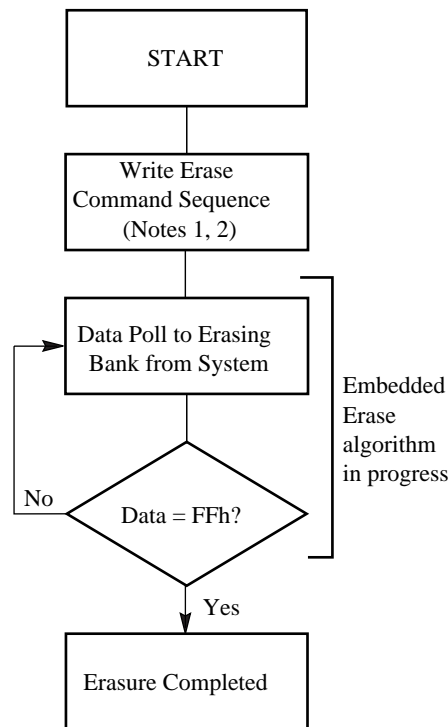

Notes:

1. See Table 14, on page 29 for erase command sequence.
2. See the section on DQ3 for information on the sector erase timer.

Figure 5. Erase Operation

Command Definitions

Table 14. Am29LV320D Command Definitions

Command Sequence (Note 1)			Cycles	Bus Cycles (Notes 2–5)													
				First		Second		Third		Fourth		Fifth		Sixth			
				Addr	Data	Addr	Data	Addr	Data	Addr	Data	Addr	Data	Addr	Data		
Read (Note 6)			1	RA	RD												
Reset (Note 7)			1	XXX	F0												
Autoselect (Note 8)	Manufacturer ID	Word	4	555	AA	2AA	55	555	90	X00	01						
		Byte		AAA		555		AAA									
	Device ID	Word	4	555	AA	2AA	55	555	90	X01	(see Table 6)						
		Byte		AAA		555		AAA		X02							
	SecSi Sector Factory Protect (Note 9)	Word	4	555	AA	2AA	55	555	90	X03	99/19						
		Byte		AAA		555		AAA				X06					
	Sector Protect Verify (Note 10)	Word	4	555	AA	2AA	55	555	90	(SA)X02	00/01						
		Byte		AAA		555		AAA				(SA)X04					
Enter SecSi™ Sector Region	Word	3	555	AA	2AA	55	555	88									
	Byte		AAA		555		AAA										
Exit SecSi Sector Region	Word	4	555	AA	2AA	55	555	90	XXX	00							
	Byte		AAA		555		AAA										
Program	Word	4	555	AA	2AA	55	555	A0	PA	PD							
	Byte		AAA		555		AAA										
Unlock Bypass	Word	3	555	AA	2AA	55	555	20									
	Byte		AAA		555		AAA										
Unlock Bypass Program (Note 11)			2	XXX	A0	PA	PD										
Unlock Bypass Reset (Note 12)			2	XXX	90	XXX	00										
Chip Erase	Word	6	555	AA	2AA	55	555	80	555	AA	2AA	55	555	10			
	Byte		AAA		555		AAA				AAA				555		AAA
Sector Erase	Word	6	555	AA	2AA	55	555	80	555	AA	2AA	55	SA	30			
	Byte		AAA		555		AAA				AAA				555		SA
Erase Suspend (Note 13)			1	XXX	B0												
Erase Resume (Note 14)			1	XXX	30												
CFI Query (Note 15)	Word	1	55	98													
	Byte		AA														

Legend:

X = Don't care

RA = Address of the memory location to be read.

RD = Data read from location RA during read operation.

PA = Address of the memory location to be programmed.

Addresses latch on the falling edge of the WE# or CE# pulse, whichever happens later.

PD = Data to be programmed at location PA. Data latches on the rising edge of WE# or CE# pulse, whichever happens first.

SA = Address of the sector to be verified (in autoselect mode) or erased. Address bits A20–A12 uniquely select any sector.

Notes:

- See Table 1 for description of bus operations.
- All values are in hexadecimal.
- Except for the read cycle and the fourth cycle of the autoselect command sequence, all bus cycles are write cycles.
- Data bits DQ15–DQ8 are don't care in command sequences, except for RD and PD.
- Unless otherwise noted, address bits A20–A11 are don't cares.
- No unlock or command cycles required when device is in read mode.
- The Reset command is required to return to the read mode (or to the erase-suspend-read mode if previously in Erase Suspend) when a device is in the autoselect mode, or if DQ5 goes high (while the device is providing status information).
- The fourth cycle of the autoselect command sequence is a read cycle. Data bits DQ15–DQ8 are don't care. See the Autoselect Command Sequence section for more information.
- The data is 99h for factory locked and 19h for not factory locked.

- The data is 00h for an unprotected sector and 01h for a protected sector.
- The Unlock Bypass command is required prior to the Unlock Bypass Program command.
- The Unlock Bypass Reset command is required to return to the read mode when the device is in the unlock bypass mode.
- The system may read and program in non-erasing sectors, or enter the autoselect mode, when in the Erase Suspend mode. The Erase Suspend command is valid only during a sector erase operation.
- The Erase Resume command is valid only during the Erase Suspend mode.
- Command is valid when device is ready to read array data or when device is in autoselect mode.

WRITE OPERATION STATUS

The device provides several bits to determine the status of a program or erase operation: DQ2, DQ3, DQ5, DQ6, and DQ7. Table 15, on page 33 and the following subsections describe the function of these bits. DQ7 and DQ6 each offer a method for determining whether a program or erase operation is complete or in progress. The device also provides a hardware-based output signal, RY/BY#, to determine whether an Embedded Program or Erase operation is in progress or is completed.

DQ7: Data# Polling

The Data# Polling bit, DQ7, indicates to the host system whether an Embedded Program or Erase algorithm is in progress or completed, or whether a device is in Erase Suspend. Data# Polling is valid after the rising edge of the final WE# pulse in the command sequence.

During the Embedded Program algorithm, the device outputs on DQ7 the complement of the datum programmed to DQ7. This DQ7 status also applies to programming during Erase Suspend. When the Embedded Program algorithm is complete, the device outputs the datum programmed to DQ7. The system must provide the program address to read valid status information on DQ7. If a program address falls within a protected sector, Data# Polling on DQ7 is active for approximately 1 μ s, then the device returns to the read mode.

During the Embedded Erase algorithm, Data# Polling produces a "0" on DQ7. When the Embedded Erase algorithm is complete, or if the device enters the Erase Suspend mode, Data# Polling produces a "1" on DQ7. The system must provide an address within any of the sectors selected for erasure to read valid status information on DQ7.

After an erase command sequence is written, if all sectors selected for erasing are protected, Data# Polling on DQ7 is active for approximately 100 μ s, then the device returns to the read mode. If not all selected sectors are protected, the Embedded Erase algorithm erases the unprotected sectors, and ignores the selected sectors that are protected. However, if the system reads DQ7 at an address within a protected sector, the status may not be valid.

Just prior to the completion of an Embedded Program or Erase operation, DQ7 may change asynchronously with DQ0–DQ6 while Output Enable (OE#) is asserted low. That is, the device may change from providing status information to valid data on DQ7. Depending on

when the system samples the DQ7 output, it may read the status or valid data. Even if the device completes the program or erase operation and DQ7 contains valid data, the data outputs on DQ0–DQ6 may be still invalid. Valid data on DQ0–DQ7 appears on successive read cycles.

Table 15, on page 33 shows the outputs for Data# Polling on DQ7. Figure 6, on page 30 shows the Data# Polling algorithm. Figure 20, on page 44 in the AC Characteristics section shows the Data# Polling timing diagram.

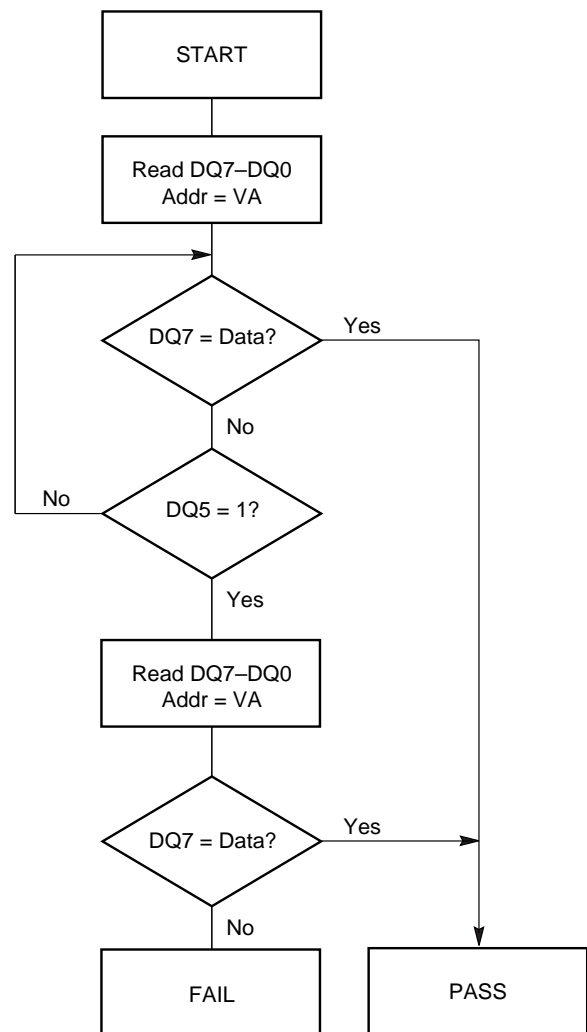

Notes:

1. VA = Valid address for programming. During a sector erase operation, a valid address is any sector address within the sector being erased. During chip erase, a valid address is any non-protected sector address.
2. DQ7 should be rechecked even if DQ5 = "1" because DQ7 may change simultaneously with DQ5.

Figure 6. Data# Polling Algorithm

R_Y/B_Y#: Ready/Busy#

The R_Y/B_Y# is a dedicated, open-drain output pin which indicates whether an Embedded Algorithm is in progress or complete. The R_Y/B_Y# status is valid after the rising edge of the final WE# pulse in the command sequence. Since R_Y/B_Y# is an open-drain output, several R_Y/B_Y# pins can be tied together in parallel with a pull-up resistor to V_{CC}.

If the output is low (Busy), the device is actively erasing or programming. (This includes programming in the Erase Suspend mode.) If the output is high (Ready), the device is in the read mode, the standby mode, or in the erase-suspend-read mode. Table 15, on page 33 shows the outputs for R_Y/B_Y#.

DQ6: Toggle Bit I

Toggle Bit I on DQ6 indicates whether an Embedded Program or Erase algorithm is in progress or complete, or whether the device entered the Erase Suspend mode. Toggle Bit I may be read at any address, and is valid after the rising edge of the final WE# pulse in the command sequence (prior to the program or erase operation), and during the sector erase time-out.

During an Embedded Program or Erase algorithm operation, successive read cycles to any address cause DQ6 to toggle. The system may use either OE# or CE# to control the read cycles. When the operation is complete, DQ6 stops toggling.

After an erase command sequence is written, if all sectors selected for erasing are protected, DQ6 toggles for approximately 100 μs, then returns to reading array data. If not all selected sectors are protected, the Embedded Erase algorithm erases the unprotected sectors, and ignores the selected sectors that are protected.

The system can use DQ6 and DQ2 together to determine whether a sector is actively erasing or is erase-suspended. When the device is actively erasing (that is, the Embedded Erase algorithm is in progress), DQ6 toggles. When the device enters the Erase Suspend mode, DQ6 stops toggling. However, the system must also use DQ2 to determine which sectors are erasing or erase-suspended. Alternatively, the system can use DQ7 (see the subsection on "DQ7: Data# Polling" on page 30).

If a program address falls within a protected sector, DQ6 toggles for approximately 1 μs after the program command sequence is written, then returns to reading array data.

DQ6 also toggles during the erase-suspend-program mode, and stops toggling once the Embedded Program algorithm is complete.

Table 15, on page 33 shows the outputs for Toggle Bit I on DQ6. Figure 7, on page 31 shows the toggle bit algorithm. Figure 21, on page 45 in the "AC Characteristics" section shows the toggle bit timing diagrams. Figure 22, on page 45 shows the differences between DQ2 and DQ6 in graphical form. See also the subsection on DQ2: Toggle Bit II.

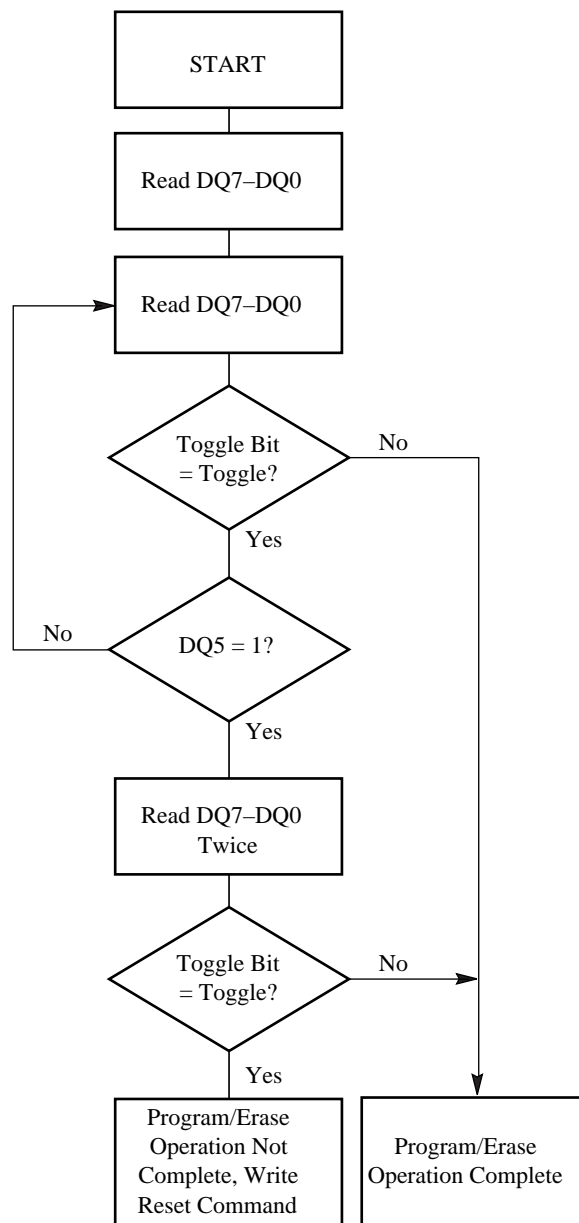

Note: The system should recheck the toggle bit even if DQ5 = "1" because the toggle bit may stop toggling as DQ5 changes to "1." See the subsections on DQ6 and DQ2 for more information.

Figure 7. Toggle Bit Algorithm

DQ2: Toggle Bit II

The "Toggle Bit II" on DQ2, when used with DQ6, indicates whether a particular sector is actively erasing (that is, the Embedded Erase algorithm is in progress), or whether that sector is erase-suspended. Toggle Bit II is valid after the rising edge of the final WE# pulse in the command sequence.

DQ2 toggles when the system reads at addresses within those sectors that were selected for erasure. (The system may use either OE# or CE# to control the read cycles.) But DQ2 cannot distinguish whether the sector is actively erasing or is erase-suspended. DQ6, by comparison, indicates whether the device is actively erasing, or is in Erase Suspend, but cannot distinguish which sectors are selected for erasure. Thus, both status bits are required for sector and mode information. Refer to [Table 15, on page 33](#) to compare outputs for DQ2 and DQ6.

[Figure 7, on page 31](#) shows the toggle bit algorithm in flowchart form, and the section "[DQ2: Toggle Bit II](#)" on [page 32](#) explains the algorithm. See also the DQ6: Toggle Bit I subsection. [Figure 21, on page 45](#) shows the toggle bit timing diagram. [Figure 22, on page 45](#) shows the differences between DQ2 and DQ6 in graphical form.

Reading Toggle Bits DQ6/DQ2

Refer to [Figure 7, on page 31](#) for the following discussion. Whenever the system initially begins reading toggle bit status, it must read DQ7–DQ0 at least twice in a row to determine whether a toggle bit is toggling. Typically, the system would note and store the value of the toggle bit after the first read. After the second read, the system would compare the new value of the toggle bit with the first. If the toggle bit is not toggling, the device completed the program or erase operation. The system can read array data on DQ7–DQ0 on the following read cycle.

However, if after the initial two read cycles, the system determines that the toggle bit is still toggling, the system also should note whether the value of DQ5 is high (see the section on DQ5). If it is, the system should then determine again whether the toggle bit is toggling, since the toggle bit may have stopped toggling just as DQ5 went high. If the toggle bit is no longer toggling, the device successfully completed the program or erase operation. If it is still toggling, the device did not complete the operation successfully, and the system must

write the reset command to return to reading array data.

The remaining scenario is that the system initially determines that the toggle bit is toggling and DQ5 has not gone high. The system may continue to monitor the toggle bit and DQ5 through successive read cycles, determining the status as described in the previous paragraph. Alternatively, it may choose to perform other system tasks. In this case, the system must start at the beginning of the algorithm when it returns to determine the status of the operation (top of [Figure 7, on page 31](#)).

DQ5: Exceeded Timing Limits

DQ5 indicates whether the program or erase time exceeded a specified internal pulse count limit. Under these conditions DQ5 produces a "1," indicating that the program or erase cycle was not successfully completed.

The device may output a "1" on DQ5 if the system tries to program a "1" to a location that was previously programmed to "0." **Only an erase operation can change a "0" back to a "1."** Under this condition, the device halts the operation, and when the timing limit is exceeded, DQ5 produces a "1."

Under both these conditions, the system must write the reset command to return to the read mode (or to the erase-suspend-read mode if the device was previously in the erase-suspend-program mode).

DQ3: Sector Erase Timer

After writing a sector erase command sequence, the system may read DQ3 to determine whether or not erasure started. (The sector erase timer does not apply to the chip erase command.) If additional sectors are selected for erasure, the entire time-out also applies after each additional sector erase command. When the time-out period is complete, DQ3 switches from a "0" to a "1." If the time between additional sector erase commands from the system can be assumed to be less than 50 μ s, the system need not monitor DQ3. See also the Sector Erase Command Sequence section.

After the sector erase command is written, the system should read the status of DQ7 (Data# Polling) or DQ6 (Toggle Bit I) to ensure that the device accepted the command sequence, and then read DQ3. If DQ3 is "1," the Embedded Erase algorithm started; all further commands (except Erase Suspend) are ignored until the erase operation is complete. If DQ3 is "0," the

device accepts additional sector erase commands. To ensure the command is accepted, the system software should check the status of DQ3 prior to and following each subsequent sector erase command. If DQ3 is high on the

second status check, the last command might not have been accepted.

Table 15, on page 33 shows the status of DQ3 relative to the other status bits.

Table 15. Write Operation Status

Status		DQ7 (Note 2)	DQ6	DQ5 (Note 1)	DQ3	DQ2 (Note 2)	RY/BY#	
Standard Mode	Embedded Program Algorithm	DQ7#	Toggle	0	N/A	No toggle	0	
	Embedded Erase Algorithm	0	Toggle	0	1	Toggle	0	
Erase Suspend Mode	Erase-Suspend-Read	Erase Suspended Sector	1	No toggle	0	N/A	Toggle	1
		Non-Erase Suspended Sector	Data	Data	Data	Data	Data	1
	Erase-Suspend-Program	DQ7#	Toggle	0	N/A	N/A	0	

Notes:

1. DQ5 switches to '1' when an Embedded Program or Embedded Erase operation exceeds the maximum timing limits. Refer to the section on DQ5 for more information.
2. DQ7 and DQ2 require a valid address when reading status information. Refer to the appropriate subsection for further details.

ABSOLUTE MAXIMUM RATINGS

Storage Temperature
 Plastic Packages. -65°C to +150°C
 Ambient Temperature
 with Power Applied. -65°C to +125°C
 Voltage with Respect to Ground

Notes:

1. Minimum DC voltage on input or I/O pins is -0.5 V. During voltage transitions, input or I/O pins may overshoot V_{SS} to -2.0 V for periods of up to 20 ns. Maximum DC voltage on input or I/O pins is $V_{CC} + 0.5$ V. See Figure 8, on page 34. During voltage transitions, input or I/O pins may overshoot to $V_{CC} + 2.0$ V for periods up to 20 ns. See Figure 9, on page 34.
2. Minimum DC input voltage on pins A9, OE#, RESET#, and WP#/ACC is -0.5 V. During voltage transitions, A9, OE#, WP#/ACC, and RESET# may overshoot V_{SS} to -2.0 V for periods of up to 20 ns. See Figure 8, on page 34. Maximum DC input voltage on pin A9 is +12.5 V which may overshoot to +14.0 V for periods up to 20 ns. Maximum DC input voltage on WP#/ACC is +9.5 V which may overshoot to +12.0 V for periods up to 20 ns.
3. No more than one output may be shorted to ground at a time. Duration of the short circuit should not be greater than one second.

Stresses above those listed under "Absolute Maximum Ratings" may cause permanent damage to the device. This is a stress rating only; functional operation of the device at these or any other conditions above those indicated in the operational sections of this data sheet is not implied. Exposure of the device to absolute maximum rating conditions for extended periods may affect device reliability.

V_{CC} (Note 1) -0.5 V to +4.0 V
 A9, OE#, RESET#,
 and WP#/ACC (Note 2). . -0.5 V to +12.5 V
 All other pins (Note 1) -0.5 V to $V_{CC} + 0.5$ V
 Output Short Circuit Current (Note 3). 200 mA

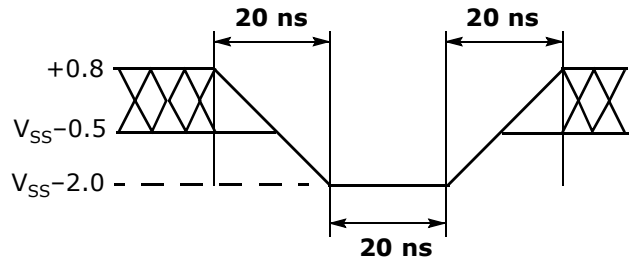

Figure 8. Maximum Negative Overshoot Waveform

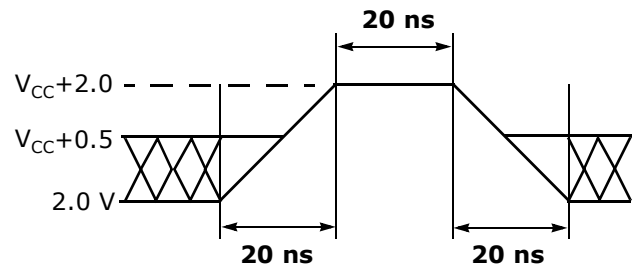

Figure 9. Maximum Positive Overshoot Waveform

OPERATING RANGES

Industrial (I) Devices

Ambient Temperature (T_A). . . . -40°C to +85°C

V_{CC} Supply Voltages

V_{CC} for all devices 2.7 V to 3.6 V

Operating ranges define those limits between which the functionality of the device is guaranteed.

DC CHARACTERISTICS

CMOS Compatible

Parameter Symbol	Parameter Description	Test Conditions	Min	Typ	Max	Unit
I_{LI}	Input Load Current	$V_{IN} = V_{SS}$ to V_{CC} , $V_{CC} = V_{CC\ max}$			± 3.0	μA
I_{LIT}	A9 Input Load Current	$V_{CC} = V_{CC\ max}$; A9 = 12.5 V			35	μA
I_{LR}	RESET# Input Load Current	$V_{CC} = V_{CC\ max}$; RESET# = 12.5 V			35	μA
I_{LO}	Output Leakage Current	$V_{OUT} = V_{SS}$ to V_{CC} , $V_{CC} = V_{CC\ max}$			± 1.0	μA
I_{CC1}	V_{CC} Active Read Current (Notes 1, 2)	CE# = V_{IL} , OE# = V_{IH} , Byte Mode	5 MHz	10	16	mA
			1 MHz	2	4	
		CE# = V_{IL} , OE# = V_{IH} , Word Mode	5 MHz	10	16	
			1 MHz	2	4	
I_{CC2}	V_{CC} Active Write Current (Notes 2, 3)	CE# = V_{IL} , OE# = V_{IH} , WE# = V_{IL}		15	30	mA
I_{CC3}	V_{CC} Standby Current (Note 2)	CE#, RESET# = $V_{CC} \pm 0.3$ V		0.2	5	μA
I_{CC4}	V_{CC} Reset Current (Note 2)	RESET# = $V_{SS} \pm 0.3$ V		0.2	5	μA
I_{CC5}	Automatic Sleep Mode (Notes 2, 4)	$V_{IH} = V_{CC} \pm 0.3$ V; $V_{IL} = V_{SS} \pm 0.3$ V		0.2	5	μA
V_{IL}	Input Low Voltage		-0.5		0.8	V
V_{IH}	Input High Voltage		$0.7 \times V_{CC}$		$V_{CC} + 0.3$	V
V_{HH}	Voltage for WP#/ACC Sector Protect/Unprotect and Program Acceleration	$V_{CC} = 3.0$ V \pm 10%	11.5		12.5	V
V_{ID}	Voltage for Autoselect and Temporary Sector Unprotect	$V_{CC} = 3.0$ V \pm 10%	11.5		12.5	V
V_{OL}	Output Low Voltage	$I_{OL} = 4.0$ mA, $V_{CC} = V_{CC\ min}$			0.45	V
V_{OH1}	Output High Voltage	$I_{OH} = -2.0$ mA, $V_{CC} = V_{CC\ min}$	$0.85 V_{CC}$			V
V_{OH2}		$I_{OH} = -100$ μA , $V_{CC} = V_{CC\ min}$	$V_{CC} - 0.4$			
V_{LKO}	Low V_{CC} Lock-Out Voltage (Note 5)		2.3		2.5	V

Notes:

1. The I_{CC} current listed is typically less than 2 mA/MHz, with OE# at V_{IH} .
2. Maximum I_{CC} specifications are tested with $V_{CC} = V_{CC\ max}$.
3. I_{CC} active while Embedded Erase or Embedded Program is in progress.
4. Automatic sleep mode enables the low power mode when addresses remain stable for $t_{ACC} + 30$ ns. Typical sleep mode current is 200 nA.
5. Not 100% tested.

DC CHARACTERISTICS
Zero-Power Flash

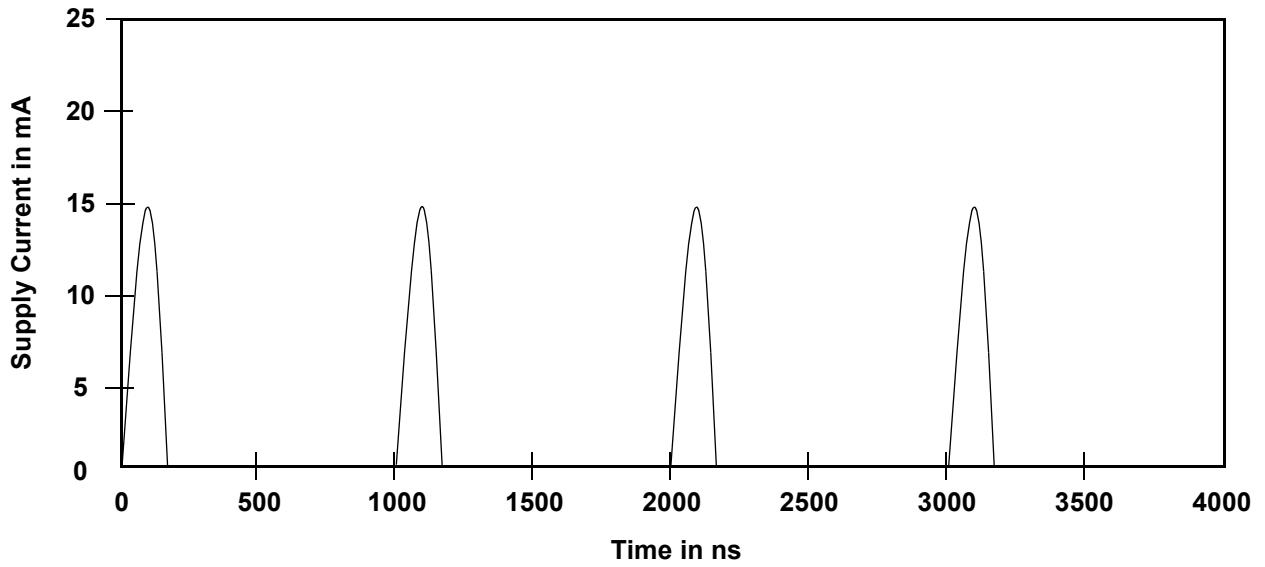

Note: Addresses are switching at 1 MHz

Figure 10. I_{CC1} Current vs. Time (Showing Active and Automatic Sleep Currents)

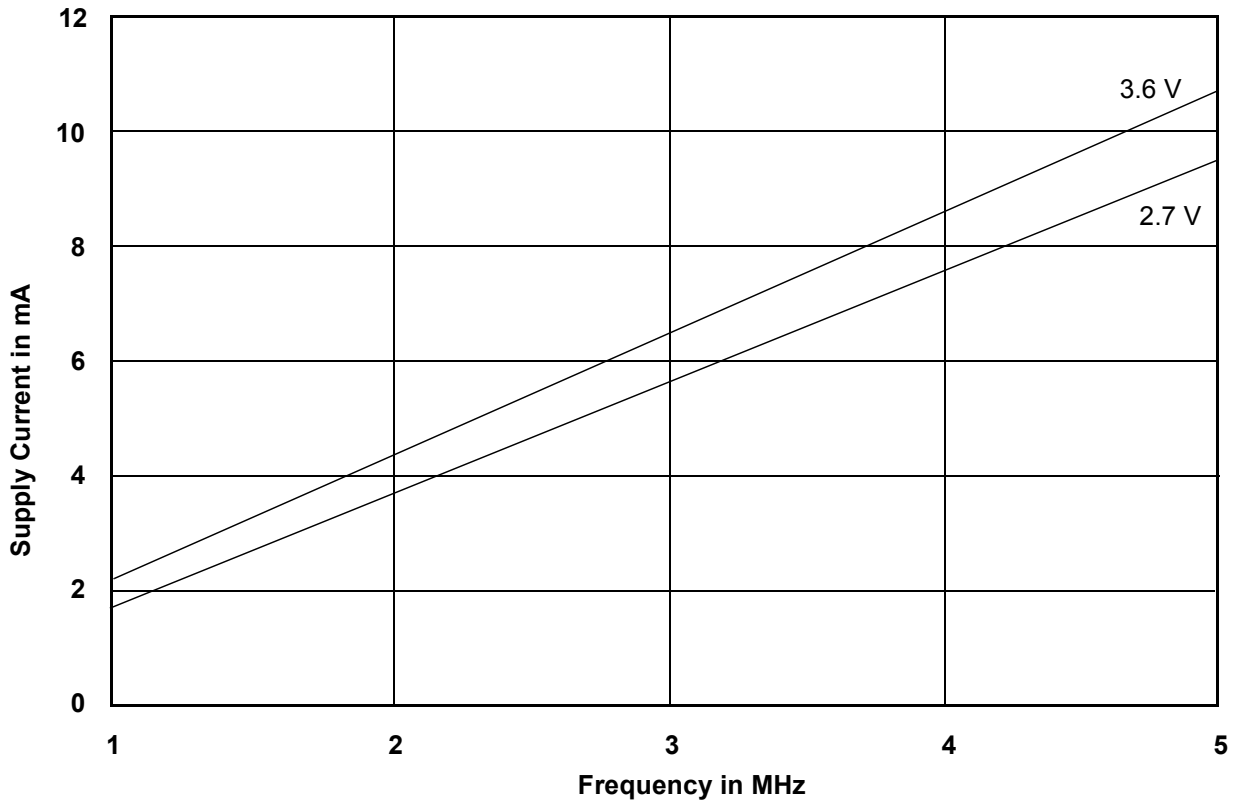

Note: $T = 25\text{ }^{\circ}\text{C}$

Figure 11. Typical I_{CC1} vs. Frequency

TEST CONDITIONS

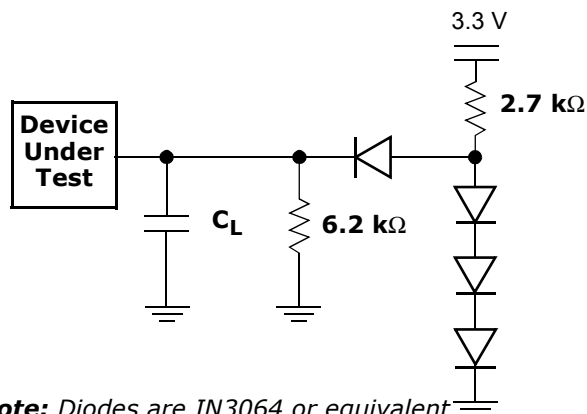

Note: Diodes are IN3064 or equivalent

Figure 12. Test Setup

Table 16. Test Specifications

Test Condition	90	120	Unit
Output Load	1 TTL gate		
Output Load Capacitance, C_L (including jig capacitance)	30	100	pF
Input Rise and Fall Times	5		ns
Input Pulse Levels	0.0–3.0		V
Input timing measurement reference levels	1.5		V
Output timing measurement reference levels	1.5		V

Key To Switching Waveforms

WAVEFORM	INPUTS	OUTPUTS
		Steady
		Changing from H to L
		Changing from L to H
	Don't Care, Any Change Permitted	Changing, State Unknown
	Does Not Apply	Center Line is High Impedance State (High Z)

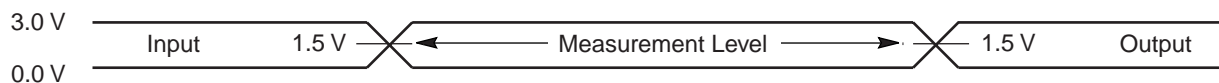

Figure 13. Input Waveforms and Measurement Levels

AC CHARACTERISTICS

Read-Only Operations

Parameter		Description	Test Setup		Speed Options		Unit
JEDEC	Std.				90	120	
t_{AVAV}	t_{RC}	Read Cycle Time (Note 1)		Min	90	120	ns
t_{AVQV}	t_{ACC}	Address to Output Delay	CE#, OE# = V_{IL}	Max	90	120	ns
t_{ELQV}	t_{CE}	Chip Enable to Output Delay	OE# = V_{IL}	Max	90	120	ns
t_{GLQV}	t_{OE}	Output Enable to Output Delay		Max	40	50	ns
t_{EHQZ}	t_{DF}	Chip Enable to Output High Z (Note 1)		Max	16		ns
t_{GHQZ}	t_{DF}	Output Enable to Output High Z (Note 1)		Max	16		ns
t_{AXQX}	t_{OH}	Output Hold Time From Addresses, CE# or OE#, Whichever Occurs First		Min	0		ns
	t_{OEH}	Output Enable Hold Time (Note 1)	Read	Min	0		ns
			Toggle and Data# Polling	Min	10		ns

Notes:

1. Not 100% tested.
2. See [Figure 12, on page 37](#) and [Table 16, on page 37](#) for test specifications.

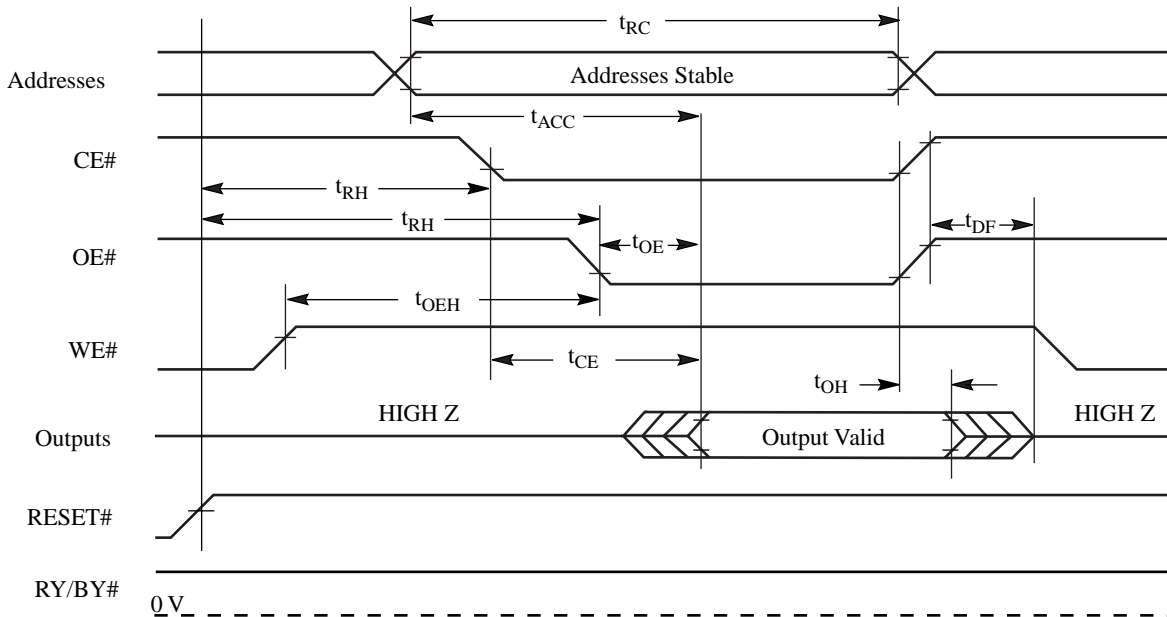

Figure 14. Read Operation Timings

AC CHARACTERISTICS

Hardware Reset (RESET#)

Parameter		Description		All Speed Options	Unit
JEDEC	Std				
	t_{Ready}	RESET# Pin Low (During Embedded Algorithms) to Read Mode (See Note)	Max	20	μs
	t_{Ready}	RESET# Pin Low (NOT During Embedded Algorithms) to Read Mode (See Note)	Max	500	ns
	t_{RP}	RESET# Pulse Width	Min	500	ns
	t_{RH}	Reset High Time Before Read (See Note)	Min	50	ns
	t_{RPD}	RESET# Low to Standby Mode	Min	20	μs
	t_{RB}	RY/BY# Recovery Time	Min	0	ns

Note: Not 100% tested.

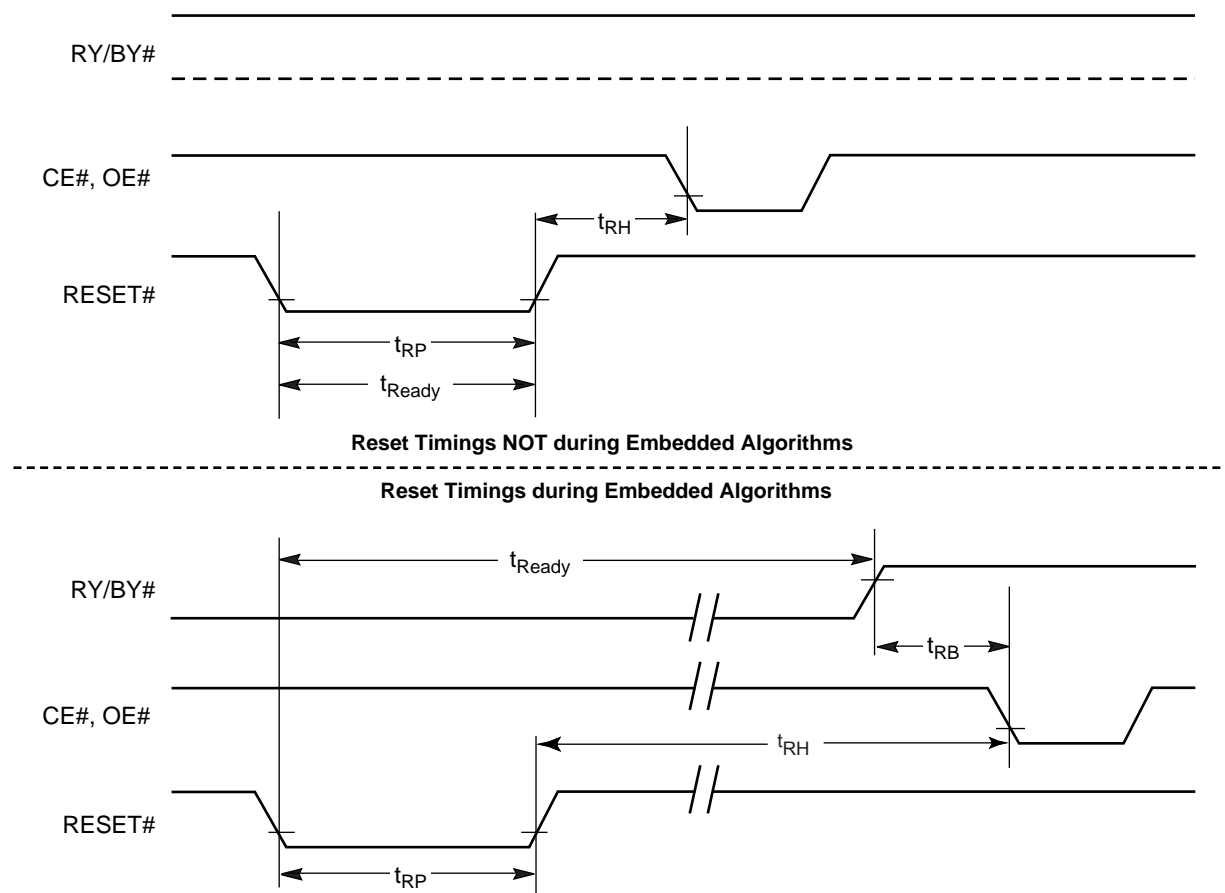

Figure 15. Reset Timings

AC CHARACTERISTICS

Word/Byte Configuration (BYTE#)

Parameter		Description		90	120	Unit
JEDEC	Std.					
	t_{ELFL}/t_{ELFH}	CE# to BYTE# Switching Low or High	Max	5		ns
	t_{FLQZ}	BYTE# Switching Low to Output HIGH Z	Max	16		ns
	t_{FHQV}	BYTE# Switching High to Output Active	Min	90	120	ns

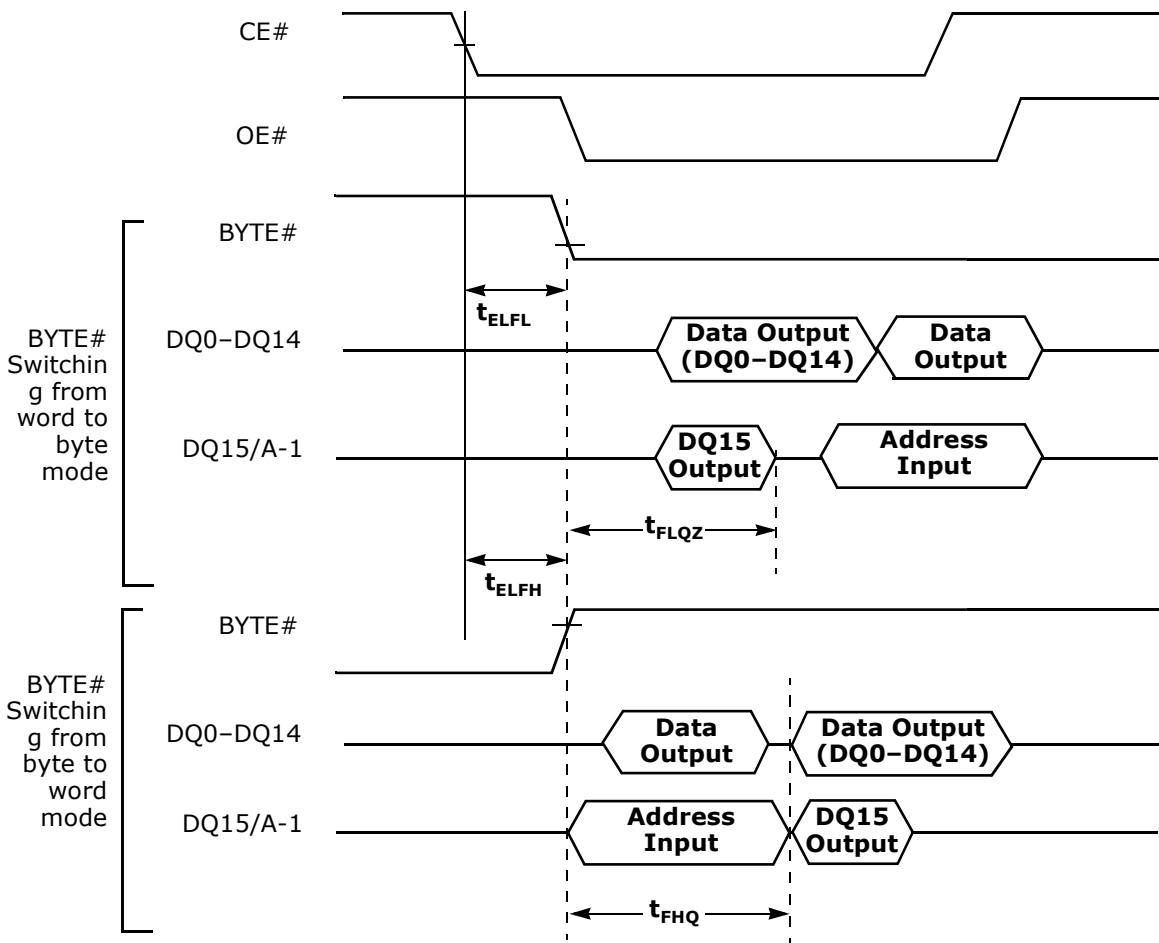
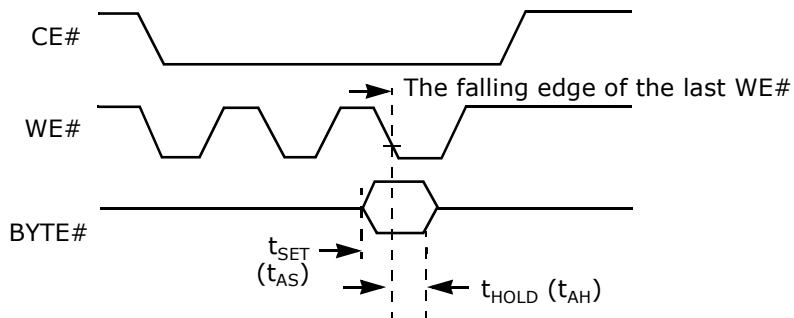

Figure 16. BYTE# Timings for Read Operations



Note: Refer to the Erase/Program Operations table for t_{AS} and t_{AH} specifications.

Figure 17. BYTE# Timings for Write Operations

AC CHARACTERISTICS

Erase and Program Operations

Parameter		Description		90	120	Unit
JEDEC	Std.			Min	Max	
t_{AVAV}	t_{WC}	Write Cycle Time (Note 1)	Min	90	120	ns
t_{AVWL}	t_{AS}	Address Setup Time	Min	0		ns
	t_{ASO}	Address Setup Time to OE# low during toggle bit polling	Min	15		ns
t_{WLAX}	t_{AH}	Address Hold Time	Min	45	50	ns
	t_{AHT}	Address Hold Time From CE# or OE# high during toggle bit polling	Min	0		ns
t_{DVWH}	t_{DS}	Data Setup Time	Min	45	50	ns
t_{WHDX}	t_{DH}	Data Hold Time	Min	0		ns
	t_{OEPH}	Output Enable High during toggle bit polling	Min	20		ns
t_{GHWL}	t_{GHWL}	Read Recovery Time Before Write (OE# High to WE# Low)	Min	0		ns
t_{ELWL}	t_{CS}	CE# Setup Time	Min	0		ns
t_{WHEH}	t_{CH}	CE# Hold Time	Min	0		ns
t_{WLWH}	t_{WP}	Write Pulse Width	Min	35	50	ns
t_{WHDL}	t_{WPH}	Write Pulse Width High	Min	30		ns
	$t_{SR/W}$	Latency Between Read and Write Operations	Min	0		ns
t_{WHWH1}	t_{WHWH1}	Programming Operation (Note 2)	Byte	Typ	9	μ s
			Word	Typ	11	
t_{WHWH1}	t_{WHWH1}	Accelerated Programming Operation, Word or Byte (Note 2)	Typ	7		μ s
t_{WHWH2}	t_{WHWH2}	Sector Erase Operation (Note 2)	Typ	0.7		sec
	t_{VCS}	V _{CC} Setup Time (Note 1)	Min	50		μ s
	t_{RB}	Write Recovery Time from RY/BY#	Min	0		ns
	t_{BUSY}	Program/Erase Valid to RY/BY# Delay	Max	90		ns

Notes:

1. Not 100% tested.
2. See "[Erase And Programming Performance](#)" on page 50 for more information.

AC CHARACTERISTICS

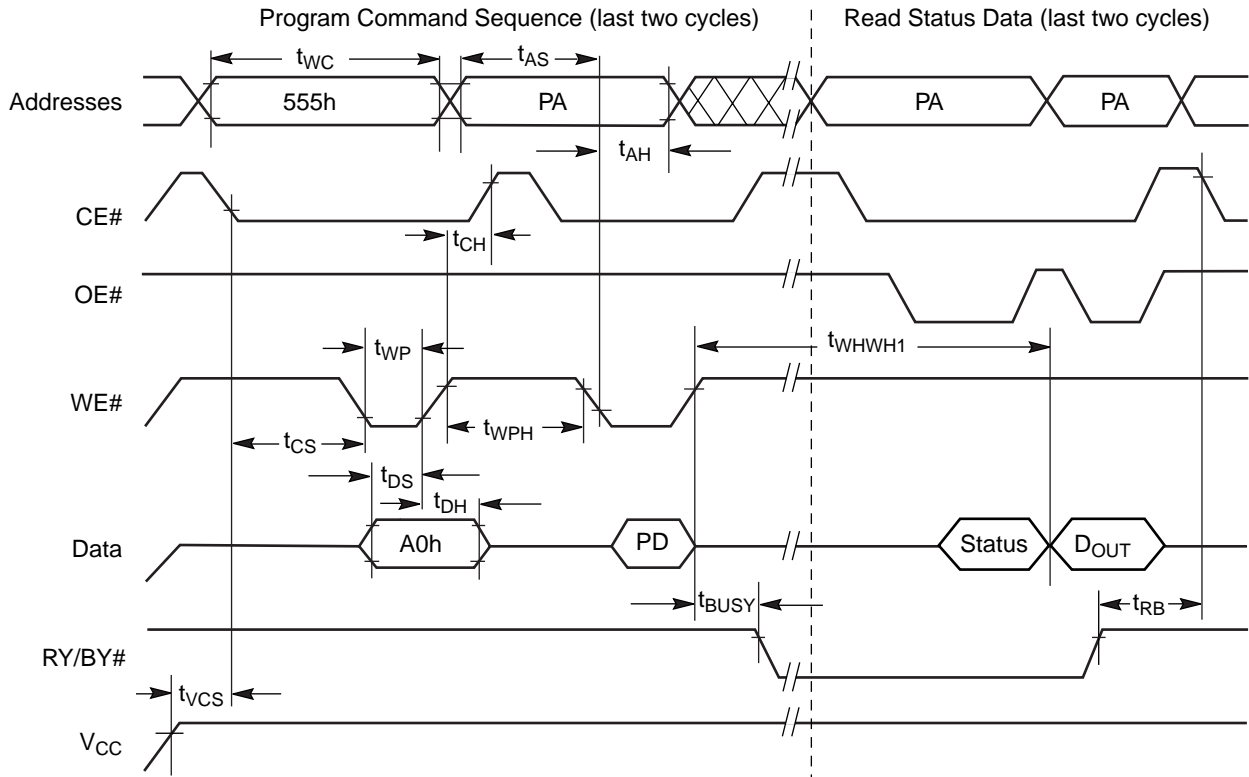

Notes:

1. PA = program address, PD = program data, D_{OUT} is the true data at the program address.
2. Illustration shows device in word mode.

Figure 18. Program Operation Timings

AC CHARACTERISTICS

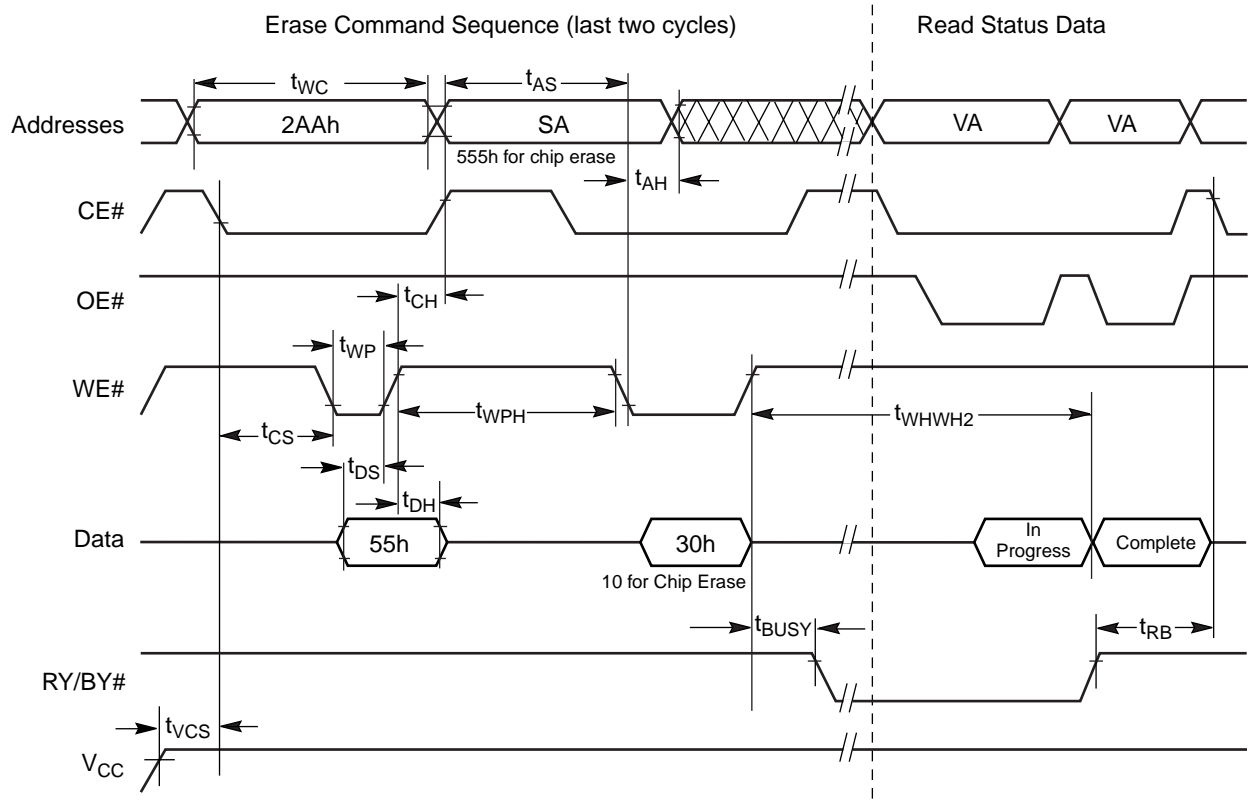

Notes:

1. SA = sector address (for Sector Erase), VA = Valid Address for reading status data (see "Write Operation Status" on page 30).
2. These waveforms are for the word mode.

Figure 19. Chip/Sector Erase Operation Timings

AC CHARACTERISTICS

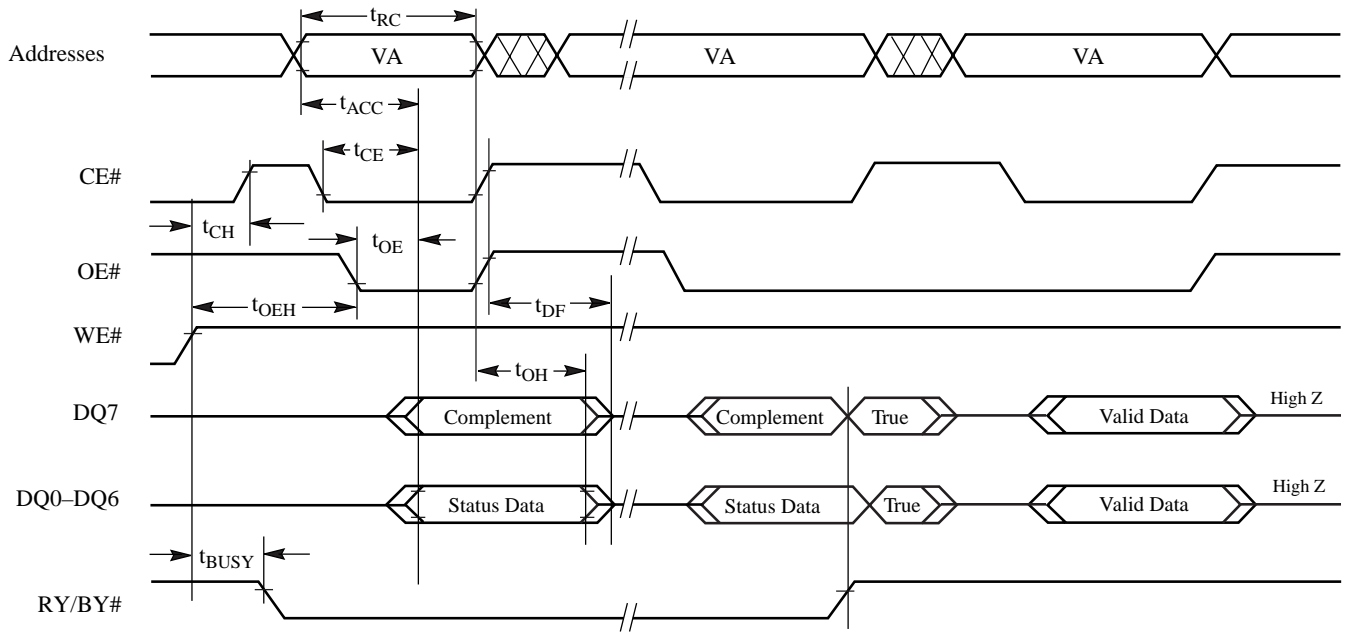

Note: VA = Valid address. Illustration shows first status cycle after command sequence, last status read cycle, and array data read cycle.

Figure 20. Data# Polling Timings (During Embedded Algorithms)

AC CHARACTERISTICS

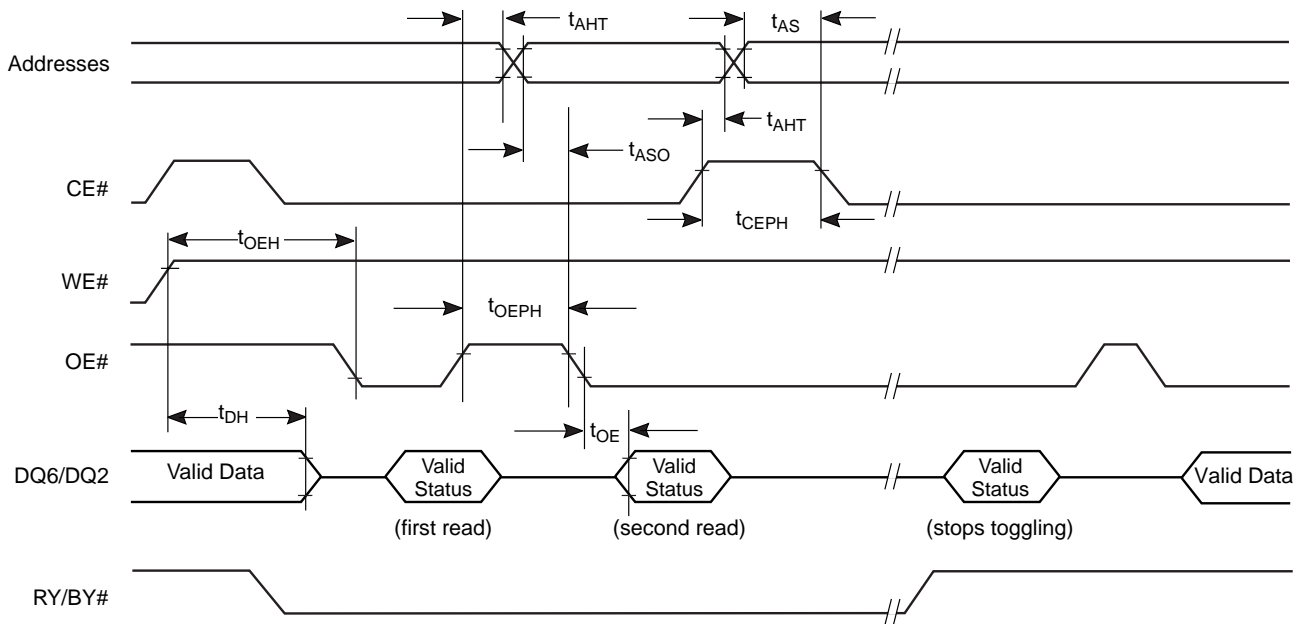

Note: VA = Valid address; not required for DQ6. Illustration shows first two status cycle after command sequence, last status read cycle, and array data read cycle

Figure 21. Toggle Bit Timings (During Embedded Algorithms)

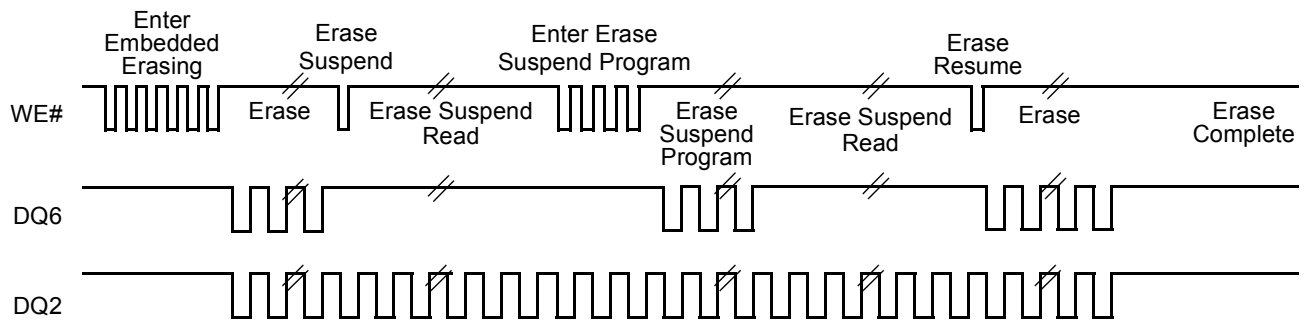

Note: DQ2 toggles only when read at an address within an erase-suspended sector. The system may use OE# or CE# to toggle DQ2 and DQ6.

Figure 22. DQ2 vs. DQ6

AC CHARACTERISTICS

Temporary Sector Unprotect

Parameter		Description		All Speed Options	Unit
JEDEC	Std.				
	t_{VIDR}	V_{ID} Rise and Fall Time (See Note)	Min	500	ns
	t_{VHH}	V_{HH} Rise and Fall Time (See Note)	Min	250	ns
	t_{RSP}	RESET# Setup Time for Temporary Sector Unprotect	Min	4	μ s
	t_{RRB}	RESET# Hold Time from RY/BY# High for Temporary Sector Unprotect	Min	4	μ s

Note: Not 100% tested.

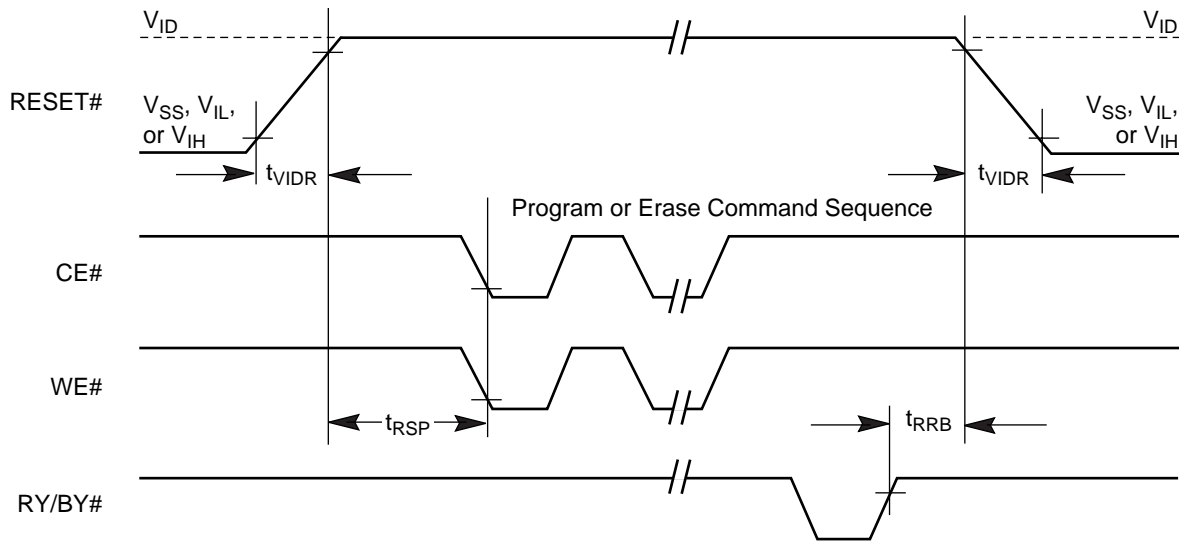

Figure 23. Temporary Sector Unprotect Timing Diagram

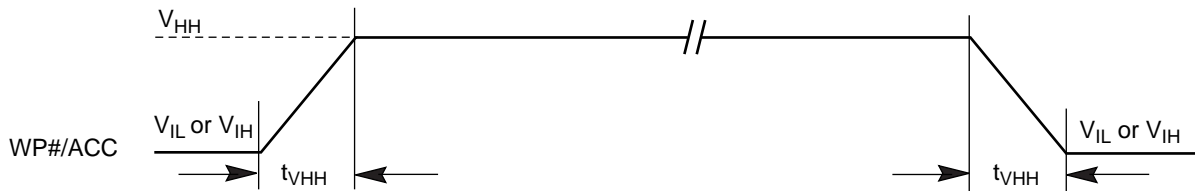
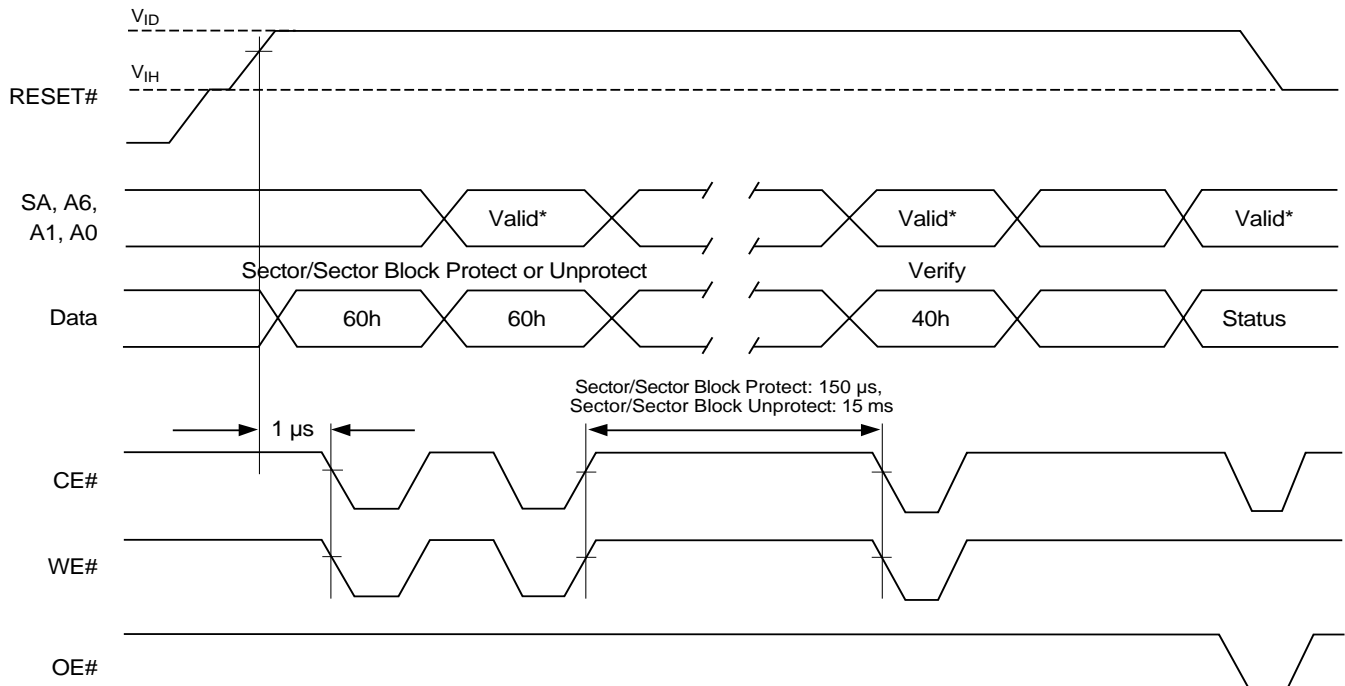

Figure 24. Accelerated Program Timing Diagram

AC CHARACTERISTICS



* For sector protect, A6 = 0, A1 = 1, A0 = 0. For sector unprotect, A6 = 1, A1 = 1, A0 = 0.

Figure 25. Sector/Block Protect and Unprotect Timing Diagram

AC CHARACTERISTICS

Alternate CE# Controlled Erase and Program Operations

Parameter		Description		90	120	Unit
JEDEC	Std.					
t_{AVAV}	t_{WC}	Write Cycle Time (Note 1)	Min	90	120	ns
t_{AVWL}	t_{AS}	Address Setup Time	Min	0		ns
t_{ELAX}	t_{AH}	Address Hold Time	Min	45	50	ns
t_{DVEH}	t_{DS}	Data Setup Time	Min	45	50	ns
t_{EHDX}	t_{DH}	Data Hold Time	Min	0		ns
t_{GHLEL}	t_{GHLEL}	Read Recovery Time Before Write (OE# High to WE# Low)	Min	0		ns
t_{WLEL}	t_{WS}	WE# Setup Time	Min	0		ns
t_{EHWH}	t_{WH}	WE# Hold Time	Min	0		ns
t_{ELEH}	t_{CP}	CE# Pulse Width	Min	45	50	ns
t_{EHEL}	t_{CPH}	CE# Pulse Width High	Min	30		ns
t_{WHWH1}	t_{WHWH1}	Programming Operation (Note 2)	Byte	Typ	9	μ s
			Word	Typ	11	
t_{WHWH1}	t_{WHWH1}	Accelerated Programming Operation, Word or Byte (Note 2)	Typ	7		μ s
t_{WHWH2}	t_{WHWH2}	Sector Erase Operation (Note 2)	Typ	0.7		sec

Notes:

1. Not 100% tested.
2. See "[Erase And Programming Performance](#)" on page 50 for more information.

AC CHARACTERISTICS

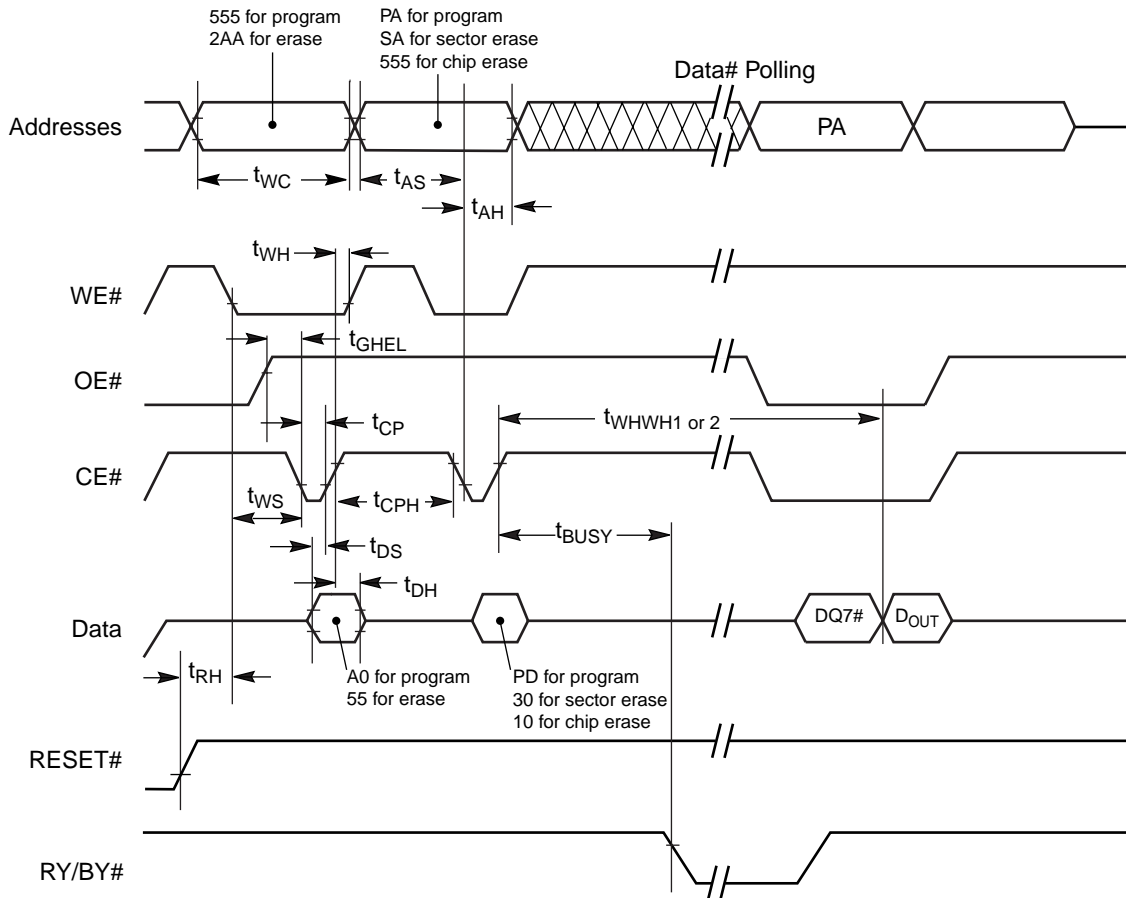

Notes:

1. Figure indicates last two bus cycles of a program or erase operation.
2. PA = program address, SA = sector address, PD = program data.
3. DQ7# is the complement of the data written to the device. D_{OUT} is the data written to the device.
4. Waveforms are for the word mode.

Figure 26. Alternate CE# Controlled Write (Erase/Program) Operation Timings

ERASE AND PROGRAMMING PERFORMANCE

Parameter	Typ (Note 1)	Max (Note 2)	Unit	Comments
Sector Erase Time	0.7	15	sec	Excludes 00h programming prior to erasure (Note 4)
Chip Erase Time	50		sec	
Byte Program Time	9	300	μ s	Excludes system level overhead (Note 5)
Word Program Time	11	360	μ s	
Accelerated Byte/Word Program Time	7	210	μ s	
Chip Program Time (Note 3)	Byte Mode	36	sec	
	Word Mode	24		

Notes:

1. Typical program and erase times assume the following conditions: 25°C, 3.0 V V_{CC} , 1,000,000 cycles. Additionally, programming typicals assume checkerboard pattern.
2. Under worst case conditions of 90°C, $V_{CC} = 2.7$ V, 1,000,000 cycles.
3. The typical chip programming time is considerably less than the maximum chip programming time listed, since most bytes program faster than the maximum program times listed.
4. In the pre-programming step of the Embedded Erase algorithm, all bytes are programmed to 00h before erasure.
5. System-level overhead is the time required to execute the two- or four-bus-cycle sequence for the program command. See [Table 14, on page 29](#) for further information on command definitions.
6. The device has a minimum erase and program cycle endurance of 1,000,000 cycles.

LATCHUP CHARACTERISTICS

Description	Min	Max
Input voltage with respect to V_{SS} on all pins except I/O pins (including A9, OE#, and RESET#)	-1.0 V	12.5 V
Input voltage with respect to V_{SS} on all I/O pins	-1.0 V	$V_{CC} + 1.0$ V
V_{CC} Current	-100 mA	+100 mA

Note: Includes all pins except V_{CC} . Test conditions: $V_{CC} = 3.0$ V, one pin at a time.

TSOP AND BGA PACKAGE CAPACITANCE

Parameter Symbol	Parameter Description	Test Setup	Typ	Max	Unit	
C_{IN}	Input Capacitance	$V_{IN} = 0$	TSOP	6	7.5	pF
			Fine-pitch BGA	4.2	5.0	pF
C_{OUT}	Output Capacitance	$V_{OUT} = 0$	TSOP	8.5	12	pF
			Fine-pitch BGA	5.4	6.5	pF
C_{IN2}	Control Pin Capacitance	$V_{IN} = 0$	TSOP	7.5	9	pF
			Fine-pitch BGA	3.9	4.7	pF

Notes:

1. Sampled, not 100% tested.
2. Test conditions $T_A = 25^\circ\text{C}$, $f = 1.0$ MHz.

DATA RETENTION

Parameter Description	Test Conditions	Min	Unit
Minimum Pattern Data Retention Time	150°C	10	Years
	125°C	20	Years

PHYSICAL DIMENSIONS

FBD048—48-ball Fine-Pitch Ball Grid Array (FBGA) 6 x 12 mm package

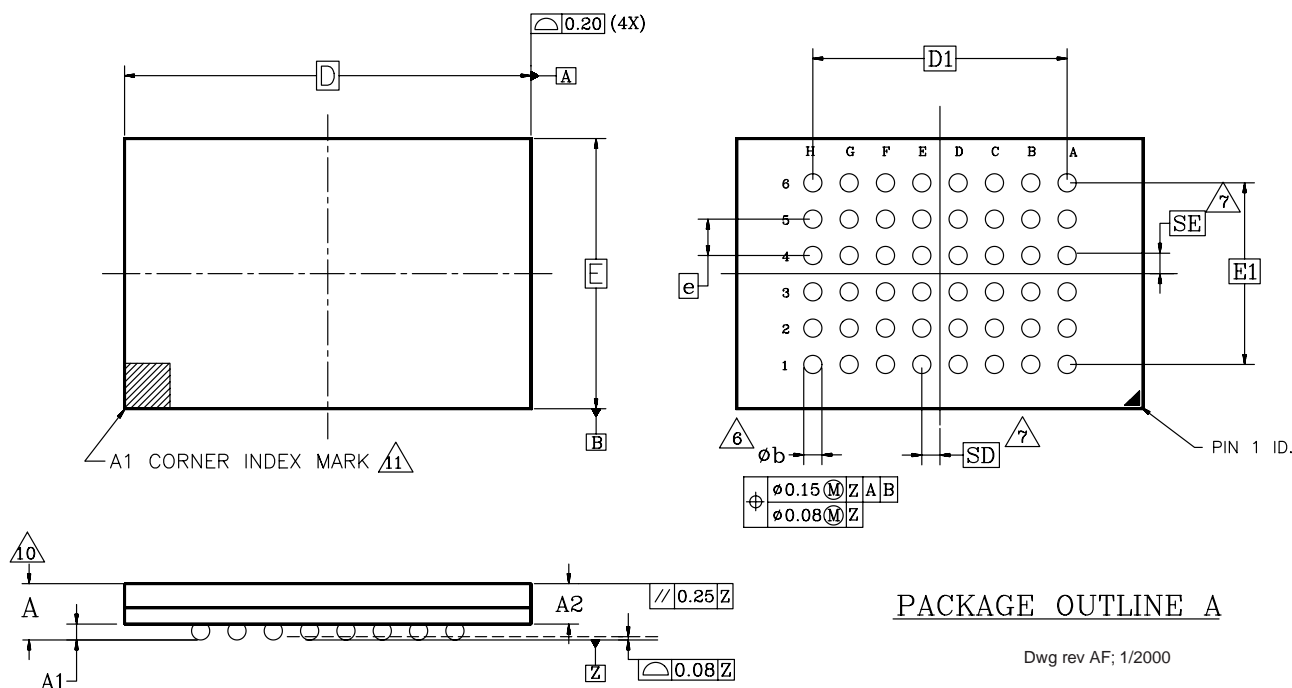

PACKAGE	xFBD 048			NOTE
JEDEC	N/A			
	6.00 mm x 12.00 mm PACKAGE			
SYMBOL	MIN	NOM	MAX	NOTE
A	—	—	1.20	OVERALL THICKNESS
A1	0.20	—	—	BALL HEIGHT
A2	0.84	—	0.94	BODY THICKNESS
\boxed{D}	12.00 BSC			BODY SIZE
\boxed{E}	6.00 BSC			BODY SIZE
$\boxed{D1}$	5.60 BSC			BALL FOOTPRINT
$\boxed{E1}$	4.00 BSC			BALL FOOTPRINT
MD	8			ROW MATRIX SIZE D DIRECTION
ME	6			ROW MATRIX SIZE E DIRECTION
N	48			TOTAL BALL COUNT
b	0.25	0.30	0.35	BALL DIAMETER
e	0.80 BSC			BALL PITCH
\boxed{SD}/\boxed{SE}	0.40 BSC			SOLDER BALL PLACEMENT

NOTES:

- DIMENSIONING AND TOLERANCING PER ASME Y14.5M-1994.
- ALL DIMENSIONS ARE IN MILLIMETERS.
- BALL POSITION DESIGNATION PER JESD 95-1, SPP-010.
- \boxed{e} REPRESENTS THE SOLDER BALL GRID PITCH.
- SYMBOL "MD" IS THE BALL ROW MATRIX SIZE IN THE "D" DIRECTION. SYMBOL "ME" IS THE BALL COLUMN MATRIX SIZE IN THE "E" DIRECTION. N IS THE MAXIMUM NUMBER OF SOLDER BALLS FOR MATRIX SIZE MD x ME.
- $\triangle 6$ DIMENSION "b" IS MEASURED AT THE MAXIMUM BALL DIAMETER IN A PLANE PARALLEL TO DATUM Z.
- $\triangle 7$ SD AND SE ARE MEASURED WITH RESPECT TO DATUMS A AND B AND DEFINE THE POSITION OF THE CENTER SOLDER BALL IN THE OUTER ROW. WHEN THERE IS AN ODD NUMBER OF SOLDER BALLS IN THE OUTER ROW PARALLEL TO THE D OR E DIMENSION, RESPECTIVELY, SD OR SE = 0.000 WHEN THERE IS AN EVEN NUMBER OF SOLDER BALLS IN THE OUTER ROW, SD OR SE = $\boxed{e/2}$
- "X" IN THE PACKAGE VARIATIONS DENOTES PART IS UNDER QUALIFICATION.
- "+" IN THE PACKAGE DRAWING INDICATE THE THEORETICAL CENTER OF DEPOPULATED BALLS.
- $\triangle 10$ FOR PACKAGE THICKNESS A IS THE CONTROLLING DIMENSION.
- $\triangle 11$ A1 CORNER TO BE IDENTIFIED BY CHAMFER, INK MARK, METALLIZED MARKINGS INDENTION OR OTHER MEANS.

PHYSICAL DIMENSIONS
TS 048—48-Pin Standard TSOP

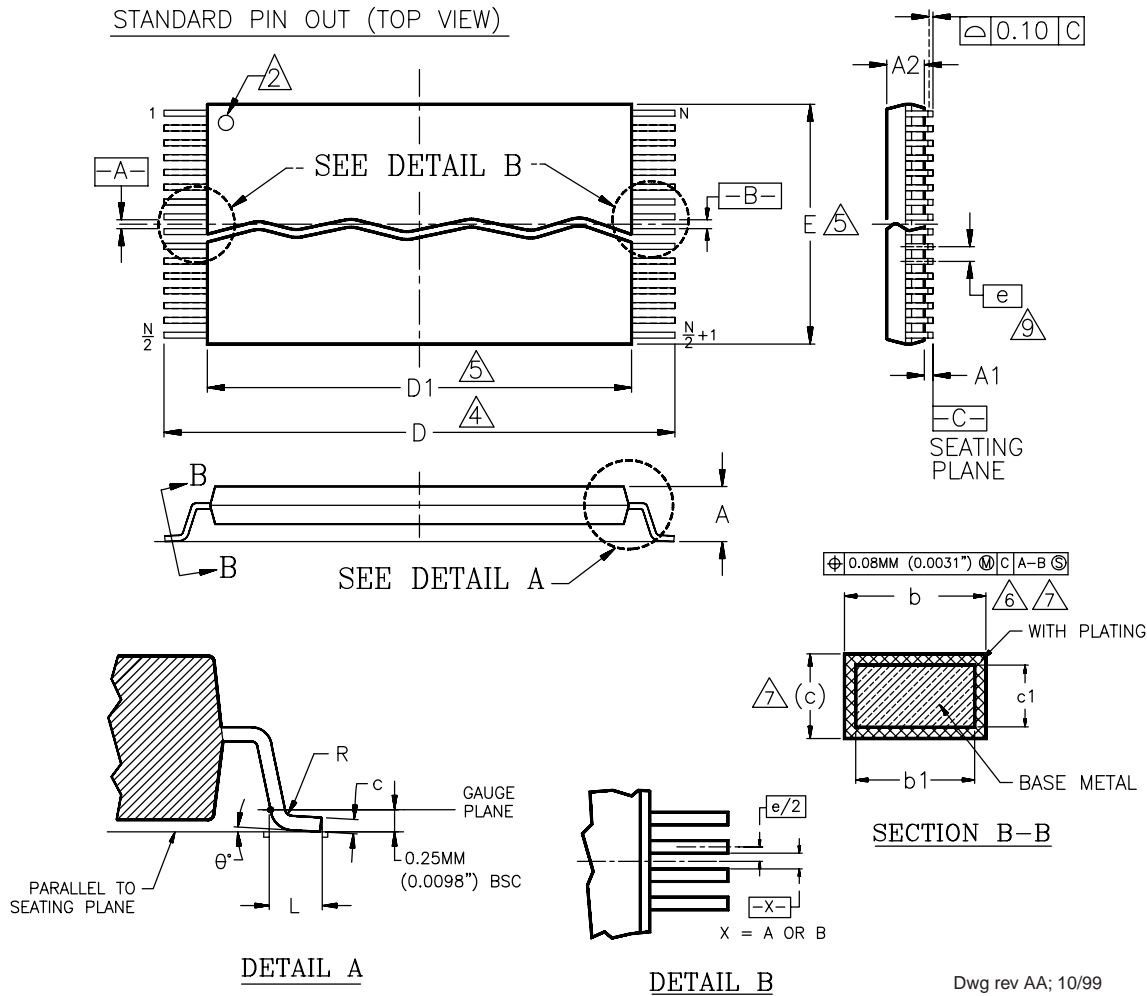

Dwg rev AA; 10/99

Package	TS 48		
Jedec	MO-142 (B) DD		
Symbol	MIN	NOM	MAX
A	—	—	1.20
A1	0.05	—	0.15
A2	0.95	1.00	1.05
b1	0.17	0.20	0.23
b	0.17	0.22	0.27
c1	0.10	—	0.16
c	0.10	—	0.21
D	19.80	20.00	20.20
D1	18.30	18.40	18.50
E	11.90	12.00	12.10
e	0.50 BASIC		
L	0.50	0.60	0.70
θ	0°	3°	5°
R	0.08	—	0.20
N	48		

NOTES:

1. CONTROLLING DIMENSIONS ARE IN MILLIMETERS (mm). (DIMENSIONING AND TOLERANCING CONFORMS TO ANSI Y14.5M-1982)
2. PIN 1 IDENTIFIER FOR STANDARD PIN OUT (DIE UP).
3. PIN 1 IDENTIFIER FOR REVERSE PIN OUT (DIE DOWN): INK OR LASER MARK.
4. TO BE DETERMINED AT THE SEATING PLANE [C]. THE SEATING PLANE IS DEFINED AS THE PLANE OF CONTACT THAT IS MADE WHEN THE PACKAGE LEADS ARE ALLOWED TO REST FREELY ON A FLAT HORIZONTAL SURFACE.
5. DIMENSIONS D1 AND E DO NOT INCLUDE MOLD PROTRUSION. ALLOWABLE MOLD PROTRUSION IS 0.15mm (0.0059") PER SIDE.
6. DIMENSION b DOES NOT INCLUDE DAMBAR PROTRUSION. ALLOWABLE DAMBAR PROTRUSION SHALL BE 0.08mm (0.0031") TOTAL IN EXCESS OF b DIMENSION AT MAX. MATERIAL CONDITION. MINIMUM SPACE BETWEEN PROTRUSION AND AN ADJACENT LEAD TO BE 0.07mm (0.0028").
7. THESE DIMENSIONS APPLY TO THE FLAT SECTION OF THE LEAD BETWEEN 0.10mm (0.0039") AND 0.25mm (0.0098") FROM THE LEAD TIP.
8. LEAD COPLANARITY SHALL BE WITHIN 0.10mm (0.004") AS MEASURED FROM THE SEATING PLANE.
9. DIMENSION "e" IS MEASURED AT THE CENTERLINE OF THE LEADS.

REVISION SUMMARY

Revision A (November 1, 2000)

Initial release.

Revision A+I (January 23, 2001)

Ordering Information

Corrected FBGA part number table to include bottom boot part numbers.

Revision A+2 (February 1, 2001)

Connection Diagrams

Corrected FBGA ball matrix.

Revision A+3 (July 2, 2001)

Global

Changed data sheet status from Advance Information to Preliminary.

[Table 3](#), Top Boot SecSi™ Sector Addresses

Corrected sector block size for SA60–SA62 to 3x64.

Sector/Sector Block Protection and Unprotection

Noted that sectors are erased in parallel.

SecSi™ Sector (Secured Silicon) Flash Memory Region

Noted changes for upcoming versions of these devices: reduced SecSi Sector size, different ESN location for top boot devices, and deletion of SecSi Sector erase functionality. Current versions of these devices remain unaffected.

Revision B (July 12, 2002)

Global

Deleted Preliminary status from document.

Ordering Information

Deleted burn-in option.

[Table 1](#), Am29LV320D Device Bus Operations

In the legend, corrected V_{HH} maximum voltage to 12.5 V.

SecSi™ Sector (Secured Silicon) Flash Memory Region

Added description of SecSi Sector protection verification.

Autoselect Command Sequence

Clarified description of function.

[Table 14](#), Am29LV320D Command Definitions

Corrected autoselect codes for SecSi Sector Factory Protect.

Erase and Program Operations table

Corrected to indicate t_{BUSY} specification is a maximum value.

Revision B+I (July 30, 2002)

[Figure 3](#), SecSi Sector Protect Verify

Deleted fifth block in flowchart and modified text in fourth block.

Revision C (October 25, 2002)

Distinctive Characteristics

Changed endurance from “write” to “erase” cycles.

Connection Diagrams

Deleted ultrasonic reference and added package types to special package handling text.

Ordering Information

Added commercial temperature range and removed extended temperature range.

SecSi Sector Flash Memory Region

Customer Lockable subsection: Deleted reference to alternate method of sector protection.

Command Definitions

Noted the following:

Autoselect, SecSi Sector, and CFI functions are not available during a program or erase operation.

ACC and unlock bypass modes are not available when the SecSi Sector is enabled.

Writing incorrect data or commands may place the device in an unknown state. A reset command is then required.

AC Characteristics

Read-only Operations; Word/Byte Configuration: Changed t_{DF} and t_{FLQZ} to 16 ns for all speed options.

DC Characteristics

Deleted I_{ACC} and added I_{LR} specifications from table.

TSOP, SO, and BGA Package Capacitance

Added BGA capacitance to table.

Revision C+1 (February 16, 2003)**Distinctive Characteristics**

Added reference to MirrorBit in Secured Silicon section.

Added Sector Architecture section.

SecSi Sector Flash Memory Region

Referenced MirrorBit for an example in last sentence of first paragraph.

Command Definitions

Changed the first address of the Unlock Bypass Reset from BA to XXX.

Erase and Programming Performance

Corrected the Sector Erase Time Typical to 0.7.

Revision C+2 (April 4, 2003)**Distinctive Characteristics**

Clarified reference to MirrorBit in Secured Silicon section.

SecSi Sector Flash Memory Region

Clarified reference of MirrorBit for an example in last sentence of first paragraph.

Revision C+3 (September 19, 2003)**Valid Combinations**

Added the 90R package to table.

Revision C+4 (April 5, 2004)**Command Definitions**

Changed first address data for Erase Suspend/Resume from BA to XXX.

Revision C+5 (June 4, 2004)**Ordering Information**

Added Lead-free (Pb-free) options to the temperature ranges breakout table and valid combinations table.

Product Selector Guide

Added 90R voltage range.

Revision C+6 (November 15, 2004)**Global**

Added Colophon

Updated Trademarks

Added reference links

Ordering Information

Added Automotive In-Cabin temperature range and associated part numbers in the valid combination table.

Erase and Programming Performance

Updated Chip Erase Time

AC Characteristics

Added t_{RH} line to Figure 15.

Erase and Program Operations

Corrected Sector Erase Operation time (t_{WHWH2})

Alternate CE# Control Erase and Program Operations

Corrected Sector Erase Operation time (t_{WHWH2})

Command Definitions

Update text in Sector Erase Command Sequence paragraph.

Colophon

The products described in this document are designed, developed and manufactured as contemplated for general use, including without limitation, ordinary industrial use, general office use, personal use, and household use, but are not designed, developed and manufactured as contemplated (1) for [any use that includes](#) fatal risks or dangers that, unless extremely high safety is secured, could have a serious effect to the public, and could lead directly to death, personal injury, severe physical damage or other loss (i.e., nuclear reaction control in nuclear facility, aircraft flight control, air traffic control, mass transport control, medical life support system, missile launch control in weapon system), or (2) [for any use where chance of failure is intolerable](#) (i.e., submersible repeater and artificial satellite). Please note that Spansion LLC will not be liable to you and/or any third party for any claims or damages arising in connection with above-mentioned uses of the products. Any semiconductor devices have an inherent chance of failure. You must protect against injury, damage or loss from such failures by incorporating safety design measures into your facility and equipment such as redundancy, fire protection, and prevention of over-current levels and other abnormal operating conditions. If any products described in this document represent goods or technologies subject to certain restrictions on export under the Foreign Exchange and Foreign Trade Law of Japan, [the US Export Administration Regulations](#) or [the applicable laws of any other country](#), the prior authorization by [the respective government entity](#) will be required for export of those products.

Trademarks

Copyright © 2000-**2004** Advanced Micro Devices, Inc. All rights reserved.

AMD, the AMD logo, and combinations thereof are registered trademarks of Advanced Micro Devices, Inc.

ExpressFlash is a trademark of Advanced Micro Devices, Inc.

Product names used in this publication are for identification purposes only and may be trademarks of their respective companies