

AD5015 SERIES

External Dimensions

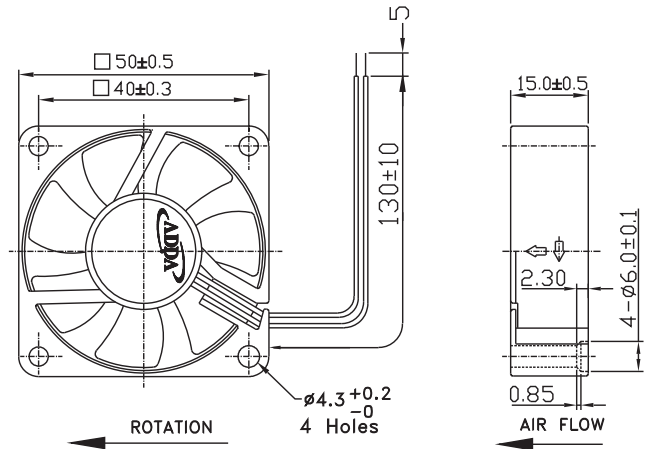
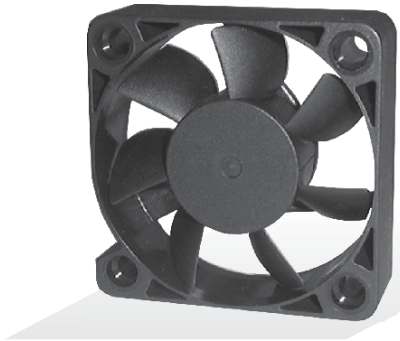

Frame: Plastic(UL:94V-0)
 Impeller: Plastic(UL:94V-0)
 Lead wire: UL1007AWG26

Specifications(Nominal)

*Noise is measured at the distance of one (1) meter from the axis of intake.

Bearing type: ⊙=Ball ※=Sleeve ○=1B1S ●=Hypro bearing

Frame size (mm)	Model No.	Bearing System Type	Rated Voltage (VDC)	Current (A)	Power (W)	Rated Speed (rpm)	Maximum AirFlow (CMM)	Maximum AirFlow (CFM)	Maximum Pressure (InAq)	Maximum Pressure (mmAq)	*Noise Level (dB/A)	Weight (g)
50x50x15	AD5005LB-D70(T1)	⊙ ※ ●	5	0.13	0.65	3600	0.311	11.000	0.070	1.778	25.0	27.0
	AD5005MB-D70(T1)	⊙ ※ ●	5	0.19	0.95	4300	0.367	13.000	0.100	2.540	30.0	
	AD5005HB-D71	⊙ ※ ●	5	0.21	1.05	4800	0.404	14.300	0.130	3.302	34.0	
	AD5012LB-D70(T1)	⊙ ※ ●	12	0.07	0.84	3600	0.311	11.000	0.070	1.778	25.0	
	AD5012MB-D70(T1)	⊙ ※ ●	12	0.08	0.96	4300	0.367	13.000	0.100	2.540	30.0	
	AD5012HB-D70(T1)	⊙ ※ ●	12	0.11	1.32	4800	0.404	14.300	0.130	3.302	34.0	
	AD5012UB-D70(T1)	⊙ ※ ●	12	0.14	1.68	5500	0.466	16.500	0.180	4.572	37.5	
	AD5024LB-D71	⊙ ※ ●	24	0.04	0.96	3600	0.311	11.000	0.070	1.778	25.0	
	AD5024MB-D71	⊙ ※ ●	24	0.05	1.20	4300	0.367	13.000	0.100	2.540	30.0	
	AD5024HB-D71	⊙ ※ ●	24	0.06	1.44	4800	0.404	14.300	0.130	3.302	34.0	
	AD5024UB-D71	⊙ ※ ●	24	0.08	1.90	5500	0.466	16.500	0.180	4.572	37.5	
	AD5024XB-D71	⊙ ※ ●	24	0.10	2.40	6300	0.534	18.900	0.200	5.080	39.1	
	AD5024VB-D71	⊙ ※ ●	24	0.12	2.88	7000	0.631	22.300	0.268	6.807	42.3	

Specifications subject to change without notice.

The specification for bearing type is for reference only, for more bearing types information, please contact with your ADDA sales representative, thanks!!
 (網頁上呈現產品軸承資訊均以2Ball為主, 若需其他產品資訊請聯絡您在ADDA的業務代表, 謝謝!!)

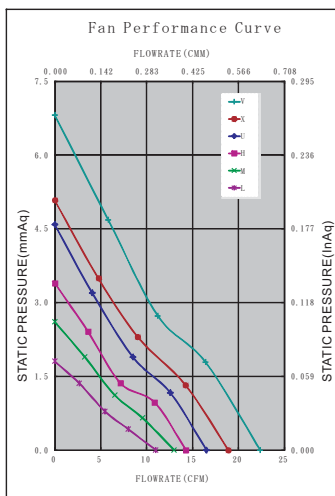

*Motor protective circuit and third lead wire functions

0	1	2	3	4	6	7	8	9	A	B
✓	✓	✓	✓		✓			✓		✓

*Safety approvals

✓	✓		✓	✓