

### FEATURES

#### Voltage feedback amplifier

Ideal for ADSL and ADSL2+ central office (CO) and customer premises equipment (CPE) applications

Enables high current differential applications

#### Low power operation

Single- or dual-supply operation from 10 V ( $\pm 5$  V) up to 24 V ( $\pm 12$  V)

5.5 mA total quiescent supply current for full power ADSL and ADSL2+ CO applications

Adjustable supply current to minimize power consumption

#### High output voltage and current drive

400 mA peak output drive current

44 V p-p differential output voltage

#### Low distortion

-70 dBc MTPR, 26 kHz to 1.1 MHz

-65 dBc MTPR, 1.1 MHz to 2.2 MHz

High speed: 260 V/ $\mu$ s differential slew rate

### APPLICATIONS

ADSL/ADSL2+ CO and CPE line drivers

xDSL line drivers

High current differential amplifiers

### GENERAL DESCRIPTION

The AD8390A is a high output current, low power consumption differential amplifier. It is particularly well suited for the central office (CO) driver interface in digital subscriber line systems such as ADSL and ADSL2+. In full bias operation, the driver delivers 20.4 dBm output power into low resistance loads while compensating for hybrid and transformer insertion losses and back termination resistors.

The AD8390A is available in a thermally enhanced LFCSP package (16-lead LFCSP). Significant control and flexibility in bias current have been designed into the AD8390A.

Four power modes are selectable via two digital inputs, PD0 and PD1, providing three levels of driver bias and one power-down state. In addition, the  $I_{ADJ}$  pin is available for fine quiescent current trimming to tailor the performance of the AD8390A.

The low power consumption, high output current, high output voltage swing, and robust thermal packaging enable the AD8390A to be used as the central office line driver in ADSL, ADSL2+, and proprietary xDSL systems, as well as in other high current applications requiring a differential amplifier.

### PIN CONFIGURATION

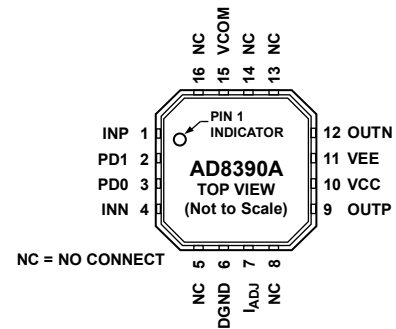

Figure 1. Thermally Enhanced, 4 mm  $\times$  4 mm 16-Lead LFCSP

### FUNCTIONAL BLOCK DIAGRAM

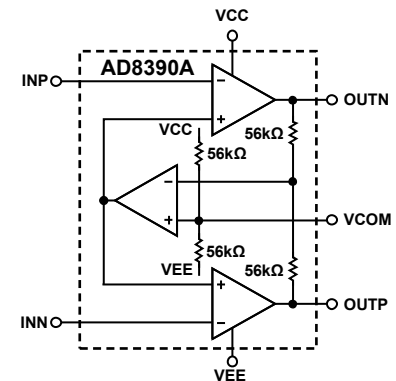

Figure 2.

For more information about the AD8390A, contact Analog Devices, Inc., at [Broadband.products@analog.com](mailto:Broadband.products@analog.com).

#### Rev. SpA

Information furnished by Analog Devices is believed to be accurate and reliable. However, no responsibility is assumed by Analog Devices for its use, nor for any infringements of patents or other rights of third parties that may result from its use. Specifications subject to change without notice. No license is granted by implication or otherwise under any patent or patent rights of Analog Devices. Trademarks and registered trademarks are the property of their respective owners.

**AD8390A**

**NOTES**