

FEATURES

- Pin programmable 2.5 V or 3.0 V output**
- Ultralow drift: 3 ppm/°C max**
- High accuracy: 2.5 V or 3.0 V ± 1 mV max**
- Low noise: 100 nV/ $\sqrt{\text{Hz}}$**
- Noise reduction capability**
- Low quiescent current: 1 mA max**
- Output trim capability**
- Plug-in upgrade for present references**
- Temperature output pin**
- Series or shunt mode operation (± 2.5 V, ± 3.0 V)**

FUNCTIONAL BLOCK DIAGRAM

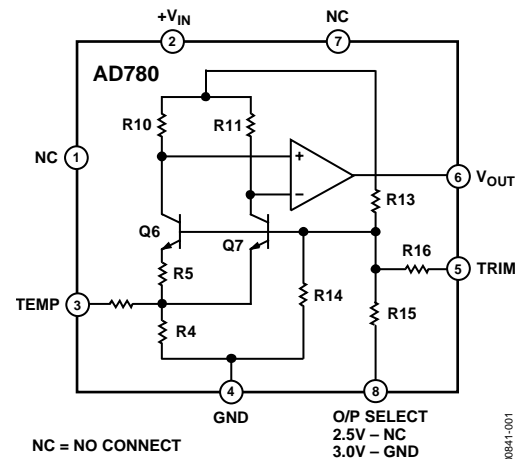

Figure 1.

PRODUCT DESCRIPTION

The AD780 is an ultrahigh precision band gap reference voltage that provides a 2.5 V or 3.0 V output from inputs between 4.0 V and 36 V. Low initial error and temperature drift combined with low output noise and the ability to drive any value of capacitance make the AD780 the ideal choice for enhancing the performance of high resolution ADCs and DACs, and for any general-purpose precision reference application. A unique low headroom design facilitates a 3.0 V output from a 5.0 V 10% input, providing a 20% boost to the dynamic range of an ADC over performance with existing 2.5 V references.

The AD780 can be used to source or sink up to 10 mA, and can be used in series or shunt mode, thus allowing positive or negative output voltages without external components. This makes it suitable for virtually any high performance reference application. Unlike some competing references, the AD780 has no region of possible instability. The part is stable under all load conditions when a 1 μF bypass capacitor is used on the supply.

A temperature output pin on the AD780 provides an output voltage that varies linearly with temperature, allowing the part to be configured as a temperature transducer while providing a stable 2.5 V or 3.0 V output.

Rev. E

Information furnished by Analog Devices is believed to be accurate and reliable. However, no responsibility is assumed by Analog Devices for its use, nor for any infringements of patents or other rights of third parties that may result from its use. Specifications subject to change without notice. No license is granted by implication or otherwise under any patent or patent rights of Analog Devices. Trademarks and registered trademarks are the property of their respective owners.

The AD780 is a pin compatible performance upgrade for the LT1019(A)-2.5 and the AD680. The latter is targeted toward low power applications.

The AD780 is available in three grades in PDIP and SOIC packages. The AD780AN, AD780AR, AD780BN, AD780BR, and AD780CR are specified for operation from -40°C to $+85^{\circ}\text{C}$.

PRODUCT HIGHLIGHTS

1. The AD780 provides a pin programmable 2.5 V or 3.0 V output from a 4 V to 36 V input.
2. Laser trimming of both initial accuracy and temperature coefficients results in low errors over temperature without the use of external components. The AD780BN has a maximum variation of 0.9 mV from -40°C to $+85^{\circ}\text{C}$.
3. For applications that require even higher accuracy, an optional fine-trim connection is provided.
4. The AD780 noise is extremely low, typically 4 mV p-p from 0.1 Hz to 10 Hz and a wideband spectral noise density of typically 100 nV/ $\sqrt{\text{Hz}}$. This can be further reduced, if desired, by using two external capacitors.
5. The temperature output pin enables the AD780 to be configured as a temperature transducer while providing a stable output reference.

TABLE OF CONTENTS

Specifications.....	3	Supply Current Over Temperature	8
Absolute Maximum Ratings.....	4	Turn-On Time	8
Notes.....	4	Dynamic Performance.....	8
ESD Caution.....	4	Line Regulation.....	9
Theory of Operation	5	Precision Reference for High Resolution 5 V Data Converters	9
Applying the AD780.....	6	4.5 V Reference from 5 V Supply	10
Noise Performance	6	Negative (–2.5 V) Reference	10
Noise Comparison.....	7	Outline Dimensions	11
Temperature Performance.....	7	Ordering Guide.....	12
Temperature Output Pin	7		
Temperature Transducer Circuit.....	8		

REVISION HISTORY**5/04—Data Sheet Changed from Rev. D to Rev. E**

Updated Format	Universal
Changes to Temperature Transducer Circuit section	8
Changes to Ordering Guide	12

1/04—Data Sheet Changed from Rev. C to Rev. D.

Changes to SPECIFICATIONS.....	2
Updated ORDERING GUIDE.....	3
Updated OUTLINE DIMENSIONS	10

5/02—Data Sheet Changed from Rev. B to Rev. C.

Updates to packages	10
---------------------------	----

SPECIFICATIONS

$T_A = 25^\circ\text{C}$, $V_{IN} = 5\text{ V}$, unless otherwise noted.

Table 1.

Parameter	AD780AN/AD780AR			AD780CR			AD780BN/AD780BR			Unit
	Min	Typ	Max	Min	Typ	Max	Min	Typ	Max	
OUTPUT VOLTAGE										
2.5 V Out	2.495		2.505	2.4985		2.5015	2.499		2.501	V
3.0 V Out	2.995		3.005	2.9950		3.0050	2.999		3.001	V
OUTPUT VOLTAGE DRIFT ¹										
-40°C to $+85^\circ\text{C}$			7			7			3	ppm/ $^\circ\text{C}$
-55°C to $+125^\circ\text{C}$			20			20				ppm/ $^\circ\text{C}$
LINE REGULATION										
2.5 V Output, $4\text{ V} \leq V_{IN} \leq 36\text{ V}$, T_{MIN} to T_{MAX}			10			10			10	$\mu\text{V}/\text{V}$
3.0 V Output, $4.5\text{ V} \leq V_{IN} \leq 36\text{ V}$, T_{MIN} to T_{MAX}			10			10			10	$\mu\text{V}/\text{V}$
LOAD REGULATION, SERIES MODE										
Sourcing $0\text{ mA} < I_{OUT} < 10\text{ mA}$			50			50			50	$\mu\text{V}/\text{mA}$
T_{MIN} to T_{MAX}			75			75			75	$\mu\text{V}/\text{mA}$
Sinking $-10\text{ mA} < I_{OUT} < 0\text{ mA}$			75			75			75	$\mu\text{V}/\text{mA}$
-40°C to $+85^\circ\text{C}$			75			75			75	$\mu\text{V}/\text{mA}$
-55°C to $+125^\circ\text{C}$			150			150			150	$\mu\text{V}/\text{mA}$
LOAD REGULATION, SHUNT MODE										
$I < I_{SHUNT} < 10\text{ mA}$			75			75			75	$\mu\text{V}/\text{mA}$
QUIESCENT CURRENT, 2.5 V SERIES MODE ²										
-40°C to $+85^\circ\text{C}$		0.75	1.0		0.75	1.0		0.75	1.0	mA
-55°C to $+125^\circ\text{C}$		0.8	1.3		0.8	1.3		0.8	1.3	mA
MINIMUM SHUNT CURRENT		0.7	1.0		0.7	1.0		0.7	1.0	mA
OUTPUT NOISE										
0.1 Hz to 10 Hz		4			4			4		$\mu\text{V p-p}$
Spectral Density, 100 Hz		100			100			100		$\text{nV}/\sqrt{\text{Hz}}$
LONG-TERM STABILITY ³		20			20			20		$\pm\text{ ppm}/1000\text{ Hr}$
TRIM RANGE	4.0			4.0			4.0			$\pm\%$
TEMPERATURE PIN										
Voltage Output @ 25°C	500	560	620	500	560	620	500	560	620	mV
Temperature Sensitivity		1.9			1.9			1.9		$\text{mV}/^\circ\text{C}$
Output Resistance		3			3			3		$\text{k}\Omega$
SHORT-CIRCUIT CURRENT TO GROUND		30			30			30		mA
TEMPERATURE RANGE										
Specified Performance (A, B, C)	-40		+85	-40		+85	-40		+85	$^\circ\text{C}$
Operating Performance (A, B, C) ⁴	-55		+125	-55		+125	-55		+125	$^\circ\text{C}$

¹ Maximum output voltage drift is guaranteed for all packages.

² 3.0 V mode typically adds 100 μA to the quiescent current. Also, I_q increases by 2 $\mu\text{A}/\text{V}$ above an input voltage of 5 V.

³ The long-term stability specification is noncumulative. The drift in subsequent 1,000 hour periods is significantly lower than in the first 1,000 hour period.

⁴ The operating temperature range is defined as the temperature extremes at which the device will still function. Parts may deviate from their specified performance outside their specified temperature range.

AD780

ABSOLUTE MAXIMUM RATINGS

Table 2.

Parameter	Values
+V _{IN} to Ground	36 V
TRIM Pin to Ground	36 V
TEMP Pin to Ground	36 V
Power Dissipation (25°C)	500 mW
Storage Temperature	-65°C to +150°C
Lead Temperature (Soldering 10 sec)	300°C
Output Protection	Output safe for indefinite short to ground and momentary short to V _{IN} .
ESD Classification	Class 1 (1000 V)

Stresses above those listed under Absolute Maximum Ratings may cause permanent damage to the device. This is a stress rating only; functional operation of the device at these or any conditions above those indicated in the operational sections of this specification is not implied. Exposure to absolute maximum specifications for extended periods may affect device reliability.

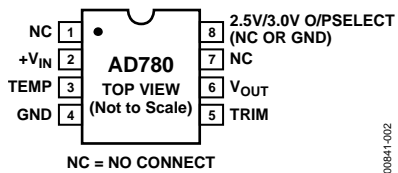

Figure 2. Pin Configuration, 8-Lead PDIP and SOIC Packages

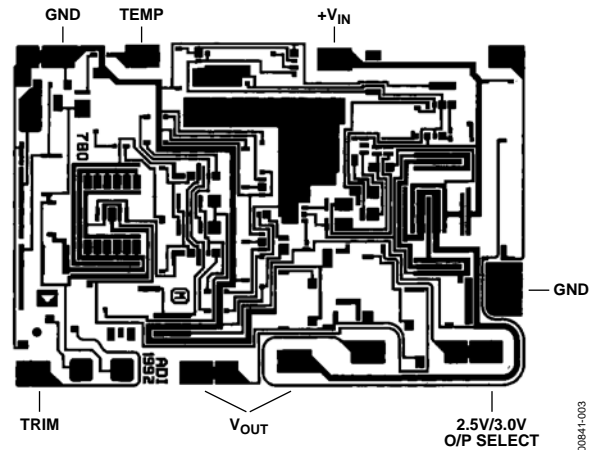

Figure 3. Die Layout

NOTES

Both V_{OUT} pads should be connected to the output.

Die Thickness: The standard thickness of Analog Devices bipolar dice is 24 mil ± 2 mil.

Die Dimensions: The dimensions given have a tolerance of ±2 mil.

Backing: The standard backside surface is silicon (not plated). Analog Devices does not recommend gold-backed dice for most applications.

Edges: A diamond saw is used to separate wafers into dice, thus providing perpendicular edges halfway through the die. In contrast to scribed dice, this technique provides a more uniform die shape and size. The perpendicular edges facilitate handling (such as tweezer pickup), while the uniform shape and size simplify substrate design and die attach.

Top Surface: The standard top surface of the die is covered by a layer of glassivation. All areas are covered except bonding pads and scribe lines.

Surface Metallization: The metallization to Analog Devices bipolar dice is aluminum. Minimum thickness is 10,000 Å.

Bonding Pads: All bonding pads have a minimum size of 4.0 mil by 6.0 mil. The passivation windows have a minimum size of 3.6 mil by 5.6 mil.

ESD CAUTION

ESD (electrostatic discharge) sensitive device. Electrostatic charges as high as 4000 V readily accumulate on the human body and test equipment and can discharge without detection. Although this product features proprietary ESD protection circuitry, permanent damage may occur on devices subjected to high energy electrostatic discharges. Therefore, proper ESD precautions are recommended to avoid performance degradation or loss of functionality.



THEORY OF OPERATION

Band gap references are the high performance solution for low supply voltage and low power voltage reference applications. In this technique, a voltage with a positive temperature coefficient is combined with the negative coefficient of a transistor's V_{be} to produce a constant band gap voltage.

In the AD780, the band gap cell contains two NPN transistors (Q6 and Q7) that differ in emitter area by $12\times$. The difference in their V_{be} s produces a PTAT current in R5. This, in turn, produces a PTAT voltage across R4 that, when combined with the V_{be} of Q7, produces a voltage (V_{bg}) that does not vary with temperature. Precision laser trimming of the resistors and other patented circuit techniques are used to further enhance the drift performance.

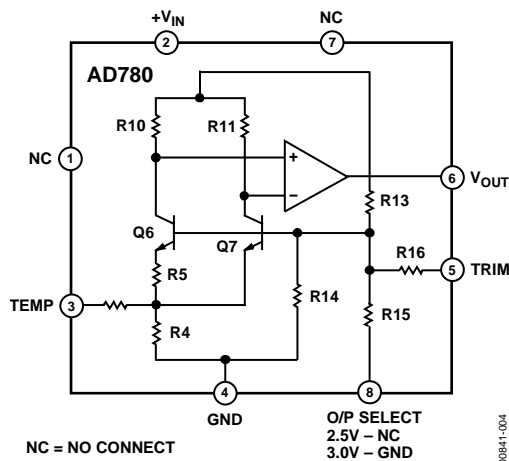

Figure 4. Schematic Diagram

The output voltage of the AD780 is determined by the configuration of Resistors R13, R14, and R15 in the amplifier's feedback loop. This sets the output to either 2.5 V or 3.0 V, depending on whether R15 (Pin 8) is grounded or not connected.

A unique feature of the AD780 is the low headroom design of the high gain amplifier, which produces a precision 3 V output from an input voltage as low as 4.5 V (or 2.5 V from a 4.0 V input). The amplifier design also allows the part to work with $+V_{IN} = V_{OUT}$ when current is forced into the output terminal. This allows the AD780 to work as a 2-terminal shunt regulator, providing a -2.5 V or -3.0 V reference voltage output without external components.

The PTAT voltage is also used to provide the user with a thermometer output voltage (at Pin 3) that increases at a rate of approximately 2 mV/ $^{\circ}$ C.

The AD780's NC (Pin 7) is a 20 k Ω resistor to $+V_{IN}$ that is used solely for production test purposes. Users who are currently using the LT1019 self-heater pin (Pin 7) must take into account the different load on the heater supply.

APPLYING THE AD780

The AD780 can be used without any external components to achieve specified performance. If power is supplied to Pin 2 and Pin 4 is grounded, Pin 6 provides a 2.5 V or 3.0 V output depending on whether Pin 8 is left unconnected or grounded.

A bypass capacitor of 1 μF (+V_{IN} to GND) should be used if the load capacitance in the application is expected to be greater than 1 nF. The AD780 in 2.5 V mode typically draws 700 μA of I_q at 5 V. This increases by $\sim 2 \mu\text{A}/\text{V}$ up to 36 V.

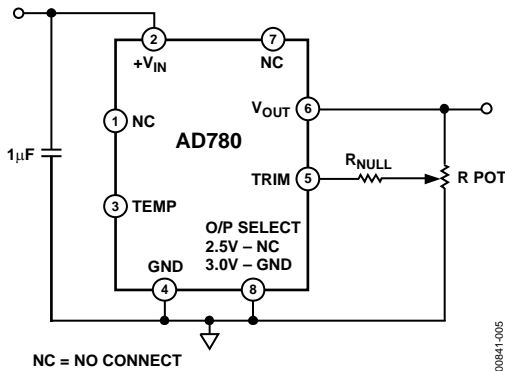

Figure 5. Optional Fine-Trim Circuit

Initial error can be nulled using a single 25 k Ω potentiometer connected between V_{OUT}, TRIM, and GND. This is a coarse trim with an adjustment range of 4%, and is only included here for compatibility purposes with other references. A fine trim can be implemented by inserting a large value resistor (e.g., 1 M Ω to 5 M Ω) in series with the wiper of the potentiometer (see Figure 5). The trim range, expressed as a fraction of the output, is simply greater than or equal to $2.1 \text{ k}\Omega / R_{\text{NULL}}$ for either the 2.5 V or 3.0 V mode.

The external null resistor affects the overall temperature coefficient by a factor equal to the percentage of V_{OUT} nulled.

For example, a 1 mV (0.03%) shift in the output caused by the trim circuit, with a 100 ppm/ $^{\circ}\text{C}$ null resistor, adds less than 0.06 ppm/ $^{\circ}\text{C}$ to the output drift ($0.03\% \times 200 \text{ ppm}/^{\circ}\text{C}$, since the resistors internal to the AD780 also have temperature coefficients of less than 100 ppm/ $^{\circ}\text{C}$).

NOISE PERFORMANCE

The impressive noise performance of the AD780 can be further improved, if desired, by adding two capacitors: a load capacitor (C1) between the output and ground, and a compensation capacitor (C2) between the TEMP pin and ground. Suitable values are shown in Figure 6.

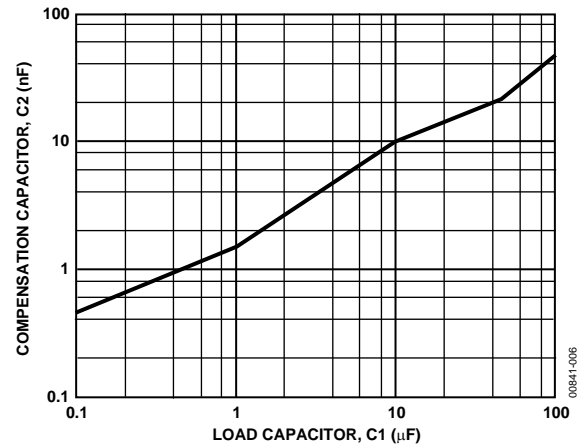

Figure 6. Compensation and Load Capacitor Combinations

C1 and C2 also improve the settling performance of the AD780 when subjected to load transients. The improvement in noise performance is shown in Figure 7, Figure 8, Figure 9, and Figure 10.

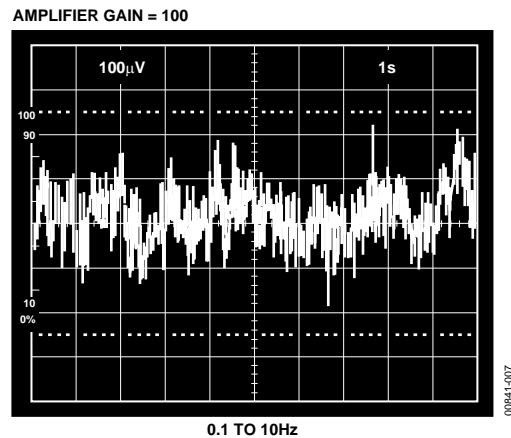

Figure 7. Standalone Noise Performance

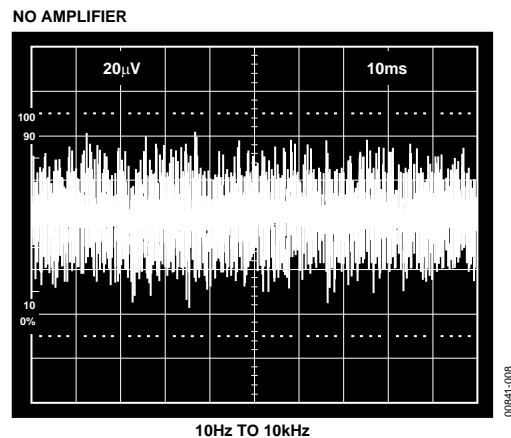

Figure 8. Standalone Noise Performance

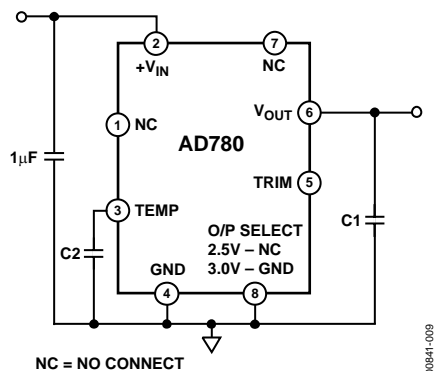

Figure 9. Noise Reduction Circuit

NOISE COMPARISON

The wideband noise performance of the AD780 can also be expressed in ppm. The typical performance with C1 and C2 is 0.6 ppm; without external capacitors, typical performance is 1.2 ppm.

This performance is, respectively, 7× and 3× lower than the specified performance of the LT1019.

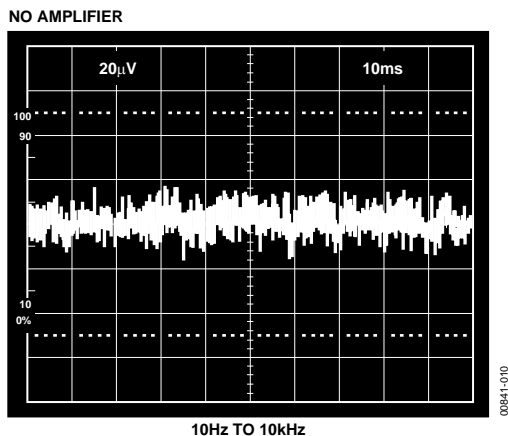

Figure 10. Reduced Noise Performance with C1 = 100 µF, C2 = 100 nF

TEMPERATURE PERFORMANCE

The AD780 provides superior performance over temperature by means of a combination of patented circuit design techniques, precision thin-film resistors, and drift trimming. Temperature performance is specified in terms of ppm/°C; because of nonlinearity in the temperature characteristic, the box test method is used to test and specify the part. The nonlinearity takes the form of the characteristic S-shaped curve shown in Figure 11. The box test method forms a rectangular box around this curve, enclosing the maximum and minimum output voltages over the specified temperature range. The specified drift is equal to the slope of the diagonal of this box.

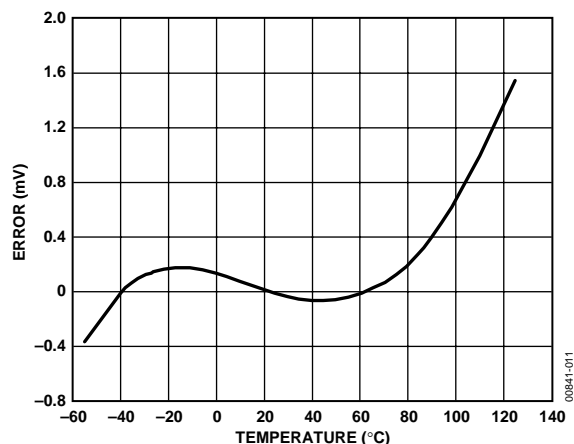

Figure 11. Typical AD780BN Temperature Drift

TEMPERATURE OUTPUT PIN

The AD780 provides a TEMP output (Pin 3) that varies linearly with temperature. This output can be used to monitor changes in system ambient temperature, and to initiate calibration of the system, if desired. The voltage V_{TEMP} is 560 mV at 25°C, and the temperature coefficient is approximately 2 mV/°C.

Figure 12 shows the typical V_{TEMP} characteristic curve over temperature taken at the output of the op amp with a noninverting gain of 5.

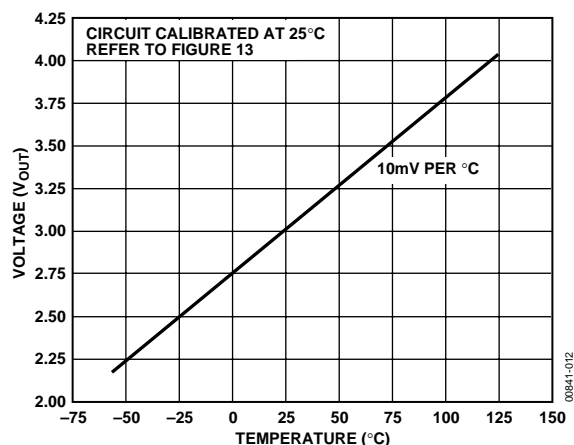

Figure 12. Temperature Pin Transfer Characteristic

Since the TEMP voltage is acquired from the band gap core circuit, current pulled from this pin has a significant effect on V_{OUT} . Care must be taken to buffer the TEMP output with a suitable op amp, e.g., an OP07, AD820, or AD711 (all of which would result in less than a 100 µV change in V_{OUT}). The relationship between I_{TEMP} and V_{OUT} is

$$\Delta V_{OUT} = 5.8 \text{ mV}/\mu\text{A } I_{TEMP} \text{ (2.5 V Range)}$$

or

$$\Delta V_{OUT} = 6.9 \text{ mV}/\mu\text{A } I_{TEMP} \text{ (3.0 V Range)}$$

AD780

Notice how sensitive the current dependent factor on V_{OUT} is. A large amount of current, even in tens of microamp, drawn from the TEMP pin can cause the V_{OUT} and TEMP output to fail.

The choice of C1 and C2 was dictated primarily by the need for a relatively flat response that rolled off early in the high frequency noise at the output. However, there is considerable margin in the choice of these capacitors. For example, the user can actually put a huge C2 on the TEMP pin with none on the output pin. However, one must either put very little or a lot of capacitance at the TEMP pin. Intermediate values of capacitance can sometimes cause oscillation. In any case, the user should follow the recommendation in Figure 6.

TEMPERATURE TRANSDUCER CIRCUIT

The circuit shown in Figure 13 is a temperature transducer that amplifies the TEMP output voltage by a gain of a little over +5 to provide a wider full-scale output range. The digital potentiometer can be used to adjust the output so it varies by exactly $10 \text{ mV}/^\circ\text{C}$.

To minimize resistance changes with temperature, resistors with low temperature coefficients, such as metal film resistors, should be used.

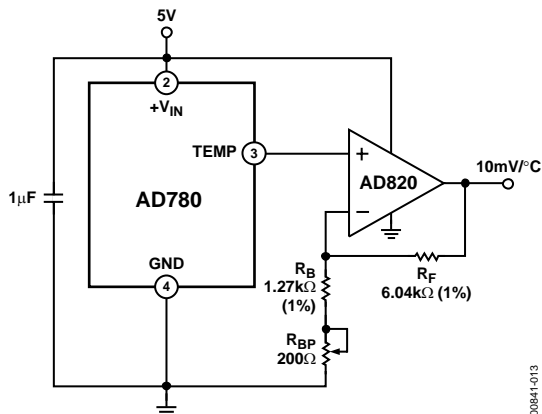

Figure 13. Differential Temperature Transducer

SUPPLY CURRENT OVER TEMPERATURE

The AD780's quiescent current varies slightly over temperature and input supply range. The test limit is 1 mA over the industrial and 1.3 mA over the military temperature range. Typical performance with input voltage and temperature variation is shown in Figure 14.

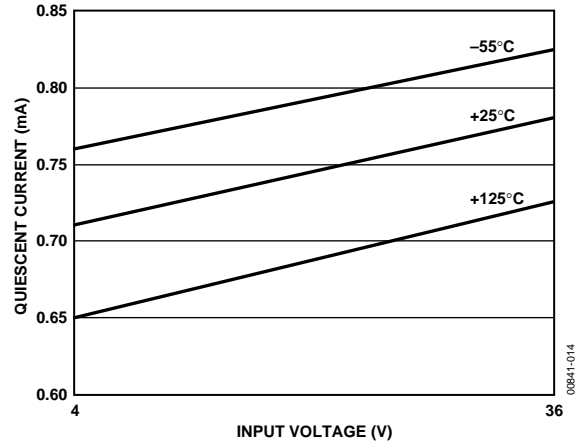

Figure 14. Typical Supply Current over Temperature

TURN-ON TIME

The time required for the output voltage to reach its final value within a specified error band is defined as the turn-on settling time. The two major factors that affect this are the active circuit settling time and the time for the thermal gradients on the chip to stabilize. Typical settling performance is shown in Figure 15. The AD780 settles to within 0.1% of its final value within $10 \mu\text{s}$.

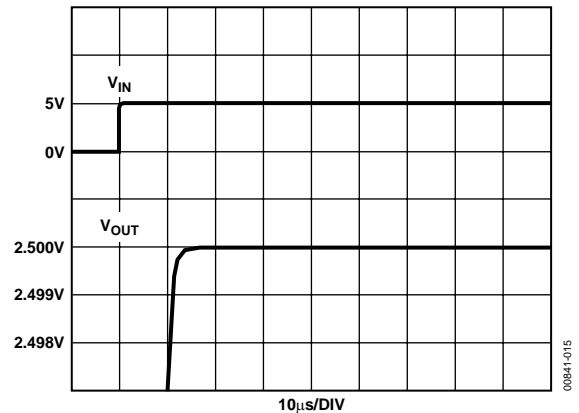

Figure 15. Turn-On Settling Time Performance

DYNAMIC PERFORMANCE

The output stage of the AD780 has been designed to provide superior static and dynamic load regulation.

Figure 16 and Figure 17 show the performance of the AD780 while driving a 0 mA to 10 mA load.

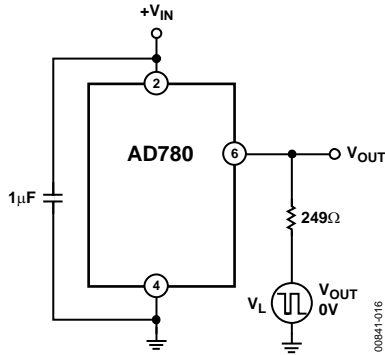

Figure 16. Transient Resistive Load Test Circuit

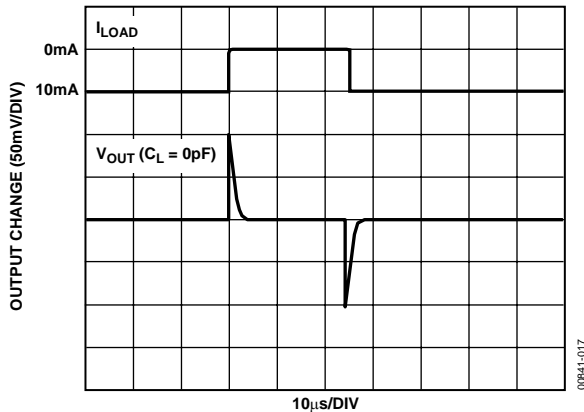

Figure 17. Settling under Transient Resistive Load

The dynamic load may be resistive and capacitive. For example, the load may be connected via a long capacitive cable. Figure 18 and Figure 19 show the performance of the AD780 driving a 1000 pF, 0 mA to 10 mA load.

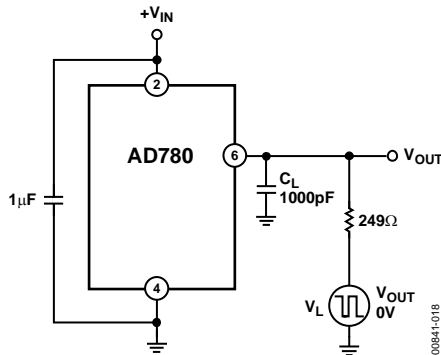

Figure 18. Capacitive Load Transient Response Test Circuit

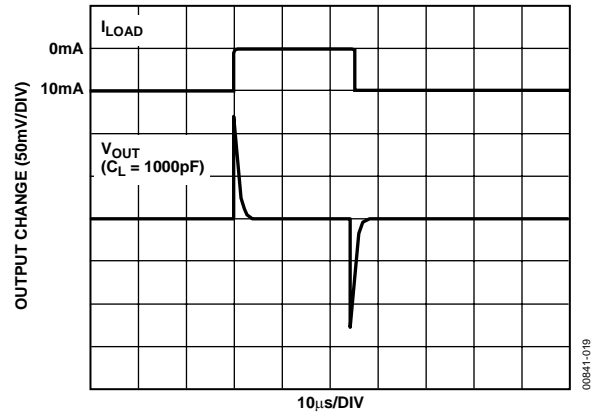

Figure 19. Settling under Dynamic Capacitive Load

LINE REGULATION

Line regulation is a measure of change in output voltage due to a specified change in input voltage. It is intended to simulate worst-case unregulated supply conditions and is measured in $\mu\text{V}/\text{V}$. Figure 20 shows typical performance with $4.0\text{ V} < V_{\text{IN}} < 15.0\text{ V}$.

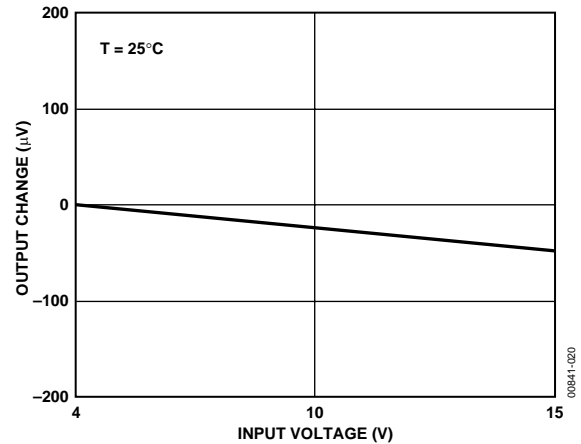

Figure 20. Output Voltage Change vs. Input Voltage

PRECISION REFERENCE FOR HIGH RESOLUTION 5 V DATA CONVERTERS

The AD780 is ideally suited to be the reference for most 5 V high resolution ADCs. The AD780 is stable under any capacitive load, has superior dynamic load performance, and its 3.0 V output provides the converter with the maximum dynamic range without requiring an additional and expensive buffer amplifier. One of the many ADCs that the AD780 is suited for is the AD7884, a 16-bit, high speed sampling ADC (see Figure 21). This part previously needed a precision 5 V reference, resistor divider, and buffer amplifier to do this function.

AD780

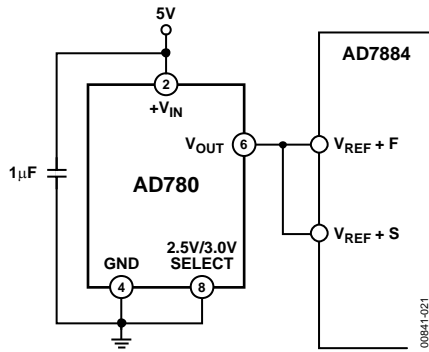

Figure 21. Precision 3 V Reference for the AD7884 16-Bit, High Speed ADC

The AD780 is also ideal for use with higher resolution converters, such as the AD7710/AD7711/AD7712 (see Figure 22). While these parts are specified with a 2.5 V internal reference, the AD780 in 3 V mode can be used to improve the absolute accuracy, temperature stability, and dynamic range. It is shown in Figure 22 with the two optional noise reduction capacitors.

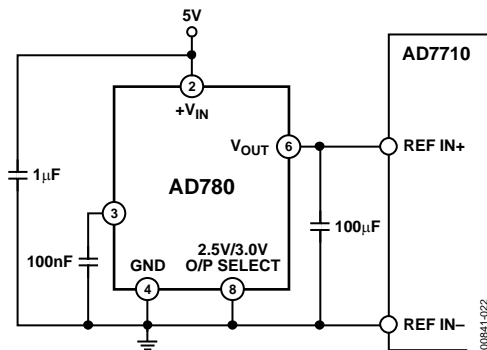

Figure 22. Precision 2.5 V or 3.0 V Reference for the AD7710 High Resolution, Σ - Δ ADC

4.5 V REFERENCE FROM 5 V SUPPLY

Some 5 V high resolution ADCs can accommodate reference voltages up to 4.5 V. The AD780 can be used to provide a precision 4.5 V reference voltage from a 5 V supply using the circuit shown in Figure 23. This circuit provides a regulated 4.5 V output from a supply voltage as low as 4.7 V. The high quality tantalum 10 μ F capacitor, in parallel with the ceramic AD780 0.1 μ F capacitor and the 3.9 Ω resistor, ensures a low output impedance around 50 MHz.

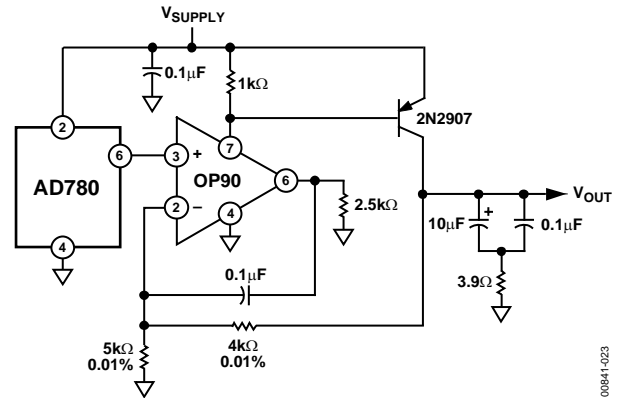

Figure 23. 4.5 V Reference from a Single 5 V Supply

NEGATIVE (-2.5 V) REFERENCE

The AD780 can produce a negative output voltage in shunt mode by connecting the input and output to ground, and connecting the AD780's GND pin to a negative supply via a bias resistor, as shown in Figure 25.

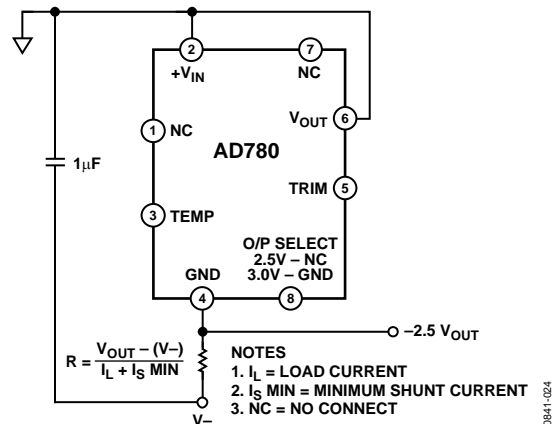

Figure 24. Negative (-2.5 V Shunt Mode Reference)

A precise -2.5 V reference capable of supplying up to 100 mA to a load can be implemented with the AD780 in series mode, using the bootstrap circuit shown in Figure 25.

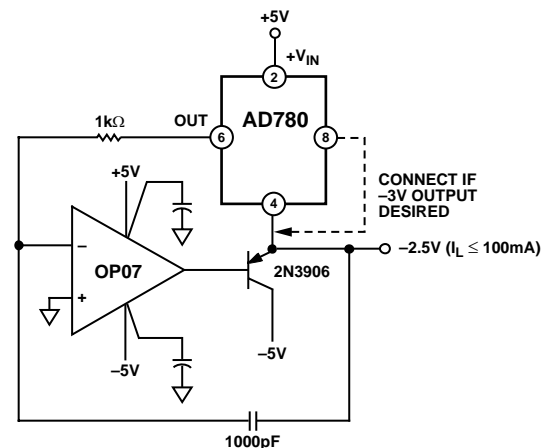
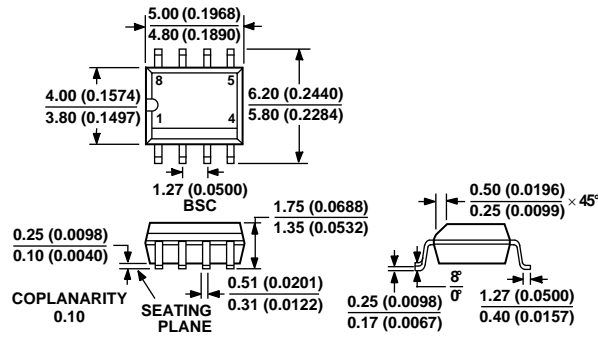

Figure 25. -2.5 V High Load Current Reference

OUTLINE DIMENSIONS



COMPLIANT TO JEDEC STANDARDS MS-012AA
CONTROLLING DIMENSIONS ARE IN MILLIMETERS; INCH DIMENSIONS (IN PARENTHESES) ARE ROUNDED-OFF MILLIMETER EQUIVALENTS FOR REFERENCE ONLY AND ARE NOT APPROPRIATE FOR USE IN DESIGN

Figure 26. 8-Lead Standard Small Outline Package [SOIC]
Narrow Body (R-8)
Dimensions shown in millimeters and (inches)

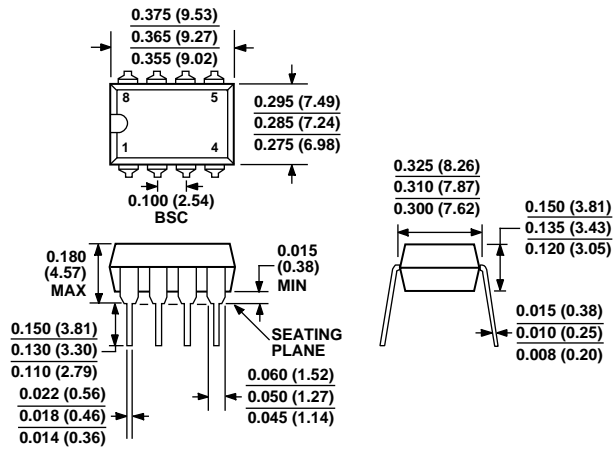

COMPLIANT TO JEDEC STANDARDS MO-095AA
CONTROLLING DIMENSIONS ARE IN INCHES; MILLIMETER DIMENSIONS (IN PARENTHESES) ARE ROUNDED-OFF INCH EQUIVALENTS FOR REFERENCE ONLY AND ARE NOT APPROPRIATE FOR USE IN DESIGN

Figure 27. 8-Lead Plastic Dual-In-Line Package [PDIP]
(N-8)
Dimensions shown in inches and (millimeters)

AD780

ORDERING GUIDE

Model	Initial Error	Temperature Range	Temperature Coefficient	Package Option	Qty. per Tube/Reel
AD780AN	±5.0 mV	−40°C to +85°C	7 ppm/°C	PDIP	48
AD780AR	±5.0 mV	−40°C to +85°C	7 ppm/°C	SOIC	98
AD780AR-REEL7	±5.0 mV	−40°C to +85°C	7 ppm/°C	SOIC	750
AD780ARZ ¹	±5.0 mV	−40°C to +85°C	7 ppm/°C	SOIC	98
AD780BN	±1.0 mV	−40°C to +85°C	3 ppm/°C	PDIP	48
AD780BR	±1.0 mV	−40°C to +85°C	3 ppm/°C	SOIC	98
AD780BRZ ¹	±1.0 mV	−40°C to +85°C	3 ppm/°C	SOIC	98
AD780BR-REEL	±1.0 mV	−40°C to +85°C	3 ppm/°C	SOIC	2,500
AD780BR-REEL7	±1.0 mV	−40°C to +85°C	3 ppm/°C	SOIC	750
AD780BRZ ¹	±1.0 mV	−40°C to +85°C	3 ppm/°C	SOIC	98
AD780BRZ-REEL7 ¹	±1.0 mV	−40°C to +85°C	3 ppm/°C	SOIC	750
AD780CR	±1.5 mV	−40°C to +85°C	7 ppm/°C	SOIC	98
AD780CR-REEL7	±1.5 mV	−40°C to +85°C	7 ppm/°C	SOIC	750
AD780CRZ ¹	±1.5 mV	−40°C to +85°C	7 ppm/°C	SOIC	98

¹ Z = Pb-free part.