

# MAXIM

## CMOS 10 and 12 Bit Multiplying D/A Converters

### General Description

The AD7520 and AD7521 are low cost CMOS multiplying digital-to-analog converters (DACs) with 10 and 12 bit resolution respectively. Both DACs operate from a +5V to +15V supply and dissipate only 20mW.

Thin-film resistors provide typically 0.3% untrimmed gain error and 10ppm/°C gain temperature coefficient. All digital inputs are compatible with both CMOS and TTL logic levels.

Maxim's AD7520 and AD7521 are electrically and pin compatible with Analog Devices' AD7520 and AD7521. The AD7520 is packaged in a 16-lead DIP while the AD7521 is packaged in an 18-lead DIP. Both devices are also available in small outline (SO) packages.

### Applications

- Machine and Motion Control Systems
- Automatic Test Equipment
- μP Controlled Calibration Circuitry
- Programmable Gain Amplifiers
- Digitally Controlled Filters
- Programmable Power Supplies

### Pin Configuration

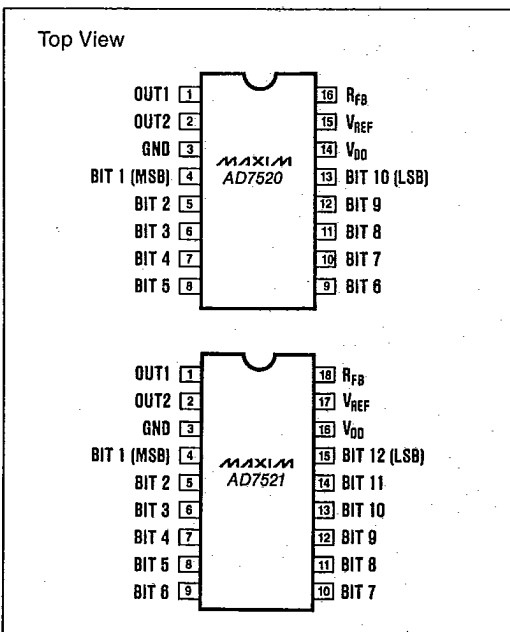

### Features

- ◆ 10 or 12 Bit Resolution *T-51-09-10*
- ◆ 8, 9, and 10 Bit End Point Linearity *T-51-09-12*
- ◆ Low Power Consumption — 20mW
- ◆ TTL and CMOS Compatible
- ◆ Pin-For-Pin Second Source

### Ordering Information

PART	TEMP RANGE	PACKAGE*	ERROR
AD7520JN	0°C to +70°C	Plastic DIP	0.2%
AD7520KN	0°C to +70°C	Plastic DIP	0.1%
AD7520LN	0°C to +70°C	Plastic DIP	0.05%
AD7520JCWE	0°C to +70°C	Small Outline	0.2%
AD7520KCWE	0°C to +70°C	Small Outline	0.1%
AD7520LCWE	0°C to +70°C	Small Outline	0.05%
AD7520JC/D	0°C to +70°C	Dice	0.2%
AD7520JQ	-25°C to +85°C	CERDIP**	0.2%
AD7520KQ	-25°C to +85°C	CERDIP**	0.1%
AD7520LQ	-25°C to +85°C	CERDIP**	0.05%
AD7520JD	-25°C to +85°C	Ceramic	0.2%
AD7520KD	-25°C to +85°C	Ceramic	0.1%
AD7520LD	-25°C to +85°C	Ceramic	0.05%
AD7520SQ	-55°C to +125°C	CERDIP**	0.2%
AD7520TQ	-55°C to +125°C	CERDIP**	0.1%
AD7520UQ	-55°C to +125°C	CERDIP**	0.05%
AD7520SD	-55°C to +125°C	Ceramic	0.2%
AD7520TD	-55°C to +125°C	Ceramic	0.1%
AD7520UD	-55°C to +125°C	Ceramic	0.05%

\* AD7520 — 16 lead package, AD7521 — 18 lead package.  
 \*\* Maxim reserves the right to ship Ceramic packages in lieu of CERDIP packages.  
 Ordering Information continued on last page.

### Typical Operating Circuit

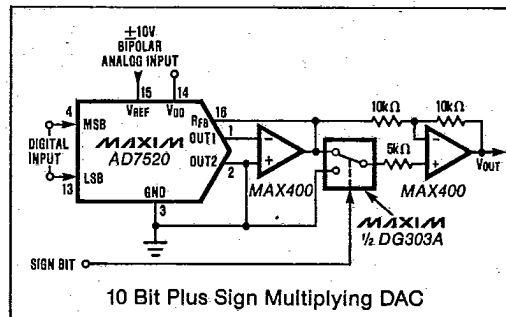

AD7520/AD7521



T-51-09-10

T-51-09-12

# CMOS 10 and 12 Bit Multiplying D/A Converters

AD7520/AD7521

## ABSOLUTE MAXIMUM RATINGS

V <sub>DD</sub> to GND	-0.3V, +17V	Operating Temperature	
V <sub>REF</sub> to GND	±25V	Commercial (JN/KN/LN/JC/KC/LC)	0°C to +70°C
R <sub>FB</sub> to GND	±25V	Industrial (JD/KD/LD/JQ/KQ/LQ)	-25°C to +85°C
Digital Input Voltage to GND	-0.3V, V <sub>DD</sub>	Military (S/T/U)	-55°C to +125°C
Output Voltage (OUT1, OUT2) (Note 1)	-0.3V, V <sub>DD</sub>	Storage Temperature	-65°C to +150°C
Power Dissipation (Derate 6mW/°C above +75°C)	450mW	Lead Temperature (Soldering 10 secs)	+300°C

Stresses above those listed under "Absolute Maximum Ratings" may cause permanent damage to the device. These are stress ratings only and functional operation of the device at these or any other conditions above those indicated in the operational sections of the specifications is not implied. Exposure to absolute maximum rating conditions for extended periods may affect device reliability.

## ELECTRICAL CHARACTERISTICS

(T<sub>A</sub> = +25°C, V<sub>DD</sub> = +15V, V<sub>REF</sub> = +10V, V<sub>OUT1</sub> = V<sub>OUT2</sub> = GND, unless otherwise specified)

PARAMETER	SYMBOL	CONDITIONS	MIN.	TYR	MAX.	UNITS
<b>DC ACCURACY (Note 2)</b>						
Resolution		AD7520 AD7521	10 12			Bits
Relative Accuracy (Note 3)		-10V ≤ V <sub>REF</sub> ≤ +10V, T <sub>A</sub> = T <sub>MIN</sub> to T <sub>MAX</sub>	0.2% FSR = 8 Bits J/S 0.1% FSR = 9 Bits K/T 0.05% FSR = 10 Bits L/U		±0.2 ±0.1 ±0.05	% FSR
Nonlinearity Tempco		-10V ≤ V <sub>REF</sub> ≤ +10V (Note 4)			2	ppm/°C
Gain Error		-10V ≤ V <sub>REF</sub> ≤ +10V (Note 5)		0.3		% FSR
Gain Error Tempco		-10V ≤ V <sub>REF</sub> ≤ +10V (Note 4,5)			10	ppm/°C
Output Leakage Current		OUT1 or OUT2, T <sub>A</sub> = T <sub>MIN</sub> to T <sub>MAX</sub>		200		nA
Power Supply Rejection	PSRR	(Note 3)		50		ppm/ %V <sub>DD</sub>
V <sub>REF</sub> Input Resistance	R <sub>REF</sub>	R <sub>REF</sub> tempco = -150ppm/°C typ.	5	10	20	kΩ
<b>AC ACCURACY</b>						
Output Current Settling Time (Note 3)		To 0.05% of FSR, all digital inputs high to low and low to high.		500		ns
Feedthrough Error (Note 3,4,6)		All digital inputs low, V <sub>REF</sub> = 20V <sub>P-P</sub> , 100kHz sinewave.		10		mV <sub>P-P</sub>
<b>ANALOG OUTPUTS</b>						
Output Capacitance (Note 3)	C <sub>OUT</sub>	All digital inputs high, OUT1 All digital inputs low, OUT2		120 37 37 120		pF
Output Noise (Note 3)	e <sub>N</sub>	Both outputs, equivalent Johnson noise resistance			10	kΩ
<b>DIGITAL INPUTS (T<sub>A</sub> = T<sub>MIN</sub> to T<sub>MAX</sub>)</b>						
Low State Threshold	V <sub>INL</sub>				0.8	V
High State Threshold	V <sub>INH</sub>			2.4		V
Input Current		Low to high state		±1		μA
Input Coding		Unipolar (Table 1), Bipolar (Table 2)				Binary, Offset Binary
<b>POWER REQUIREMENTS</b>						
Power Supply Range	V <sub>DD</sub>		+5		+15	V
Power Supply Current	I <sub>DD</sub>	Digital inputs at GND Digital inputs high or low		5	2	nA mA
Total Power Dissipation		Including V <sub>REF</sub>			20	mW

- Note 1: V<sub>OUT1,2</sub> may exceed the Absolute Maximum voltage if the current is limited to 30mA or less.
- Note 2: Full Scale Range is 10V for unipolar mode and ±10V for bipolar mode.
- Note 3: See Test Circuits.
- Note 4: Guaranteed by design but not 100% tested.
- Note 5: Using internal feedback resistor, R<sub>FB</sub>.
- Note 6: To minimize feedthrough with the ceramic package, the metal lid must be grounded. If the lid is not grounded, then the feedthrough is 10mV typical and 30mV maximum.



T-51-09-10

T-51-09-12

# CMOS 10 and 12 Bit Multiplying D/A Converters

## Typical Operating Characteristics

AD7520/AD7521

**OUTPUT CURRENT SETTLING TIME vs. DIGITAL INPUT VOLTAGE**

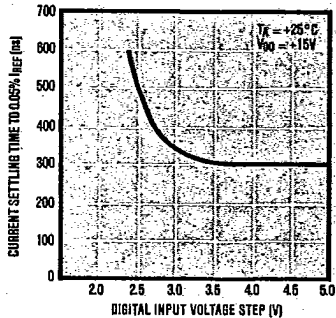

**SUPPLY CURRENT vs. TEMPERATURE**

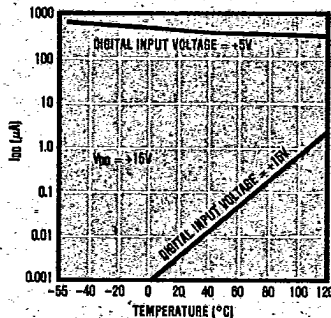

**SUPPLY CURRENT vs. SUPPLY VOLTAGE**

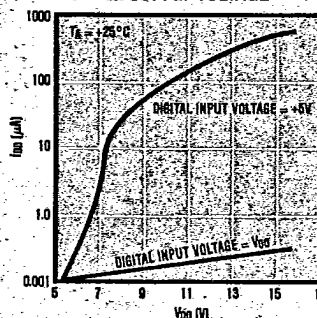

### Detailed Description

The basic AD7520/21 DAC circuit consists of a laser-trimmed, thin-film R-2R resistor array with CMOS current switches as shown in Figure 1. Binary weighted currents are switched to either OUT1 or OUT2 depending on the status of each input bit. The  $V_{REF}$  input accepts a wide range of reference signals including fixed and time-varying voltage or current inputs.

A compensation capacitor, C1, may be needed when the DAC is used with a high speed amplifier. The purpose of the capacitor is to cancel the pole formed by the DAC's output capacitance and internal feedback resistance. The correct compensation value depends on the type of op-amp used but typically ranges from 10 to 50pF.

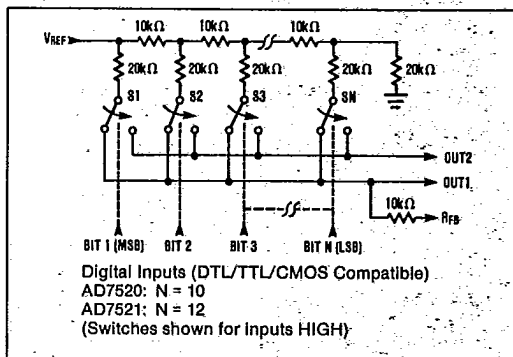

Figure 1. AD7520/AD7521 Functional Diagram

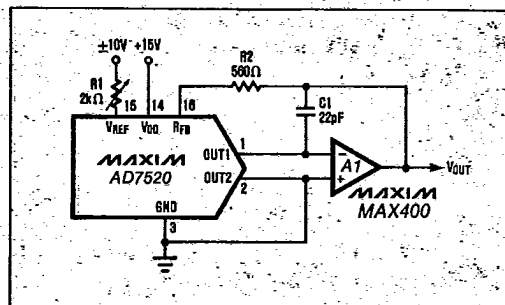

Figure 2. Unipolar Binary Operation (2-Quadrant Multiplication)

**Table 1: Code Table (AD7520) — Unipolar Binary Operation**

DIGITAL INPUT	ANALOG OUTPUT
1 1 1 1 1 1 1 1 1 1	$-V_{REF} (1 - 2^{-10})$
1 0 0 0 0 0 0 0 0 1	$-V_{REF} (\frac{1}{2} + 2^{-10})$
1 0 0 0 0 0 0 0 0 0	$-V_{REF}/2$
0 1 1 1 1 1 1 1 1 1	$-V_{REF} (\frac{1}{2} - 2^{-10})$
0 0 0 0 0 0 0 0 0 1	$-V_{REF} (2^{-10})$
0 0 0 0 0 0 0 0 0 0	0

Note: 1 LSB =  $2^{-10} V_{REF}$  (AD7520)

### Application Information

#### Unipolar Operation

The most common configuration for the AD7520/21 is shown in Figure 2. The circuit is used for unipolar binary operation and/or 2-quadrant multiplication. R1 is used for gain adjustment. If no adjustment is desired, R1 and R2 can be omitted. The code table for unipolar operation is given in Table 1. Note that the output polarity is the inverse of the reference input.

2

T-51-09-10

T-51-09-12

# CMOS 10 and 12 Bit Multiplying D/A Converters

AD7520/AD7521

The output op-amp's offset voltage can degrade DAC linearity by causing OUT1 to be terminated at a non-zero voltage. The resulting linearity error is typically  $2/3V_{OS}$ . For best performance, a low-offset amplifier such as the MAX400 should be used, or the amplifier offset must be trimmed to typically no more than 1/10 of an LSB's value. The op-amp's input bias current ( $I_B$ ) can also limit performance since  $I_B \times R_{FB}$  generates an offset error as well.  $I_B$  should therefore be much less than the DAC's output current for 1 LSB, which is typically  $1\mu A$  for the AD7520 and  $250nA$  for the AD7521.

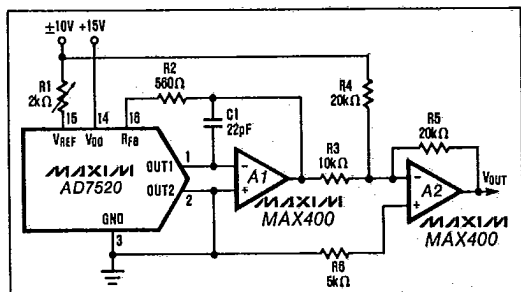

Figure 3. Bipolar Operation (4-Quadrant Multiplication)

Table 2: Code Table (AD7520) — Bipolar (Offset Binary) Operation

DIGITAL INPUT	ANALOG OUTPUT
1 1 1 1 1 1 1 1 1 1	$-V_{REF} (1 - 2^{-9})$
1 0 0 0 0 0 0 0 0 1	$-V_{REF} (2^{-9})$
1 0 0 0 0 0 0 0 0 0	0
0 1 1 1 1 1 1 1 1 1	$V_{REF} (2^{-9})$
0 0 0 0 0 0 0 0 0 1	$V_{REF} (1 - 2^{-9})$
0 0 0 0 0 0 0 0 0 0	$V_{REF}$

Note: 1 LSB =  $2^{-9} V_{REF}$  (AD7520)

### Bipolar Operation

Bipolar, or four-quadrant, operation is shown in Figure 3. A second amplifier and three matched resistors are required. The output vs. code table is listed in Table 2. In multiplying applications, the MSB determines polarity while the remaining bits control amplitude.

To adjust the circuit, load the DAC with a code of 1000 0000 0000 and trim R1 for a 0V output. With R1 and R2 omitted, an alternative zero trim is to adjust the ratio of R3 and R4 for 0V out. Full scale can be trimmed by loading the DAC with all "zeros" or all "ones" and adjusting the amplitude of  $V_{REF}$  or varying R5 until the desired positive or negative output is obtained. The op-amp recommendations made in the Unipolar Operation section apply for bipolar operation as well.

### Voltage Mode (Single Supply)

The AD7520 is connected as a voltage output DAC in Figure 4. OUT1 is connected to the external reference and OUT2 is grounded.  $V_{REF}$ , now the DAC output, is a voltage source with a constant output resistance of  $R_{ladder}$  (nominally  $10k\Omega$ ). In most circuits this output is buffered with an op-amp.

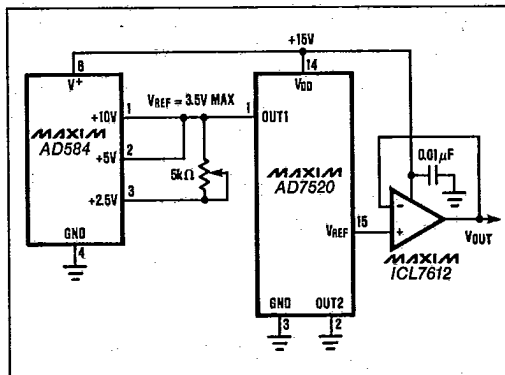

Figure 4. Single Supply Voltage Mode Operation

An advantage of voltage mode operation is single supply operation for the complete circuit, i.e. a negative reference is not required for a positive output. It is important to note that the range of the reference is restricted. The reference input (voltage at OUT1) must always be positive and is limited to no more than 3.5V when  $V_{DD}$  is 15V. If the reference voltage is greater than 3.5V, or  $V_{DD}$  is reduced, linearity is degraded.

### Dynamic Considerations

In static or DC applications, the AC characteristics of the output amplifier are not critical. In higher speed applications, where either the reference input is an AC signal or the DAC output must quickly settle to a new programmed value, the AC parameters of the output op-amp must be considered.

Another error source in dynamic applications is parasitic coupling of signal from the  $V_{REF}$  terminal to OUT1 or OUT2. This is normally a function of board layout and package lead-to-lead capacitance. Signals can also be injected into the DAC outputs when the digital inputs are switched. This digital feedthrough is mostly dependent on circuit board layout and on-chip capacitive coupling. Layout Induced feedthrough can be minimized with guard traces between digital inputs,  $V_{REF}$ , and the DAC outputs.

T-51-09-10

T-51-09-12

# CMOS 10 and 12 Bit Multiplying D/A Converters

Test Circuits

AD7520/AD7521

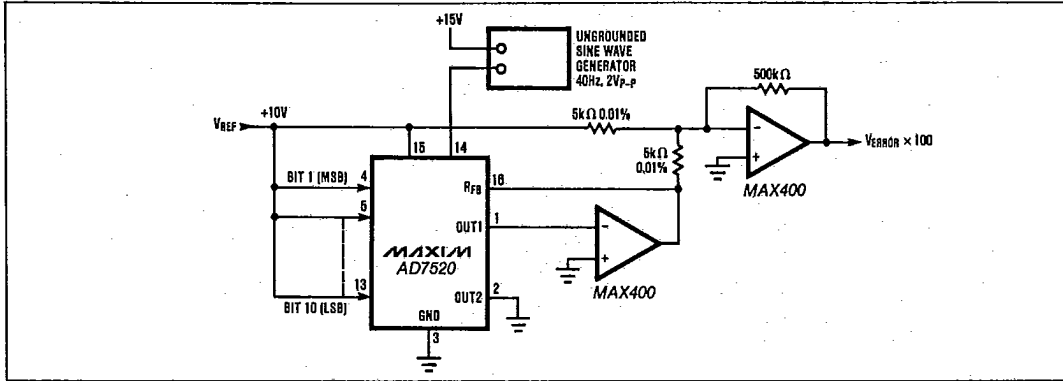

Figure 5. Power Supply Rejection

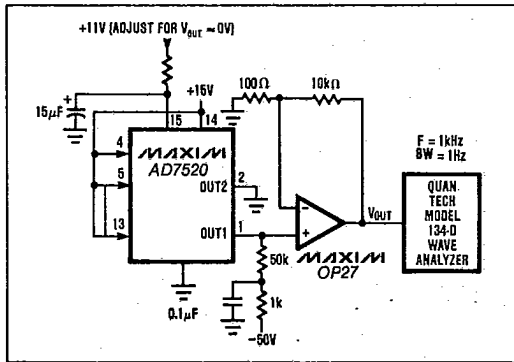

Figure 6. Noise

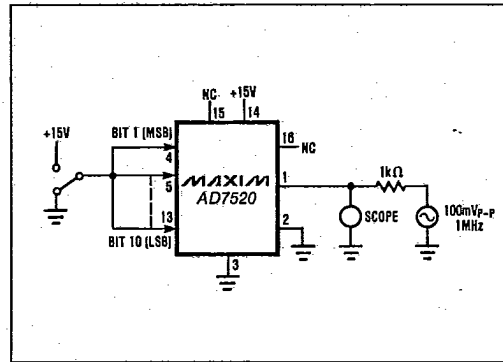

Figure 7. Output Capacitance

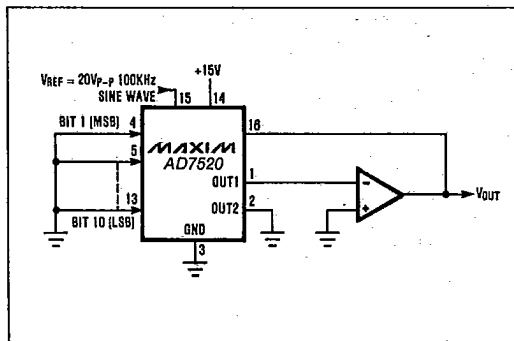

Figure 8. Feedthrough Error

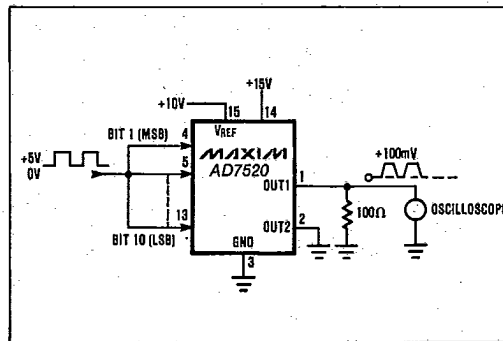

Figure 9. Output Current Settling Time

2

T-51-09-10

T-51-09-12

# CMOS 10 and 12 Bit Multiplying D/A Converters

AD7520/AD7521

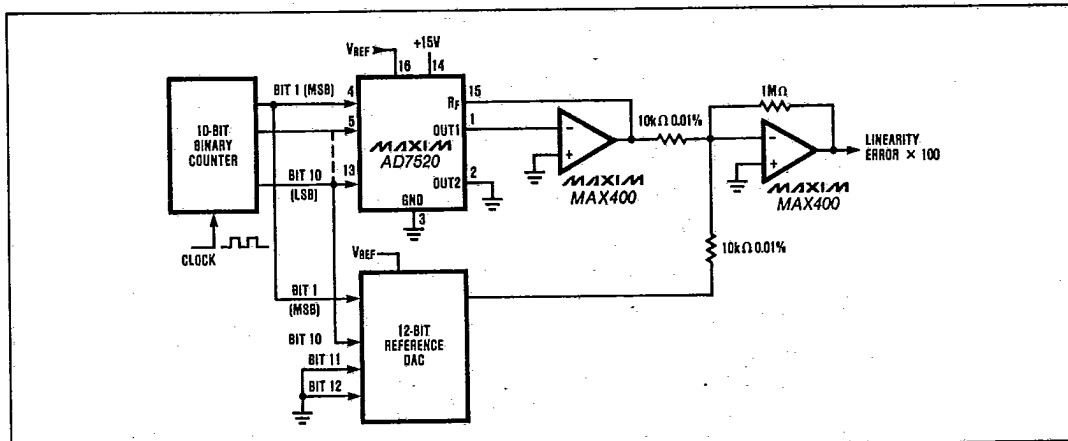

Figure 10. Relative Accuracy

### Ordering Information (continued)

PART	TEMP RANGE	PACKAGE*	ERROR
AD7521JN	0°C to +70°C	Plastic DIP	0.2%
AD7521KN	0°C to +70°C	Plastic DIP	0.1%
AD7521LN	0°C to +70°C	Plastic DIP	0.05%
AD7521JCWN	0°C to +70°C	Small Outline	0.2%
AD7521KCWN	0°C to +70°C	Small Outline	0.1%
AD7521LCWN	0°C to +70°C	Small Outline	0.05%
AD7521JC/D	0°C to +70°C	Dice	0.2%
AD7521JQ	-25°C to +85°C	CERDIP**	0.2%
AD7521KQ	-25°C to +85°C	CERDIP**	0.1%
AD7521LQ	-25°C to +85°C	CERDIP**	0.05%
AD7521JD	-25°C to +85°C	Ceramic	0.2%
AD7521KD	-25°C to +85°C	Ceramic	0.1%
AD7521LD	-25°C to +85°C	Ceramic	0.05%
AD7521SQ	-55°C to +125°C	CERDIP**	0.2%
AD7521TQ	-55°C to +125°C	CERDIP**	0.1%
AD7521UQ	-55°C to +125°C	CERDIP**	0.05%
AD7521SD	-55°C to +125°C	Ceramic	0.2%
AD7521TD	-55°C to +125°C	Ceramic	0.1%
AD7521UD	-55°C to +125°C	Ceramic	0.05%

\* AD7520 — 16 lead package, AD7521 — 18 lead package.  
 \*\* Maxim reserves the right to ship Ceramic packages in lieu of CERDIP packages.

### Chip Topography

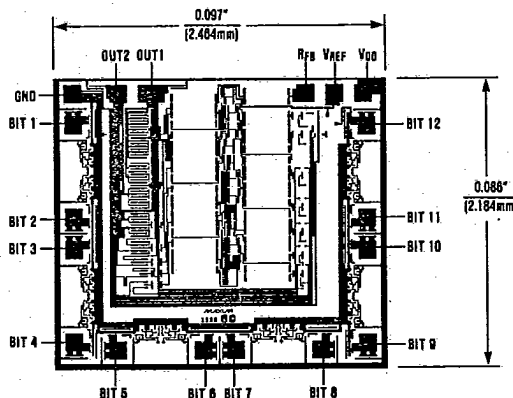

Maxim cannot assume responsibility for use of any circuitry other than circuitry entirely embodied in a Maxim product. No circuit patent licenses are implied. Maxim reserves the right to change the circuitry and specifications without notice at any time.