

THIS COPY IS PROVIDED ON A RESTRICTED BASIS AND IS NOT TO BE USED IN ANY WAY DETRIMENTAL TO THE INTERESTS OF PANDUIT CORP.

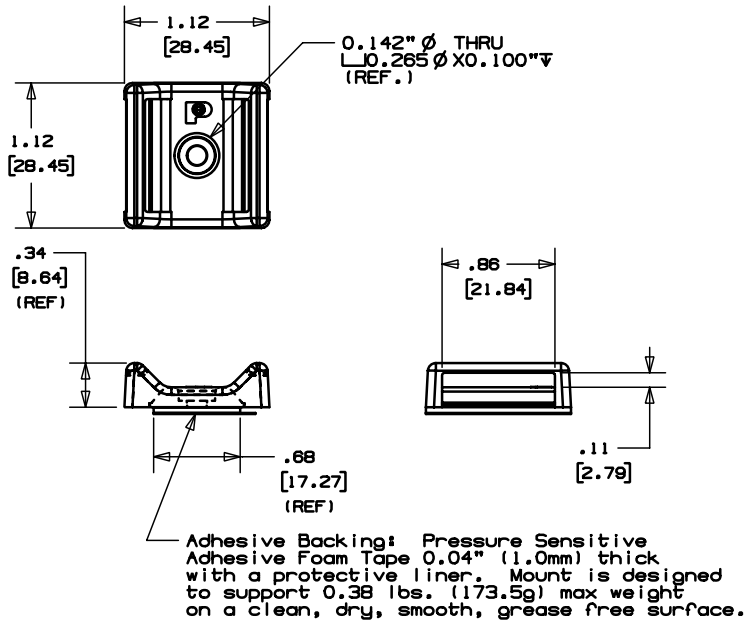

PANDUIT PART NO. (*)	WEIGHT lbs / 100 (g) / pcs.
ABMT-___-___	NO ADHESIVE 0.64 (291.4)
	WITH ADHESIVE 0.65 (294.8)

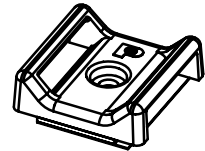
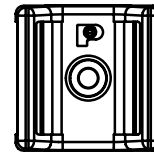

SCALE: FULL

**NOTES:**

- SEE CURRENT PRICE SHEET FOR PART NUMBER SUFFIX DESIGNATION FOR PACKAGE SIZE AND COLOR.
- A SUFFIX REPRESENTS RUBBER ADHESIVE  
-AT SUFFIX REPRESENTS ACRYLIC ADHESIVE  
-S6 SUFFIX, NO ADHESIVE; SCREW APPLIED WITH A #6-32 BUTTON HEAD CAP SCREW.
- ABMT-A HAS A MAXIMUM CONTINUOUS OPERATING TEMPERATURE OF 120°F (49°C).  
ABMT-AT HAS A MAXIMUM CONTINUOUS OPERATING TEMPERATURE OF 180°F (82°C).

DIMENSIONS IN BRACKETS ARE METRIC [ mm ]	
CND FILENAME/LAYER# G02471CB_PB_ABMT_01	
<b>PANDUIT</b> CORP. TINLEY PARK, ILLINOIS	
ADHESIVE BACKED "TAK-TY" MOUNT (ABMT-___-___)	
UNLESS OTHERWISE SPECIFIED, DIMENSIONAL TOLERANCES ARE: (.X) ±0.05 (1.3) (.XXX) ±0.010 (0.25) (.XX) ±0.02 (0.5) ANGLES ±5°	UNLESS OTHERWISE SPECIFIED, ALL DIMENSIONS ARE GIVEN IN INCHES, THIRD ANGLE PROJECTION.
DRAWN BY JAD	MAT'L: NYLON 6/6
DATE 1/28/02	SCALE NONE
DWG NO. GB2471CB	DWG SIZE A

REV	DATE	BY	CHK	DESCRIPTION	ECN	R	CUST	SUP
1	2/11/05	JAD		1.12 was 1.10	002471CB	1		