

HC/49US (AT49) LOW PROFILE SURFACE MOUNT MICROPROCESSOR CRYSTAL

ABLS3



RoHS Compliant



11.5 x 4.8 x 2.5 mm

FEATURES:

- Suitable for reflow
- Low height reduced to 2.5mm
- Suitable for thin equipment
- Tight stability & extended temperature

APPLICATIONS:

- Computers, Modems, Microprocessors
- Automotive and Industrial
- Wireless Applications

PARAMETERS

ABRACON P/N	ABLS3 Series
Frequency	3.579545 MHz to 70 MHz
Operation Mode	AT cut (Fundamental or 3rd OT) or BT cut (See options) 3.579545MHz - 24.0MHz (Fundamental) (Standard) 24.01 - 70.00MHz (3rd- Overtone) (Standard) 24.01MHz - 50.00MHz (Fund. AT or BT) (See options)
Operating Temperature	0°C to +70°C (see options)
Storage Temperature	-55°C to +125°C
Frequency Tolerance at +25°C	± 50 ppm max. (see options)
Frequency Stability over the Operating Temp. (Ref to +25°C)	± 50 ppm max. (see options)
Equivalent Series Resistance	See Table 1
Shunt Capacitance C ₀	7pF max.
Load Capacitance C _L	18pF (see options)
Drive Level	1 mW max., 100µW correlation
Aging at 25°C ± 3°C Per Year	± 5ppm max.
Insulation Resistance	500 MΩ min at 100Vdc ± 15V
Drive level dependency (DLD)	from 1µW to 500µW (minimum 7 points tested)

TABLE 1: ESR

FREQUENCY (MHz)	ESR (Ω)
3.579 - 4.999 (Fund.)	180
5.000 - 5.999 (Fund.)	120
6.000 - 7.999 (Fund.)	100
8.000 - 8.999 (Fund.)	80
9.000 - 9.999 (Fund.)	60
10.000 - 15.999 (Fund.)	50
16.000 - 50.000 (Fund.)	40
24.01 - 31.999 (3rd O/T)	100
32.000 - 70.00 (3rd O/T)	80

- Change in frequency (Maximum - Minimum) over DLD range < ±10ppm
- Change in ESR (Maximum - Minimum) over DLD range < 25% of Max ESR value
- Maximum ESR over DLD range < Max ESR value

OPTIONS & PART IDENTIFICATION:

(Left blank if standard)

ABLS3 - Frequency - - R - - - - - -

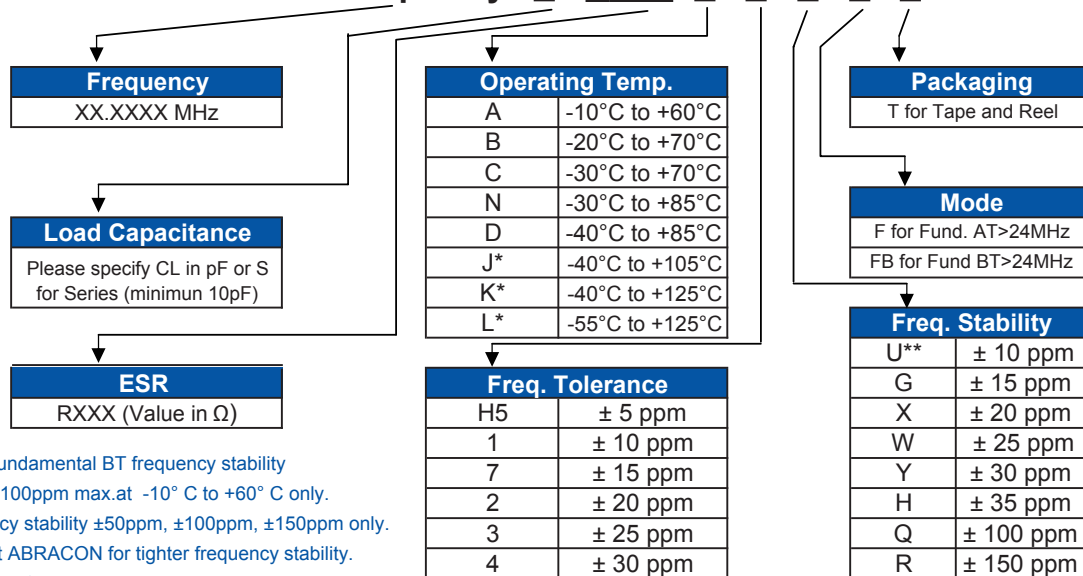

NOTE: Fundamental BT frequency stability ± 100ppm max.at -10° C to +60° C only.

* Frequency stability ±50ppm, ±100ppm, ±150ppm only. Contact ABRACON for tighter frequency stability.

** -10 to +60C only.

ABRACON IS ISO 9001 / QS 9000 CERTIFIED

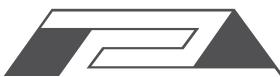

ABRACON CORPORATION

Visit www.abracon.com for Terms & Conditions of Sale **Revised: 08.20.10**

30332 Esperanza, Rancho Santa Margarita, California 92688

tel 949-546-8000 | fax 949-546-8001 | www.abracon.com

HC/49US (AT49) LOW PROFILE SURFACE MOUNT MICROPROCESSOR CRYSTAL

ABLS3



RoHS
Compliant

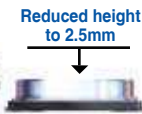

11.5 x 4.8 x 2.5 mm

OUTLINE DRAWING:

TAPE & REEL: T= tape and reel (1,000pcs/reel)

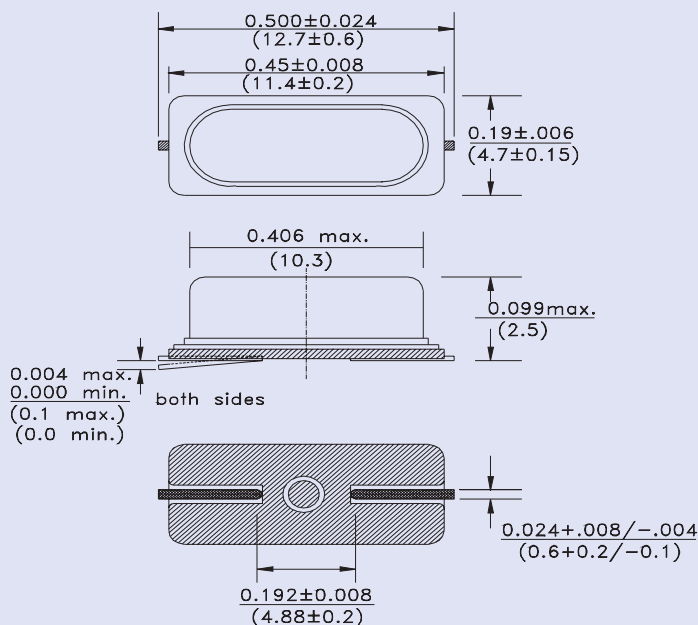

Recommended land pattern

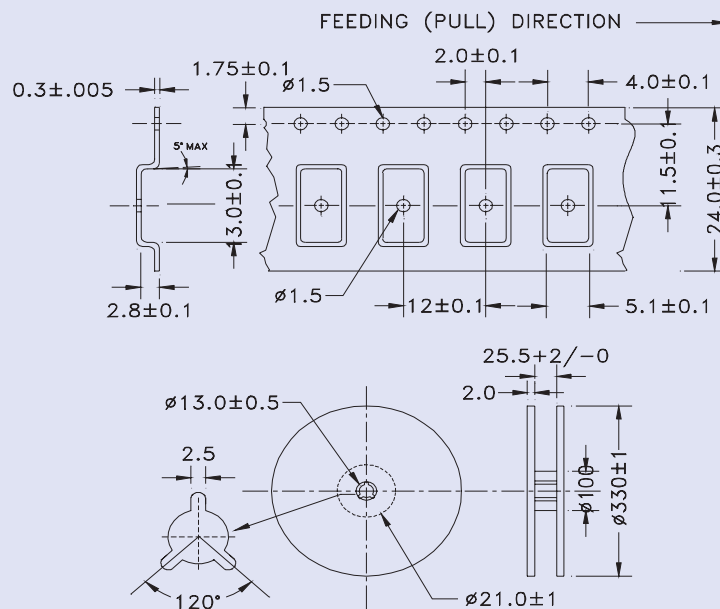
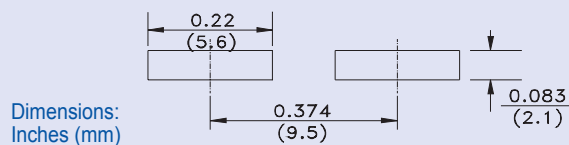

Dimensions: mm

REFLOW PROFILE:

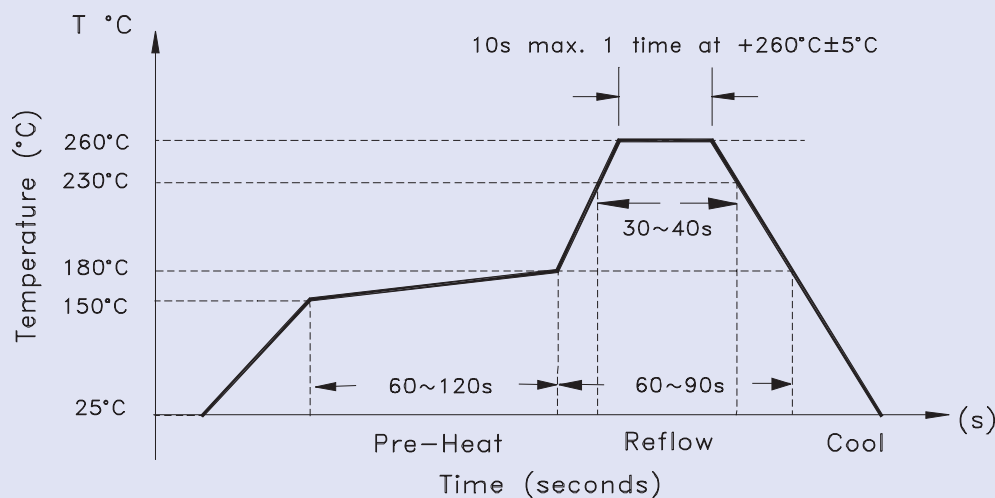

ATTENTION: Abracon Corporation's products are COTS - Commercial-Off-The-Shelf products; suitable for Commercial, Industrial and, where designated, Automotive Applications. Abracon's products are not specifically designed for Military, Aviation, Aerospace, Life-dependant Medical applications or any application requiring high reliability where component failure could result in loss of life and/or property. For applications requiring high reliability and/or presenting an extreme operating environment, written consent and authorization from Abracon Corporation is required. Please contact Abracon Corporation for more information.

ABRACON IS
ISO 9001 / QS 9000
CERTIFIED

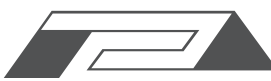

ABRACON
CORPORATION

Visit www.abracon.com for Terms & Conditions of Sale **Revised: 08.20.10**

30332 Esperanza, Rancho Santa Margarita, California 92688

tel 949-546-8000 | fax 949-546-8001 | www.abracon.com