

## Dual Full-Bridge PWM Motor Driver

### Features and Benefits

- $\pm 650$  mA continuous output current
- 30 V output voltage rating
- Internal fixed-frequency PWM current control
- Satlington® sink drivers
- User-selectable blanking window
- Internal ground-clamp and flyback diodes
- Internal thermal-shutdown circuitry
- Crossover-current protection and UVLO protection

### Package: 16 pin SOICW (suffix LB)

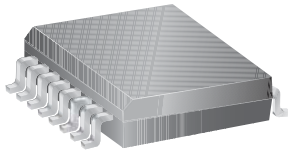

### Description

The A3966 is designed to drive both windings of a two-phase bipolar stepper motor. The device includes two full-bridges capable of continuous output currents of  $\pm 650$  mA and operating voltages to 30 V. Motor winding current can be controlled by the internal fixed-frequency, pulse-width modulated (PWM), current-control circuitry. The peak load current limit is set by user selection of a reference voltage and current-sensing resistors.

The fixed-frequency pulse duration is set by a user-selected external RC timing network. The capacitor in the RC timing network also determines a user-selectable blanking window that prevents false triggering of the PWM current-control circuitry during switching transitions.

To reduce on-chip power dissipation, the full-bridge power outputs have been optimized for low saturation voltages. The sink drivers feature the Allegro® patented Satlington® output structure. The Satlington outputs combine the low voltage drop of a saturated transistor and the high peak current capability of a Darlington.

For each bridge, a PHASE input controls load-current polarity by selecting the appropriate source and sink driver pair. For

Not to scale

Continued on the next page...

### Typical Application

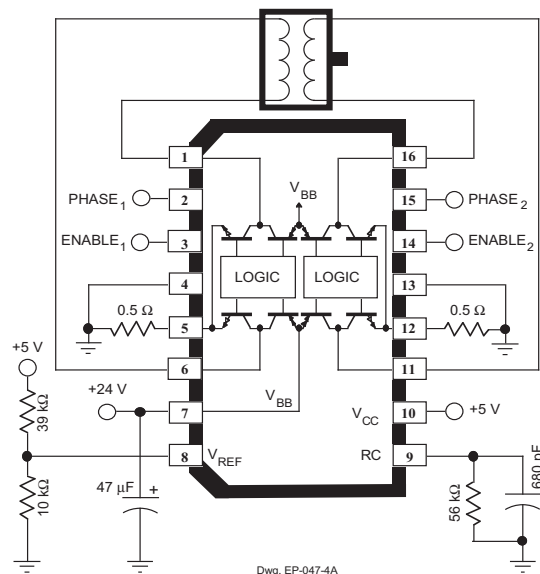

# A3966

# Dual Full-Bridge PWM Motor Driver

## Description (continued)

each bridge, an ENABLE input, when held high, disables the output drivers. Special power-up sequencing is not required. Internal circuit protection includes thermal shutdown with hysteresis, ground-clamp and flyback diodes, and crossover-current protection.

The A3966 is supplied in a 16-lead plastic wide SOIC with two pins internally fused to the die pad for enhanced thermal dissipation. These pins are at ground potential and need no electrical isolation. The device is lead (Pb) free, with 100% matte tin leadframe plating.

## Selection Guide

Part Number	Packing	Ambient Temperature Range (°C)
A3966ELBTR-T*	1000 pieces / reel	-40 to 85
A3966SLBTR-T	1000 pieces / reel	-20 to 85

\*Variant is in production but has been determined to be LAST TIME BUY. This classification indicates that the variant is obsolete and notice has been given. Sale of the variant is currently restricted to existing customer applications. The variant should not be purchased for new design applications because of obsolescence in the near future. Samples are no longer available. Status date change November 1, 2008. Deadline for receipt of LAST TIME BUY orders is May 1, 2009.

## Absolute Maximum Ratings

Characteristic	Symbol	Notes	Rating	Units	
Load Supply Voltage	$V_{BB}$		30	V	
Logic Supply Voltage	$V_{CC}$		7.0	V	
Input Voltage	$V_{IN}$		$-0.3$ to $V_{CC} + 0.3$	V	
Sense Voltage	$V_S$		1.0	V	
Output Current*	$I_{OUT}$	Peak	Output current rating may be limited by duty cycle, ambient temperature, and heat sinking. Under any set of conditions, do not exceed the specified current rating or $T_J(max)$	$\pm 750$	mA
		Continuous		$\pm 650$	mA
Package Power Dissipation	$P_D$	$T_A = 25^\circ C$ ; per SEMI G42-88 Specification, Thermal Test Board Standardization for Measuring Junction-to-Ambient Thermal Resistance of Semiconductor Packages.	1.87	W	
Operating Ambient Temperature	$T_A$	Range E	-40 to 85	°C	
		Range S	-20 to 85	°C	
Maximum Junction Temperature	$T_J(max)$		150	°C	
Storage Temperature	$T_{stg}$		-55 to 150	°C	

## Pin-out Diagram

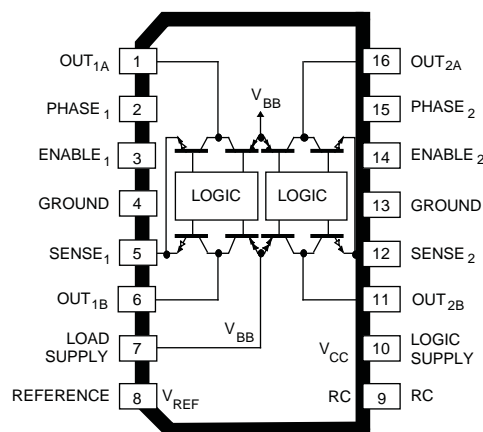

FUNCTIONAL BLOCK DIAGRAM

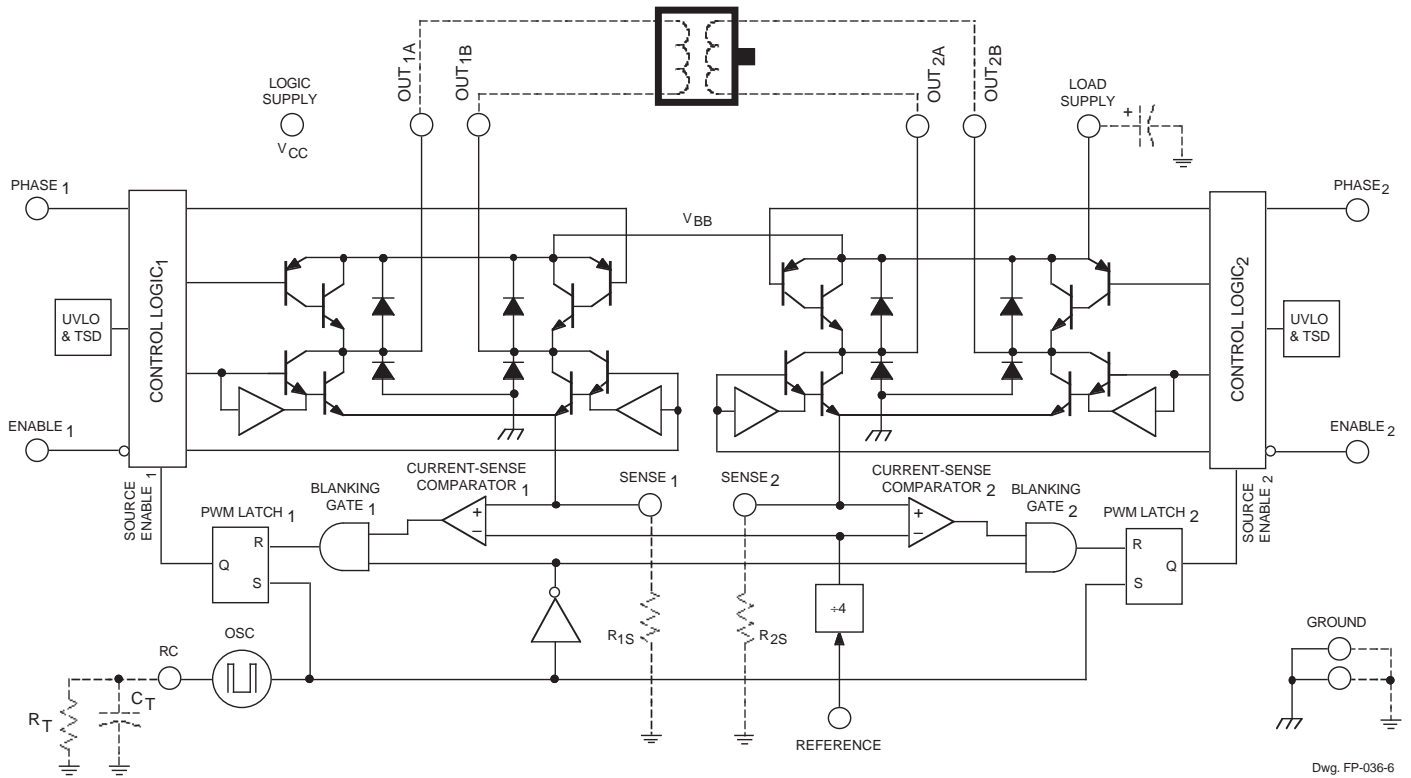

Dwg. FP-036-6

TRUTH TABLE

PHASE	ENABLE	OUT <sub>A</sub>	OUT <sub>B</sub>
X	H	Off	Off
H	L	H	L
L	L	L	H

X = Irrelevant

Typical output saturation voltages showing Satlington sink-driver operation.

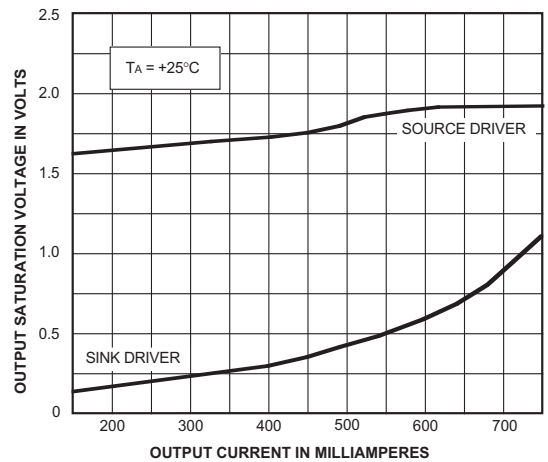

Dwg. GP-064-1A

**ELECTRICAL CHARACTERISTICS** at  $T_A = +25^\circ\text{C}$ ,  $V_{BB} = 30\text{ V}$ ,  $V_{CC} = 4.75\text{ V to } 5.5\text{ V}$ ,  $V_{REF} = 2\text{ V}$ ,  $V_S = 0\text{ V}$ ,  $56\text{ k}\Omega$  &  $680\text{ pF}$  RC to Ground (unless noted otherwise)

Characteristic	Symbol	Test Conditions	Limits			
			Min.	Typ.	Max.	Units

### Output Drivers

Load Supply Voltage Range	$V_{BB}$	Operating, $I_{OUT} = \pm 650\text{ mA}$ , $L = 3\text{ mH}$	$V_{CC}$	—	30	V
Output Leakage Current	$I_{CEX}$	$V_{OUT} = 30\text{ V}$	—	<1.0	50	$\mu\text{A}$
		$V_{OUT} = 0\text{ V}$	—	<-1.0	-50	$\mu\text{A}$
Output Saturation Voltage	$V_{CE(SAT)}$	Source Driver, $I_{OUT} = -400\text{ mA}$	—	1.7	2.0	V
		Source Driver, $I_{OUT} = -650\text{ mA}$	—	1.8	2.1	V
		Sink Driver, $I_{OUT} = +400\text{ mA}$ , $V_S = 0.5\text{ V}$	—	0.3	0.5	V
		Sink Driver, $I_{OUT} = +650\text{ mA}$ , $V_S = 0.5\text{ V}$	—	0.7	1.3	V
Clamp Diode Forward Voltage	$V_F$	$I_F = 400\text{ mA}$	—	1.1	1.4	V
		$I_F = 650\text{ mA}$	—	1.4	1.6	V
Motor Supply Current (No Load)	$I_{BB(ON)}$	$V_{ENABLE1} = V_{ENABLE2} = 0.8\text{ V}$	—	3.0	5.0	mA
	$I_{BB(OFF)}$	$V_{ENABLE1} = V_{ENABLE2} = 2.4\text{ V}$	—	<1.0	200	$\mu\text{A}$

### Control Logic

Logic Supply Voltage Range	$V_{CC}$	Operating	4.75	—	5.50	V
Logic Input Voltage	$V_{IN(1)}$		2.4	—	—	V
	$V_{IN(0)}$		—	—	0.8	V
Logic Input Current	$I_{IN(1)}$	$V_{IN} = 2.4\text{ V}$	—	<1.0	20	$\mu\text{A}$
	$I_{IN(0)}$	$V_{IN} = 0.8\text{ V}$	—	<-20	-200	$\mu\text{A}$
Reference Input Volt. Range	$V_{REF}$	Operating	0.1	—	2.0	V
Reference Input Current	$I_{REF}$		-2.5	0	1.0	$\mu\text{A}$
Reference Divider Ratio	$V_{REF}/V_{TRIP}$		3.8	4.0	4.2	—
Current-Sense Comparator Input Offset Voltage	$V_{IO}$	$V_{REF} = 0\text{ V}$	-6.0	0	6.0	mV
Current-Sense Comparator Input Voltage Range	$V_S$	Operating	-0.3	—	1.0	V
Sense-Current Offset	$I_{SO}$	$I_S - I_{OUT}$ , $50\text{ mA} \leq I_{OUT} \leq 650\text{ mA}$	12	18	24	mA

NOTES: 1. Typical Data is for design information only.

2. Negative current is defined as coming out of (sourcing) the specified device terminal.

**ELECTRICAL CHARACTERISTICS** at  $T_A = +25^\circ\text{C}$ ,  $V_{BB} = 30\text{ V}$ ,  $V_{CC} = 4.75\text{ V to }5.5\text{ V}$ ,  $V_{REF} = 2\text{ V}$ ,  $V_S = 0\text{ V}$ ,  $56\text{ k}\Omega$  &  $680\text{ pF}$  RC to Ground (unless noted otherwise) (cont.)

Characteristic	Symbol	Test Conditions	Limits			
			Min.	Typ.	Max.	Units
<b>Control Logic</b> (continued)						
PWM RC Frequency	$f_{osc}$	$C_T = 680\text{ pF}$ , $R_T = 56\text{ k}\Omega$	22.9	25.4	27.9	kHz
PWM Propagation Delay Time	$t_{PWM}$	Comparator Trip to Source OFF	—	1.0	1.4	$\mu\text{s}$
		Cycle Reset to Source ON	—	0.8	1.2	$\mu\text{s}$
Cross-Over Dead Time	$t_{codt}$	1 k $\Omega$ Load to 25 V	0.2	1.8	3.0	$\mu\text{s}$
Propagation Delay Times	$t_{pd}$	$I_{OUT} = \pm 650\text{ mA}$ , 50% to 90%: ENABLE ON to Source ON	—	100	—	ns
		ENABLE OFF to Source OFF	—	500	—	ns
		ENABLE ON to Sink ON	—	200	—	ns
		ENABLE OFF to Sink OFF	—	200	—	ns
		PHASE Change to Sink ON	—	2200	—	ns
		PHASE Change to Sink OFF	—	200	—	ns
		PHASE Change to Source ON	—	2200	—	ns
		PHASE Change to Source OFF	—	200	—	ns
Thermal Shutdown Temp.	$T_J$		—	165	—	$^\circ\text{C}$
Thermal Shutdown Hysteresis	$\Delta T_J$		—	15	—	$^\circ\text{C}$
UVLO Enable Threshold	$V_{T(UVLO)+}$	Increasing $V_{CC}$	—	4.1	4.6	V
UVLO Hysteresis	$V_{T(UVLO)hys}$		0.1	0.6	—	V
Logic Supply Current	$I_{CC(ON)}$	$V_{ENABLE 1} = V_{ENABLE 2} = 0.8\text{ V}$	—	—	50	mA
	$I_{CC(OFF)}$	$V_{ENABLE 1} = V_{ENABLE 2} = 2.4\text{ V}$	—	—	9.0	mA

NOTES: 1. Typical Data is for design information only.

2. Negative current is defined as coming out of (sourcing) the specified device terminal.

FUNCTIONAL DESCRIPTION

**Internal PWM Current Control.** The A3966 dual full-bridges are designed to drive both windings of a bipolar stepper motor. Load current can be controlled in each motor winding by an internal fixed-frequency PWM control circuit. The current-control circuitry works as follows: when the outputs of the full-bridge are turned on, current increases in the motor winding. The load current is sensed by the current-control comparator via an external sense resistor ( $R_S$ ). Load current continues to increase until it reaches the predetermined value, set by the selection of external current-sensing resistors and reference input voltage ( $V_{REF}$ ) according to the equation:

$$I_{TRIP} = I_{OUT} + I_{SO} = V_{REF}/(4 R_S)$$

where  $I_{SO}$  is the sense-current error (typically 18 mA) due to the base-drive current of the sink driver transistor.

At the trip point, the comparator resets the source-enable latch, turning off the source driver of that full-bridge. The source turn-off of one full-bridge is independent of the other full-bridge. Load inductance causes the current to recirculate through the sink driver and ground-clamp diode. The current decreases until the internal clock oscillator sets the source-enable latches of both Full-bridges, turning on the source drivers of both bridges. Load current increases again, and the cycle is repeated.

The frequency of the internal clock oscillator is set by the external timing components  $R_T C_T$ . The frequency can

be approximately calculated as:

$$f_{osc} = 1/(R_T C_T + t_{blank})$$

where  $t_{blank}$  is defined below.

The range of recommended values for  $R_T$  and  $C_T$  are 20 to 100 k $\Omega$  and 470 to 1000 pF respectively. Nominal values of 56 k $\Omega$  and 680 pF result in a clock frequency of 25 kHz.

**Current-Sense Comparator Blanking.** When the source driver is turned on, a current spike occurs due to the reverse-recovery currents of the clamp diodes and switching transients related to distributed capacitance in the load. To prevent this current spike from erroneously resetting the source enable latch, the current-control comparator output is blanked for a short period of time when the source driver is turned on. The blanking time is set by the timing component  $C_T$  according to the equation:

$$t_{blank} = 1900 C_T (\mu s).$$

A nominal  $C_T$  value of 680 pF will give a blanking time of 1.3  $\mu s$ .

The current-control comparator is also blanked when the Full-bridge outputs are switched by the PHASE or ENABLE inputs. This internally generated blank time is approximately 1  $\mu s$ .

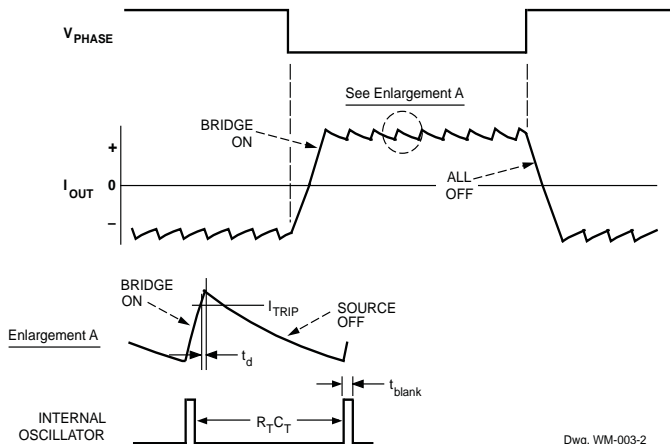

Dwg. WM-003-2

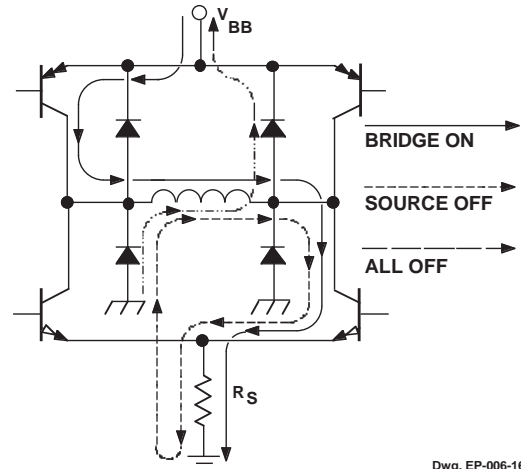

Dwg. EP-006-16

**FUNCTIONAL DESCRIPTION** (continued)

**Load Current Regulation.** Due to internal logic and switching delays,  $t_d$ , the actual load current peak will be slightly higher than the  $I_{TRIP}$  value. These delays, plus the blanking time, limit the minimum value the current control circuitry can regulate. To produce zero current in a winding, the ENABLE terminal should be held high, turning off all output drivers for that full-bridge.

**Logic Inputs.** A logic high on the PHASE input results in current flowing from  $OUT_A$  to  $OUT_B$  of that full-bridge. A logic low on the PHASE input results in current flowing from  $OUT_B$  to  $OUT_A$ . An internally generated dead time,  $t_{codt}$ , of approximately 1  $\mu s$  prevents crossover-current spikes that can occur when switching the PHASE input.

A logic high on the ENABLE input turns off all four output drivers of that full-bridge. This results in a fast current decay through the internal ground clamp and flyback diodes. A logic low on the ENABLE input turns on the selected source and sink driver of that full-bridge.

The ENABLE inputs can be pulse-width modulated for applications that require a fast current-decay PWM. If external current-sensing circuitry is used, the internal current-control logic can be disabled by connecting the  $R_T C_T$  terminal to ground.

The REFERENCE input voltage is typically set with a resistor divider from  $V_{CC}$ . This reference voltage is internally divided down by 4 to set up the current-comparator trip-voltage threshold. The reference input voltage range is 0 to 2 V.

**Output Drivers.** To minimize on-chip power dissipation, the sink drivers incorporate a Satlington structure. The Satlington output combines the low  $V_{CE(sat)}$  features of a saturated transistor and the high peak-current capability of a Darlington (connected) transistor. A graph showing typical output saturation voltages as a function of output current is on page 5.

**Miscellaneous Information.** Thermal protection circuitry turns off all output drivers should the junction temperature reach 165 °C typical. This is intended only to protect the device from failures due to excessive junction temperatures and should not imply that output short circuits are permitted. Normal operation is resumed when the junction temperature has decreased about 15°C.

The A3966 current control employs a fixed-frequency, variable duty cycle PWM technique. As a result, the current-control regulation may become unstable if the duty cycle exceeds 50%.

To minimize current-sensing inaccuracies caused by ground trace  $I_R$  drops, each current-sensing resistor should have a separate return to the ground terminal of the device. For low-value sense resistors, the  $I \times R$  drops in the printed-wiring board can be significant and should be taken into account. The use of sockets should be avoided as their contact resistance can cause variations in the effective value of  $R_S$ .

The LOAD SUPPLY terminal,  $V_{BB}$ , should be decoupled with an electrolytic capacitor (47  $\mu F$  recommended) placed as close to the device as physically practical. To minimize the effect of system ground  $I \times R$  drops on the logic and reference input signals, the system ground should have a low-resistance return to the load supply voltage.

The frequency of the clock oscillator will determine the amount of ripple current. A lower frequency will result in higher current ripple, but reduced heating in the motor and driver IC due to a corresponding decrease in hysteretic core losses and switching losses respectively. A higher frequency will reduce ripple current, but will increase switching losses and EMI.

## Package LB, 16-pin SOICW

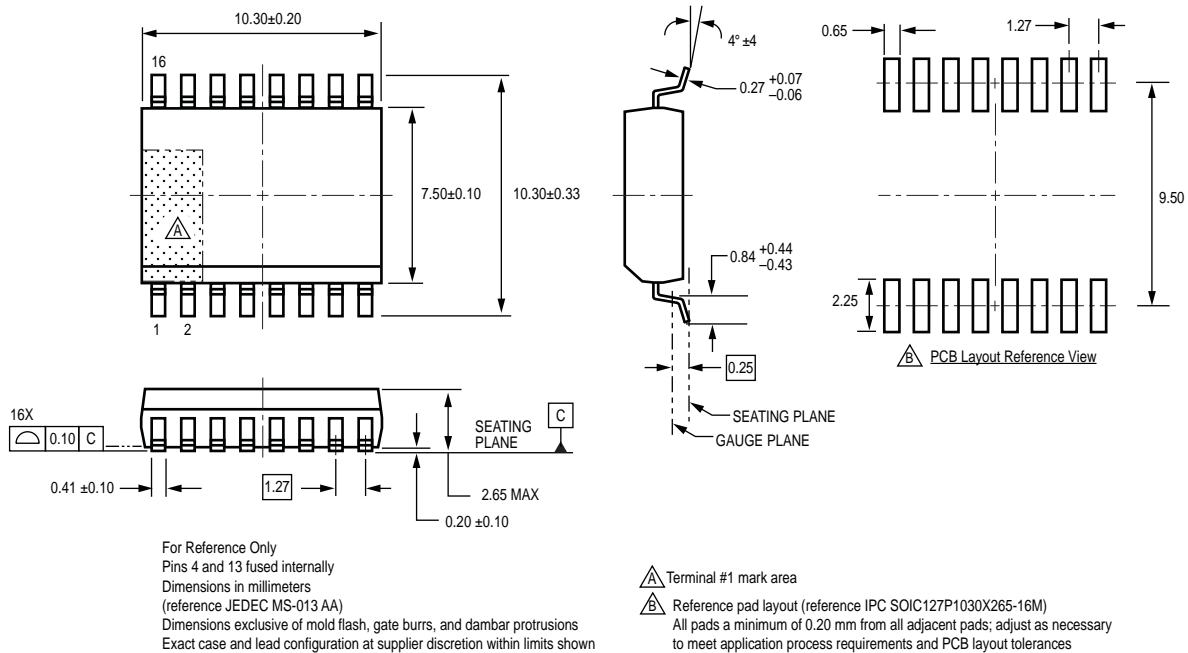

Copyright ©1998-2009, Allegro MicroSystems, Inc.

The products described here are manufactured under one or more U.S. patents or U.S. patents pending.

Satlington® is a registered trademark of Allegro MicroSystems, Inc. (Allegro), and Satlington devices are manufactured under U. S. Patent No. 5,684,427.

Allegro MicroSystems, Inc. reserves the right to make, from time to time, such departures from the detail specifications as may be required to permit improvements in the performance, reliability, or manufacturability of its products. Before placing an order, the user is cautioned to verify that the information being relied upon is current.

Allegro's products are not to be used in life support devices or systems, if a failure of an Allegro product can reasonably be expected to cause the failure of that life support device or system, or to affect the safety or effectiveness of that device or system.

The information included herein is believed to be accurate and reliable. However, Allegro MicroSystems, Inc. assumes no responsibility for its use; nor for any infringement of patents or other rights of third parties which may result from its use.

For the latest version of this document, visit our website:

[www.allegromicro.com](http://www.allegromicro.com)



Allegro MicroSystems, Inc.  
115 Northeast Cutoff  
Worcester, Massachusetts 01615-0036 U.S.A.  
1.508.853.5000; [www.allegromicro.com](http://www.allegromicro.com)