

Data Sheet

Rev. 3.0 / October 2011

A²SI-Light 14 / A²SI-Light 16

Low End Device AS-Interface IC



A²SI-Light 14 / A²SI-Light 16

Low End Device AS-Interface IC

ZMDI[®]
The Analog Mixed Signal Company



Brief Description

A²SI-Lite is a CMOS integrated circuit for AS-I (Actuator Sensor Interface) networks. The AS-I low-level field bus was designed for easy, safe and cost-effective interconnection of sensors, actuators and switches. It transports both power and data over the same two-wire unshielded cable. A²SI-Lite works in bus nodes as interfaces between the application and the physical layer (cable). The devices realize power supply, physical data transfer and communication protocol handling. It provides extended address mode, which allows the interconnection of up to 62 slave modules. The low-cost A²SI-Lite can be used in slave units. Certified to AS-I specification V3.0 the device is perfect for interconnecting simple switches and LEDs.

Features

- Slave operation only
- Certified to AS-I specification V3.0
- 2I/2O data port
- PWM output option
- 2 diagnostic pins (A²SI-L16 only)

Benefits

- Suitable for Low-End-Devices, for instance pushbuttons and pilot-lights
- Very small package SOP 14 and SOP 16

Available Support

- ZMDI AS-Interface Programmer Kit USB

Physical Characteristics

- Operational temperature range: -25 to +85°C
- SOP14 A²SI-L14 package
- SOP16 A²SI-L16 package

A²SI-Lite Basic Application Circuit

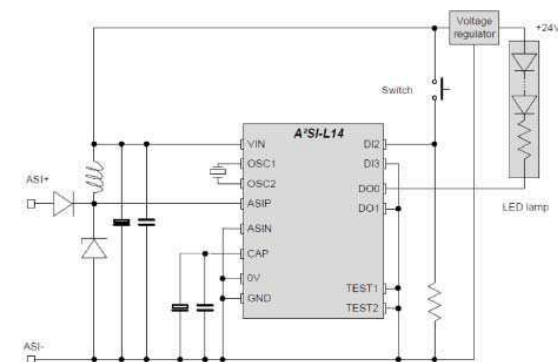

Figure 9-2: Typical application I.

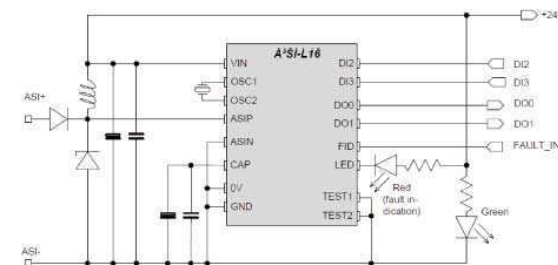

Figure 9-2: Typical application II.

A²SI-Light 14 / A²SI-Light 16

Low End Device AS-Interface IC

ZMDI[®]

The Analog Mixed Signal Company



A²SI-Light Block Diagram

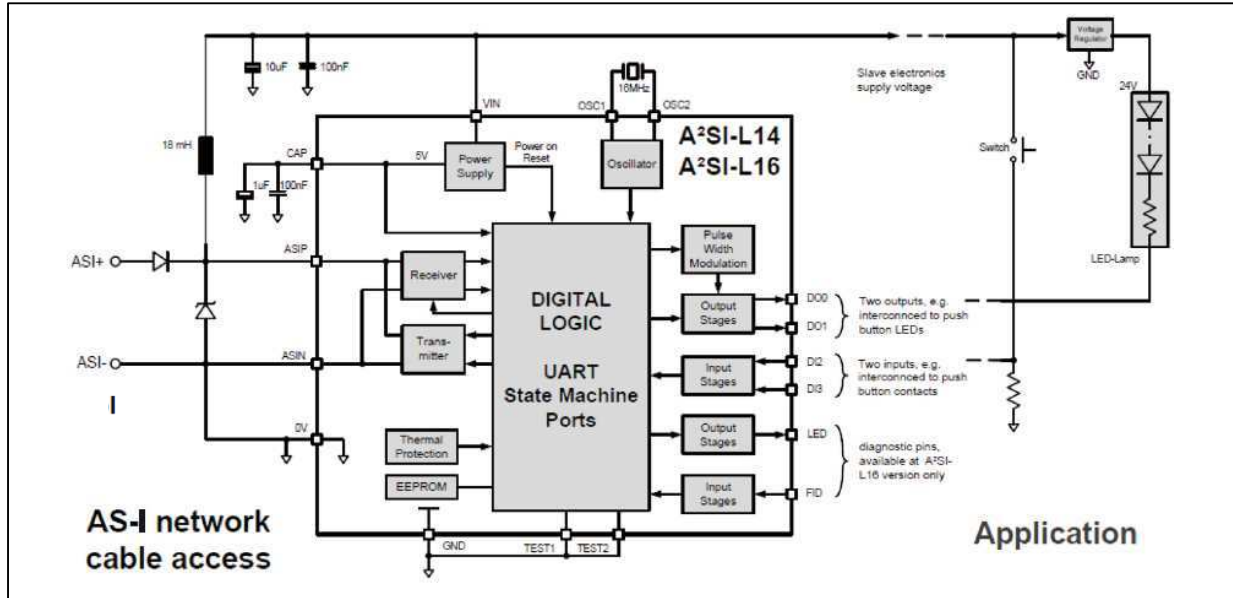

Ordering Information

Ordering Code	Product Description	Packaging
A2SI-L14-ST	A ² SI-Lite 14 pin SOP 150 mil package	Tube
A2SI-L14-SR	(without diagnostic pins)	Tape & Reel
A2SI-L16-ST	A ² SI-Lite 16 pin SOP 150 mil package	Tube
A2SI-L16-SR	(with diagnostic pins)	Tape & Reel

Sales and Further Information		www.zmdi.com	asi@zmdi.com
Zentrum Mikroelektronik Dresden AG Grenzstrasse 28 01109 Dresden Germany Phone +49 (0)351.8822.7274 Fax +49 (0)351.8822.87274	ZMD America, Inc. 8413 Excelsior Drive Suite 200 Madison, WI 53717 USA Phone +1 (608) 829-1987 Fax +1 (631) 549-2882	Zentrum Mikroelektronik Dresden AG, Japan Office 2nd Floor, Shinbashi Tokyu Bldg. 4-21-3, Shinbashi, Minato-ku Tokyo, 105-0004 Japan Phone +81.3.6895.7410 Fax +81.3.6895.7301	ZMD FAR EAST, Ltd. 3F, No. 51, Sec. 2, Keelung Road 11052 Taipei Taiwan Phone +886 2 2377 8189 Fax +886 2 2377 8199
<p>DISCLAIMER: This information applies to a product under development. Its characteristics and specifications are PRELIMINARY and subject to change without notice. Zentrum Mikroelektronik Dresden AG (ZMD AG) assumes no obligation regarding future manufacture unless otherwise agreed to in writing. The information furnished hereby is believed to be true and accurate. However, under no circumstances shall ZMD AG be liable to any customer, licensee, or any other third party for any special, indirect, incidental, or consequential damages of any kind or nature whatsoever arising out of or in any way related to the furnishing, performance, or use of this technical data. ZMD AG hereby expressly disclaims any liability of ZMD AG to any customer, licensee or any other third party, and any such customer, licensee and any other third party hereby waives any liability of ZMD AG for any damages in connection with or arising out of the furnishing, performance or use of this technical data, whether based on contract, warranty, tort (including negligence), strict liability, or otherwise.</p>			

© 2011 Zentrum Mikroelektronik Dresden AG — Rev. 3.0

All rights reserved. The material contained herein may not be reproduced, adapted, merged, translated, stored, or used without the prior written consent of the copyright owner. The information furnished in this publication is **PRELIMINARY** and subject to changes without notice.

A²SI-Light 14 / A²SI-Light 16

Low End Device AS-Interface



Contents

1	Pin Description	7
2	Pin Configuration	7
3	Electrical Specification	8
3.1.	Absolute Maximum Ratings (Non Operating)	8
3.2.	Recommended Operating Conditions	9
3.3.	Quality Assurance.....	9
3.4.	DC and AC Characteristic of all Pins and Functions	10
3.4.1.	Digital input and output Pins	10
3.4.2.	AS-i Bus Load (Pins ASIP/ASIN and Power Supply Input VIN)	11
3.4.3.	Pins OSC1, OSC2.....	11
3.5.	Information Data for Development.....	12
4	Functional Description.....	14
4.1.	Functional Block Diagram.....	14
4.2.	Power Supply.....	14
4.3.	Receiver.....	14
4.4.	Transmitter.....	14
4.5.	Digital Logic	15
4.6.	Data I/O Ports	16
4.6.1.	Data Exchange Model.....	16
4.6.2.	PWM Function.....	16
4.7.	FID Input and LED Output Ports.....	18
5	Typical application circuit of A ² SI-L	19
6	Package Outline and Device Marking	20
7	Ordering Information	23
Appendix A:	Crystal Parameter	24
A.1	Parameter data of Crystal.....	24
A.2	Capacitance on PCB	24
Appendix B:	External Coil	25
B.1	Target Coil	25
B.2	Coil Modeling.....	25
B.3	Electronic Inductor.....	26
Appendix C:	EEPROM.....	27

A²SI-Light 14 / A²SI-Light 16

Low End Device AS-Interface



List of Figures

Figure 3-1: Data Output Schematic in Principle	10
Figure 3-2: Data Input Schematic in Principle	10
Figure 3-3: Receiver comparator threshold set-up in principle.....	12
Figure 3-4: Reset Behavior.....	13
Figure 4-1: Functional Block Diagram	14
Figure 4-2: A ² SI-L IC Data Exchange master call data model	16
Figure 4-3: PWM control.....	17
Figure 4-4: PWM Output Signal Timing.....	18
Figure 5-1: Typical application I.....	19
Figure 5-2: Typical application II.....	19
Figure 6-1: SOP14.....	20
Figure 6-2: SOP16.....	21
Figure 6-3: Marking A ² SI-L14	22
Figure 6-4: Marking A ² SI-L16	22
Figure A-1: Crystal oscillator equivalent circuit	24
Figure B-1: External Coil equivalent circuits.....	25

A²SI-Light 14 / A²SI-Light 16

Low End Device AS-Interface



List of Tables

Table 1.1: A ² SI-L14/ A ² SI-L16 Pin Description	7
Table 3.1: Absolute Maximum Ratings	8
Table 3.2: Recommended Operating Conditions	9
Table 3.3: Crystal Properties ¹	9
Table 3.4: Input Voltages and Currents: Pins DI2, DI3, FID, TEST1/2 ¹	10
Table 3.5: Output Voltages and Currents: Pins DO0, DO1, LED	10
Table 3.6: AS-i Bus Interface Properties	11
Table 3.7: Oscillator Pins	11
Table 3.8: Information Data	12
Table 4.1: A ² SI-L Master Calls and Related Slave Responses	15
Table 4.2: PWM specification of Outputs: Pins DO0, DO1	17
Table A.1: 16 MHz crystals	24
Table A.2: Crystal models	24
Table C.1: Contents of the A ² SI-L14 / A ² SI-L16 EEPROM	27



1 Pin Description

Table 1.1 shows the pin description for both the A²SI-L14 and the A²SI-L16 IC. The graphical representations (pin-out symbols) are shown in chapter 2.

Table 1.1: A²SI-L14/ A² SI-L16 Pin Description

Pin# SOIC16	Pin# SOIC14	Name	Description
1	1	ASIPOS	positive ASI supply, high voltage supply
2	2	ASINEG	negative ASI supply
3	3	TEST1	test mode input/output
4	4	TEST2	test mode input
5		FID	digital input
6	5	DI2	digital input
7	6	DI3	digital input
8	7	OSC1	crystal oscillator input
9	8	OSC2	crystal oscillator output
10	9	DO1	digital output
11	10	DO0	digital output
12		LED	digital output
13	11	GND	digital ground
14	12	CAP	regulator output
15	13	0V	analog ground
16	14	VIN	High voltage supply

2 Pin Configuration

There is only one die used for both the 14- and 16-pin-version of the A²SI-L. In the 14-pin-version, the internal ports FID and LED are not bonded to external pins.

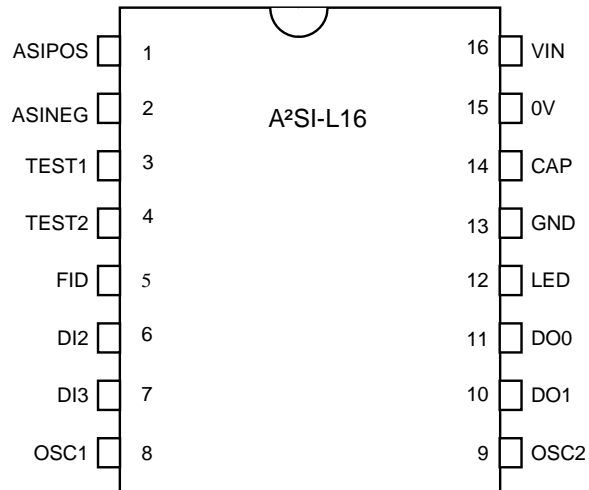

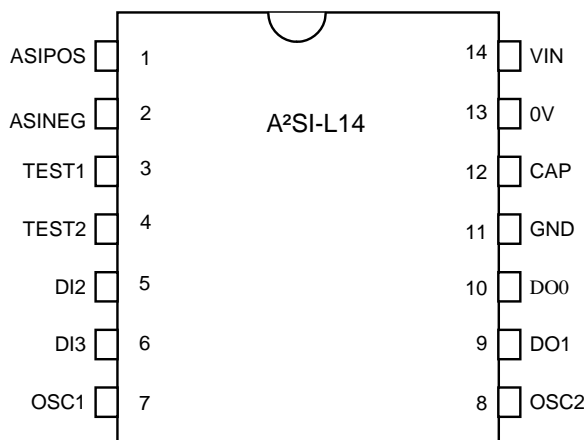

3 Electrical Specification

3.1. Absolute Maximum Ratings (Non Operating)

Table 3.1: Absolute Maximum Ratings

Symbol	Parameter	min	max.	Unit	Note
V0V ,VGND	Voltage reference	0	0	V	
VASIP	Positive AS-i supply voltage	-0.3	40	V	
VASIN	Negative AS-i supply voltage	-0.3	20	V	1
VASIP-ASIN	Voltage difference from ASIP to ASIN ($V_{ASIP} - V_{ASIN}$)	-0.3	40	V	2
VASIPP	AS-i supply pulse voltage, voltage difference between pins ASIP and ASIN (from ASIP to ASIN)		50	V	3
VVIN	Power supply input voltage	-0.3	40	V	
Vinputs1	Voltage at pins DI2, DI3, DO0, DO1, LED, FID	-0.3	VVIN + 0.3	V	
Vinputs2	Voltage at pins OSC1, OSC2, CAP, TEST1, TEST2	-0.3	7	V	
Iin	Input current into any pin except supply pins	-25	25	mA	
H	Humidity non-condensing				4
VHBM1	Electrostatic discharge – human body model (HBM1)	3000		V	5
VHBM2	Electrostatic discharge – human body model (HBM2)	2000		V	6
VEDM	Electrostatic discharge – equipment discharge model (EDM)	400		V	7
T _{STG}	Storage temperature	-55	125	°C	
Ptot	Total power dissipation		500	mW	8

¹ ASIN-pin shall be shorted to the 0V and GND pin on the PCB

² reverse polarity protection has to be performed externally

³ pulse with $\leq 50\mu s$, repetition rate ≤ 0.5 Hz

⁴ defined in DIN 40040 cond. F

⁵ HBM1: C = 100pF charged to VHBM1 with resistor R = 1.5kOhm in series, valid for ASIP-ASIN only.

⁶ HBM2: C = 100pF charged to VHBM2 with resistor R = 1.5kOhm in series, valid for all pins except ASIP-ASIN

⁷ EDM: C = 200pF charged to VEDM with no resistor in series, valid for ASIP-ASIN only

⁸ at max. operating temperature, the allowed total power dissipation depends on the additional thermal resistance from case to ambient and on the operation ambient temperature.



3.2. Recommended Operating Conditions

Table 3.2: Recommended Operating Conditions

Symbol	Parameter	min	max.	Unit	Note
VVIN,1	Positive supply voltage	12	31.6	V	1
VVIN,2	Positive supply voltage	20	31.6	V	2
VASIN	Negative AS-i supply voltage	0	0	V	3
V _{0V} , V _{GND}	Negative supply voltage	0	0	V	
IVIN	Supply current at V _{VIN} = 30V		8.5	mA	4
ICL1	max. output sink current at pins DO0, DO1		15	mA	
T _{amb}	Ambient temperature range, operating range	-25	85	°C	

1 all operations without EEPROM-write access are allowed

2 necessary for operations with EEPROM-write access only (processing of ADRA and WID1 master calls, refer to [Table 4.1](#))

3 ASIN shall be shorted with 0V and GND in order to ensure proper functionality of transmitter circuit.

4 f_c = 16.000 MHz, no load at any pin, without reaction of the circuit, ASIN is short-circuit to 0V, V_{VIN} = 30V.

Table 3.3 describes the crystal parameter that shall be satisfied by the x-tal that is interconnected to the pins OSC1 and OSC2. Due to the fact that the crystal parameter do not represent the entire internal and external oscillator circuit at all practical tests must indicate whether a crystal may work in a certain application circuit (PCB) or not. Appendix A list certain types of crystals that are going to be used as reference devices.

Table 3.3: Crystal Properties¹

Symbol	Parameter	Nom.	Min.	Max.	Unit	Note
F _c	Crystal frequency	16000	F _c – 60 ppm	F _c + 60 ppm	kHz	
C _s	Series capacitor		5	13	fF	
R _s	Series resistor			65	Ohm	
C _p	Parasitic parallel capacitor			5	pF	
C _{load}	Crystal dedicated parallel load	15 ²			pF	

¹ Crystal properties according to the crystal manufacturer data sheet

² In order to keep the influence of the crystal to the network error rate low as possible it is recommended to keep the crystal dedicated load between 8 pF and 32 pF. The IC provides approximately a load capacity of about 10 pF to 15 pF (correct by design).

3.3. Quality Assurance

The quality of the IC will be ensured accordingly to the ZMDI quality standards.



3.4. DC and AC Characteristic of all Pins and Functions

All parameters are valid for the recommended range of $V_{ASIP} - V_{ASIN}$ and T_{AMB} . The devices are tested within the recommended range of $V_{ASIP} - V_{ASIN}$, $T_{AMB} = +25^{\circ}\text{C}$ (+ 85 °C and - 25°C on sample base only) unless otherwise stated. Unused input pins shall be connected to a suitable potential within the application circuit because there are no internal pull-up/down resistors. It is recommended to connect these pins either to 0V or via resistor to VIN.

In order to ensure a normal operation of the IC the pins TEST1 and TEST2 must be connected to ground potential (GND).

3.4.1. Digital input and output Pins

Controlled by a configuration flag that is stored inside the EEPROM the data output signals can be pulse width modulated (PWM, for information refer to chapter 4.6.2).

The functionality of the FID output port is described in chapter 4.7.

Table 3.4: Input Voltages and Currents: Pins DI2, DI3, FID, TEST1/2 ¹

Symbol	Parameter	Min	Max.	Unit	Note
V_{IL}	Voltage range for input "low" level	0	2.5	V	
V_{IH}	Voltage range for input "high" level	3.5	V_{VIN}	V	3
V_{HYST}	Hysteresis for switching level	0.25		V	2
I_{IL}	Current range for input "low" level	-20	-5	μA	
I_{IH}	Current range for input "high" level	-10	10	μA	$V_o = 5\text{V}$
I_{IHV}	Current range for high voltage input		2	mA	$V_o = 30\text{V}$

¹ TEST1/2 are inputs for test purposes only.

² switching level approx. 3V, i.e. 3V +/- V_{HYST} ; the maximum hysteresis is determined by (min.) V_{IH} – (max) V_{IL}

³ Valid for high voltage input pins DI2, DI3 and FID. The regular logic swing is 0 .. 5V although higher input voltages might be applied (refer to parameter V_{input1} in Table 3.1). In the case of input voltages that exceed 5V a significant higher input current will flow into the input that is caused by the input protection circuitry (refer to parameter I_{IHV} of Table 3.4 and Figure 3-2).

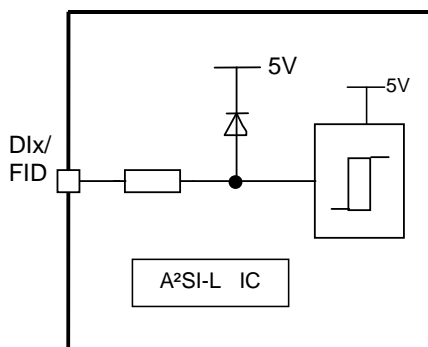

Figure 3-2: Data Input Schematic in Principle

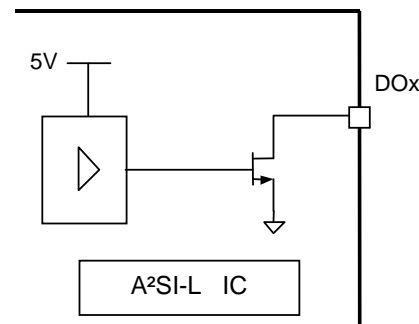

Figure 3-1: Data Output Schematic in Principle

Table 3.5: Output Voltages and Currents: Pins DO0, DO1, LED

Symbol	Parameter	Min	Max.	Unit	Note
V_{OL}	Voltage range for output "low" level		1	V	$I_{OL1} = 15\text{mA}$
I_{OH}	Output leakage current	-10	5	μA	$V_{OH} = 30\text{V}$



3.4.2. AS-i Bus Load (Pins ASIP/ASIN and Power Supply Input VIN)

The following parameters are determined with short-cut between the pins ASIN, GND, and 0V (GROUND). The pin VIN is connected to ASIP via an external coil. A decoupling capacitor has to be interconnected between VIN and GROUND as shown in Figure 4-1.

Table 3.6: AS-i Bus Interface Properties

Symbol	Parameter	min	max.	Unit	Note
ILIN	Input current limit at V _{IN}		25	mA	
VSIG	Input signal voltage difference between ASIP and ASIN	3	8	V _{PP}	
ISIG	Modulated output peak current from ASIP to ASIN	55	68	mA _P	
C _{zener}	Parasitic capacitance of the external over-voltage protection diode (Zener diode)		20	pF	1
RIN	Equivalent resistor of the ASIC	50		kOhm	1
CIN	Equivalent capacitor of the ASIC		15	pF	1

¹ The equivalent circuit of a slave has to satisfy the Complete AS-i Specification v.2.11 concerning the requirements for the extended address range. The input impedance as function of frequency is considered as correct by design.

3.4.3. Pins OSC1, OSC2

The on chip x-tal oscillator requires a 16 MHz crystal that must be interconnected to the pins OSC1 and OSC2. Internal capacitors make sure that no external capacitors from OSC1/OSC2 to ground are required. Furthermore no external capacitors shall be added to OSC1 and OSC2, respectively. Due to this parasitic capacitors shall be limited to C_{OSC} (Table 3.7). Appendix A shows the parameter of the crystal that is supposed to be used in A²SI-L IC application circuits.

Table 3.7: Oscillator Pins

Symbol	Parameter	Min	max.	Unit	Note
COSC	External parasitic capacitor at oscillator pins OSC1, OSC2	0	7	pF	
VIL	Input "low" voltage	0	1.5	V	1
VIH	Input "high" voltage	3.5	5	V	2

¹ for external clock applied to OSC1 only

² for external clock applied to OSC1 only



3.5. Information Data for Development

Table 3.8: Information Data

Symbol	Parameter	min	max.	Unit	Note
V _{PORIF}	Falling edge of the internal 5V supply voltage that activates the internal power-on-reset signal	3	4	V	1
V _{PORIR}	Rising edge of the internal voltage 5V supply voltage that causes the deactivation of the internal power-on-reset signal what will cause the start of the INIT procedure	2.5	3.5	V	1
T _{shut}	Chip temperature that causes an overtemp shut down	125	160	°C	
V _{LSIGon}	Receiver comparator threshold level (refer to Figure 3-3)	45	50	%	related to amplitude of 1 st pulse
t _{reset1}	Reset time - either after the end bit of the sent out slave response that is related to a received master Call Reset AS-i-Slave - or after the IC has deactivated its power-on-reset signal		2	ms	1
T _{Low}	Power-on reset pulse width	4	6	us	1

¹ guaranteed by design only

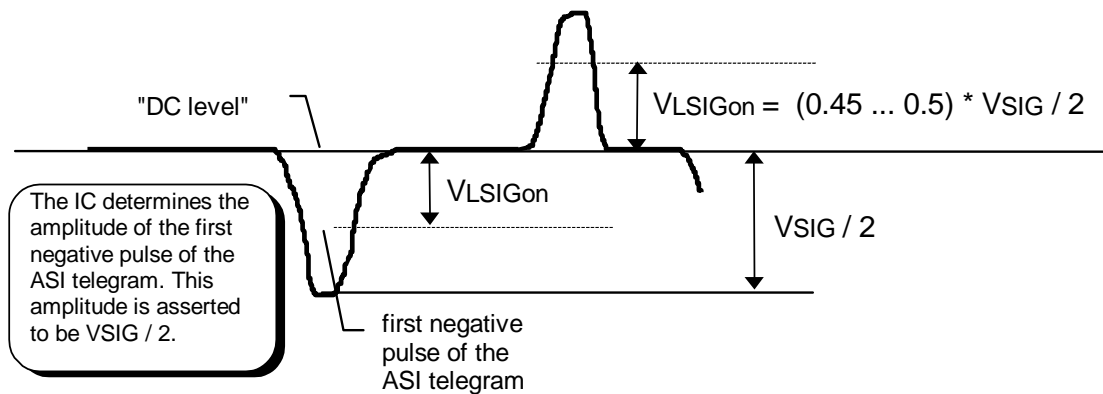

Figure 3-3: Receiver comparator threshold set-up in principle

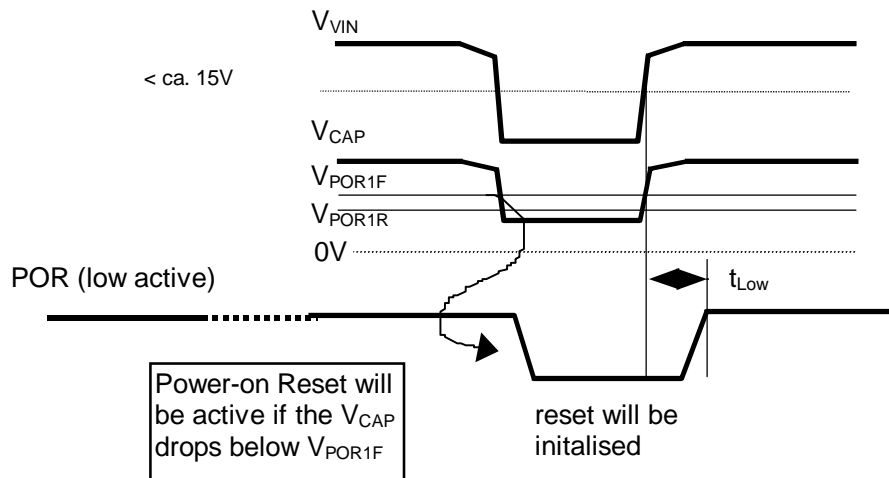

Figure 3-4: Reset Behavior

Note: The power-on reset circuit has a threshold voltage reference. This reference matches the process tolerance of the logic levels and is not required to be very accurate. All values depend slightly on the raise and fall time of the supply voltage.



4 Functional Description

4.1. Functional Block Diagram

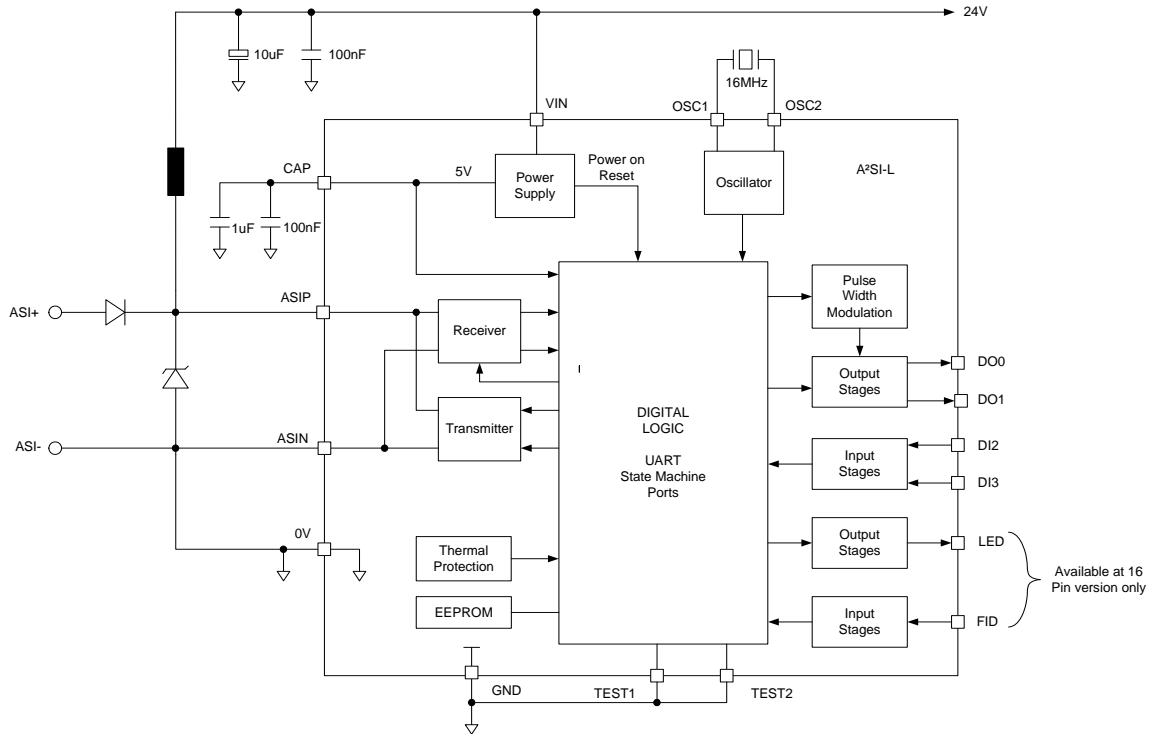

Figure 4-1: Functional Block Diagram

4.2. Power Supply

The power supply is derived from the AS-i line through an external reverse polarity protection diode and coil, and provided at pin VIN. An on-chip voltage regulator regulates the voltage at approximately 5V.

4.3. Receiver

The receiver detects the signals on the AS-i line and delivers the appropriate pulses to the digital logic. The DC value of the input signal is removed and the AC signal is band-pass filtered. This circuit is operating on both ASI+ and ASI- lines to take the differential nature of the signals into account. The digital output signals are extracted from the \sin^2 -shaped input pulses by a set of comparators. The maximum voltage of the first pulse determines the threshold level for all following pulses. This maximum value is digitally filtered to guarantee stable conditions (burst spikes have no effect). This approach combines a fast adaptation to changing signal amplitudes with a high detection safety. The receiver delivers the positive and negative pulses to the ASIC's logic. The logic resets the comparators after receiving with the REC_RESET signal. When the receiver is turned on the transmitter is turned off to reduce the power consumption.

4.4. Transmitter

The transmitter draws a modulated current between the ASI+ and ASI- pins to generate the communication signals. The shape of the current corresponds to the integral of a \sin^2 -function. The transmitter uses a current DAC and a high current driver. This driver must be activated before the transmission to achieve operating

A²SI-Light 14 / A²SI-Light 16

Low End Device AS-Interface



conditions. A small current is required which will be ramped up slowly to avoid any false voltage pulses on the AS-i line. The amount of circuitry between the ASI+ and ASI- pins is minimized to allow high impedance values. When the transmitter is turned on the receiver is turned off to reduce the power consumption.

4.5. Digital Logic

The digital logic block analyses the received signal, controls the reaction of the slave, transmits the slave response and switches the output ports.

Essential parts of the digital logic are as follows:

- The *UART* performs a syntactical analysis of the incoming master signal and executes the Manchester-coding of the outgoing slave answer.
- The *STATE MACHINE* controls the overall behavior of the slave. Depending on the configuration data provided by the EEPROM and the logic levels at the digital input ports it computes the contents of the slave answer where required. Table 4.1 lists all master calls that will be decoded by the **A²SI-L** IC. Moreover, the logic state of the digital output ports is controlled by the *STATE MACHINE* Chapters 4.6 as well as 4.7 contain more detailed descriptions of the digital I/O-ports.
- The *EEPROM* stores the non-volatile data of the **A²SI-L** circuit. A specification of the *EEPROM* contents is given in **Table C.1** on page 27. The meanings of some configuration flags are explained below and in Chapter 4.6, respectively.

By setting the *Program_Mode_Disable* flag (refer to **Table C.1**), the manufacturers of AS-i slave components may protect the entire firmware area – addresses 0x8 up to 0xC – against accidental overwriting.

The *Watchdog_Active* flag enables the internal communication watchdog. Once the communication was activated, it will trigger an unconditional reset as soon as it detects a data communication pause longer than 40ms. It should be noted that only the reception of a *Write Parameter (WPAR)* or *Data Exchange (DEXG)* master call can reset the watchdog.

Table 4.1: A²SI-L Master Calls and Related Slave Responses

Instruction	MNE	Master Request														Slave Response						
		ST	CB	A4	A3	A2	A1	A0	I4	I3	I2	I1	I0	PB	EB	SB	I3	I2	I1	I0	PB	EB
Data Exchange	DEXG	0	0	A4	A3	A2	A1	A0	0	D3 ~Sel	D2	D1	D0	PB	1	0	0 E3	0 E2	D1 E1	D0 E0	PB	1
Write Parameter	WPAR	0	0	A4	A3	A2	A1	A0	1	P3 ~Sel	P2	P1	P0	PB	1	0	P3 I3	P2 I2	P1 I1	P0 I0	PB	1
Address Assignment	ADRA	0	0	0	0	0	0	0	A4	A3	A2	A1	A0	PB	1	0	0	1	1	0	PB	1
Write Extended ID Code_1	WID1	0	1	0	0	0	0	0	0	ID3	ID2	ID1	ID0	PB	1	0	0	0	0	0	PB	1
Delete Address	DELA	0	1	A4	A3	A2	A1	A0	0	0 Sel	0	0	0	PB	1	0	0	0	0	0	PB	1
Reset Slave	RES	0	1	A4	A3	A2	A1	A0	1	1 ~Sel	1	0	0	PB	1	0	0	1	1	0	PB	1
Read IO Configuration	RDIO	0	1	A4	A3	A2	A1	A0	1	0 Sel	0	0	0	PB	1	0	IO3	IO2	IO1	IO0	PB	1
Read ID Code	RDID	0	1	A4	A3	A2	A1	A0	1	0 Sel	0	0	1	PB	1	0	ID3	ID2	ID1	ID0	PB	1
Read ID Code_1	RID1	0	1	A4	A3	A2	A1	A0	1	0 Sel	0	1	0	PB	1	0	ID3	ID2	ID1	ID0	PB	1
Read ID Code_2	RID2	0	1	A4	A3	A2	A1	A0	1	0 Sel	0	1	1	PB	1	0	ID3	ID2	ID1	ID0	PB	1
Read Status	RDST	0	1	A4	A3	A2	A1	A0	1	1 ~Sel	1	1	0	PB	1	0	S3	S2	S1	S0	PB	1
Broadcast (Reset)	BR01	0	1	1	1	1	1	1	1	0	1	0	1	PB	1	--- no slave response ---						
Enter Program Mode	PRGM	0	1	0	0	0	0	0	1	1	1	0	1	PB	1	--- no slave response ---						

Notes:



- In extended address mode the "Select Bit" defines whether the A- Slave or B- Slave is being addressed.
- The *Enter Program Mode* master call is intended for factory programming of the IC only. In order to achieve EEPROM firmware protection and in order to satisfy the AS-interface Complete Specification the call *Enter Program Mode* must be deactivated by setting the *Program_Mode_Disable* flag before shipment of the slave.

4.6. Data I/O Ports

4.6.1. Data Exchange Model

All *Data_Out* and *Data_In* signals are directly connected to the respective port (refer to Figure 4-2). The **A²SI-L** IC has only two data output pins (DO0 and DO1). Therefore the information bits I3 and I2 of the master call are not transferred to the **A²SI-L** data outputs. Since the **A²SI-L** IC has only two data input pins (DI2 and DI3) both lower order information bit (I1 and I0) of the slave response are set to "0" if the IC answers a *Data Exchange* master telegram.

If the EEPROM flag *Invert_Data_In* (refer to **Table C.1**) is set, all input data is inverted. This feature will simplify the circuitry for NPN-inputs.

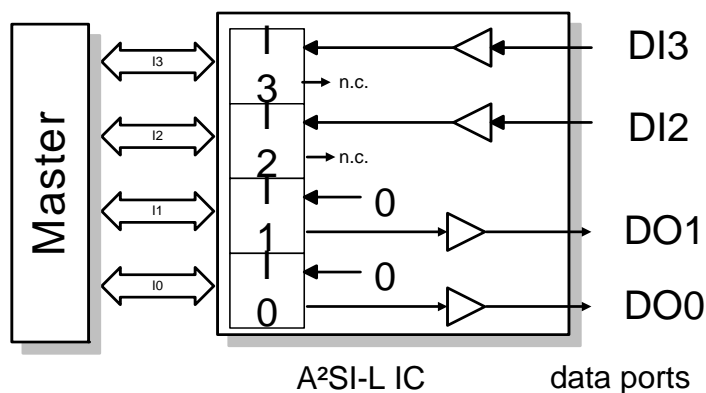

Figure 4-2: A²SI-L IC Data Exchange master call data model

The data input pins (DI2 and DI3) are sampled in a time frame that starts not earlier as the point in time of the end bit of the related *Data Exchange* master call and ends at least at the end of the start bit of the corresponding slave response. In the same time frame the data output pins will change their state if appropriated.

4.6.2. PWM Function

The regular function of the data pins DO0 and DO1 is to send out the corresponding master telegram data of the call *Data Exchange* (DEXG, refer to Table 3.5). DO0 corresponds to I0 and DO1 corresponds to I1. In addition to that the **A²SI-L** IC performs a PWM function which is dedicated for the brightness control of LEDs that are interconnected to DO0 and/or DO1, respectively. The PWM function may be enabled by the EEPROM flag *PWM_enable* (refer to **Table C.1**).



Table 4.2: PWM specification of Outputs: Pins DO0, DO1

Intensity of LED	"Write Parameter" command from Master ¹			PWM Frequency ² 1 / t _{PWM}	Pulse duty ratio ³ t _{on} / t _{PWM}
	P2	P1	P0		
100.00%	Select DO0 or DO1	1	1	DC (default)	16/16
50.00%	Select DO0 or DO1	0	1	125Hz	8/16
25.00%	Select DO0 or DO1	1	0	125Hz	4/16
12.50%	Select DO0 or DO1	0	0	125Hz	2/16

¹ The write parameter call is used to control the intensity of LEDs that are interconnect to the data output pins.

² Correct by design

³ Pulse/duty ratio is defined as the quotient t_{on} / t_{PWM} (refer to Table 4.1)

Provided that a lit LED is caused by a logic low level output signal of the related data pin brightness of the LED can be controlled by the master call *Write Parameter* (WPAR, refer to Table 4.1) as shown in Figure 4-3. After a *Write Parameter* call has been received the pulse duty ratio will be effective after the slave response has been sent. The default duty pause ration is 100% which is set after the initialization phase of the IC automatically. Figure 4-3 shows the telegram structure of the *Write Parameter* call. and the related slave response data.

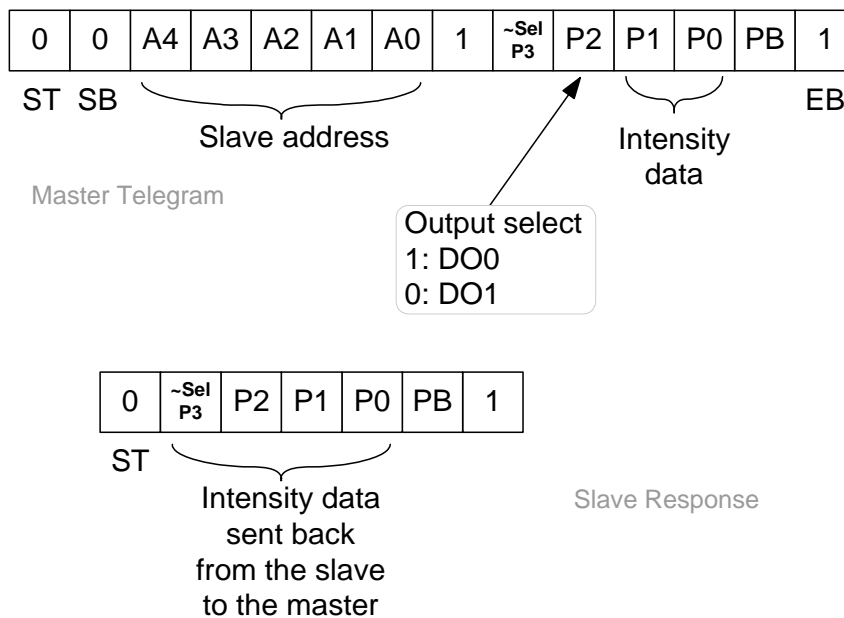

Figure 4-3: PWM control

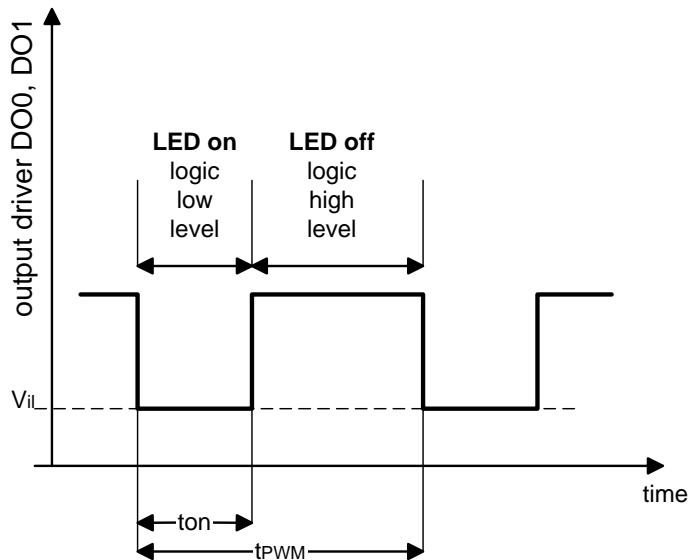

Figure 4-4: PWM Output Signal Timing

4.7. FID Input and LED Output Ports

The fault indication input FID is a digital input that is dedicated for a periphery fault messaging signal (for electrical properties refer to Table 3.4 on page 10). The S1 status bit is equivalent to the FID input signal. An FID transition will occur at S1 with a certain delay due to a synchronizer circuit which is put in between.

In case of the 14 pin IC version the FID input is not available. The manufacturer (ZMDI) will disable this function by setting the EEPROM flag *FID_Disable* (refer to **Table C.1**). A disabled FID pin function is equivalent to a logic low input signal at an enabled FID pin. Therefore the status bit S1 is always cleared if an IC is having a disabled FID pin.

The LED output port is used as a status indicator. An active FID (logic high) signal causes a flashing status LED (frequency approx. 2Hz). Otherwise, if FID is not active (logic low) the status LED operation depends on the communication status of the **A²SI-L** device. If the internal *Data_Exchange_Disable* flag is set (no data exchange allowed), a steady-on LED shall indicate that the communication is off.

Notes:

- An active FID has priority and will cause a flashing LED even if the *Data_Exchange_Disable* flag is set.
- If the FID pin is disabled (EEPROM flag *FID_Disable* set), the LED output is always set to logic high state.



5 Typical application circuit of A²SI-L

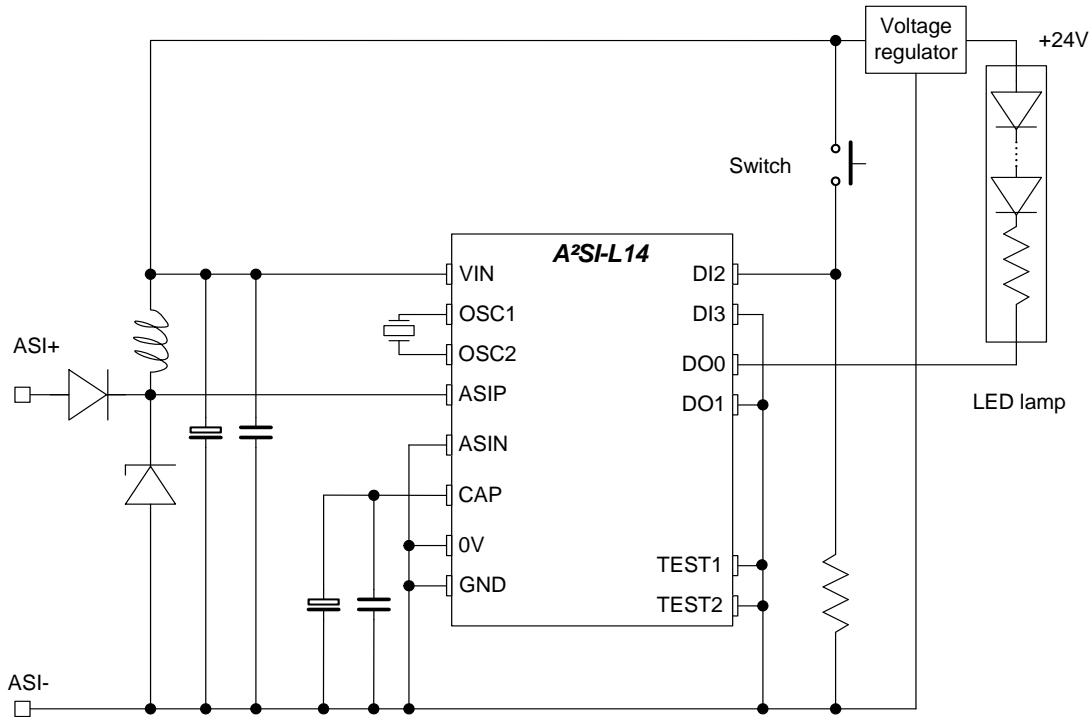

Figure 5-1: Typical application I

The pins ASIN, 0V and GND must be connected on the PCB.

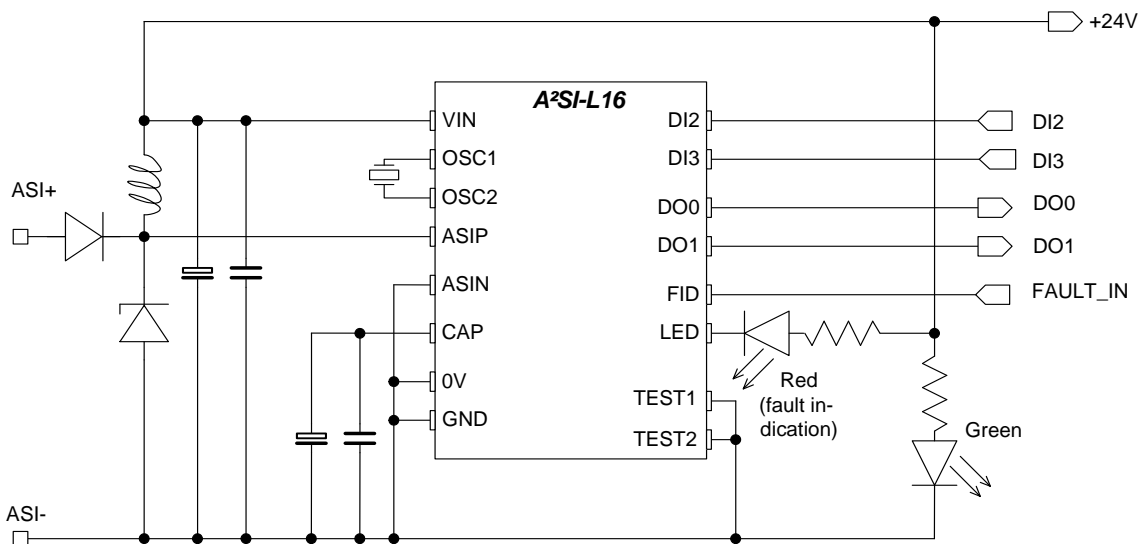

Figure 5-2: Typical application II

<p>Data Sheet October 20, 2011</p>	<p>© 2011 Zentrum Mikroelektronik Dresden AG — Rev. 3.0 All rights reserved. The material contained herein may not be reproduced, adapted, merged, translated, stored, or used without the prior written consent of the copyright owner. The information furnished in this publication is PRELIMINARY and subject to changes without notice.</p>	<p>19 of 27</p>
---	---	-----------------



6 Package Outline and Device Marking

The IC is available in a 14 or 16 pin SOIC-package. Dimensions are shown in Figure 6-1 and Figure 6-2. Figure 6-3 and Figure 6-4 indicate the device marking.

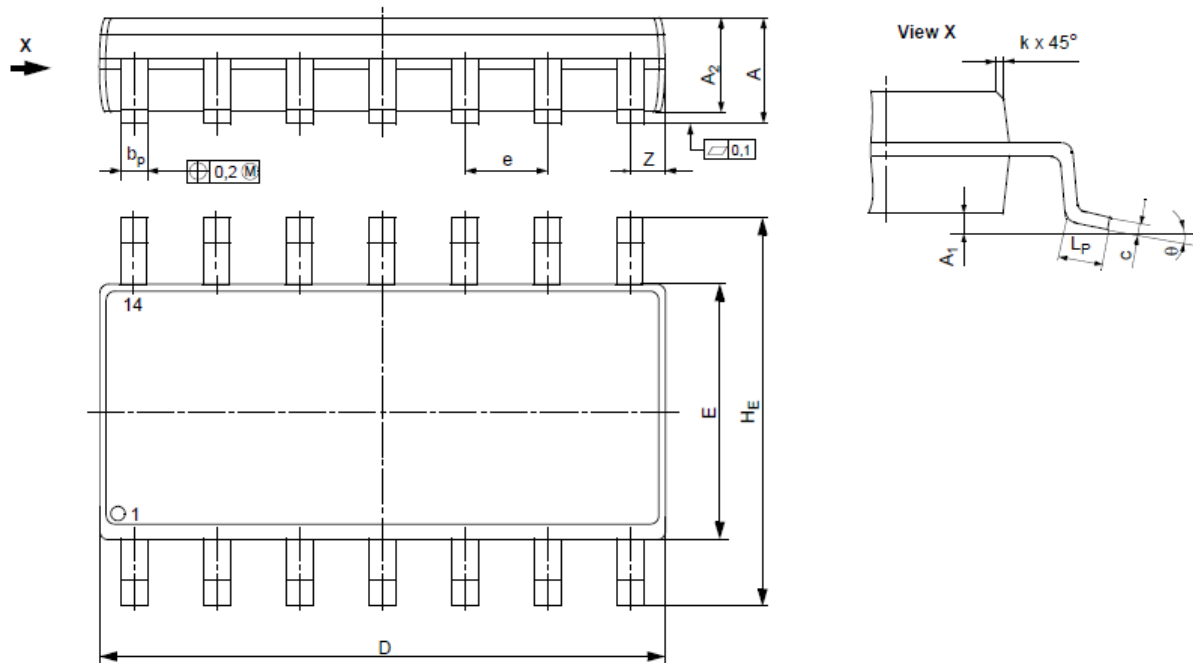

Dimensions of Sub-Group B1	
A_{max}	1,73
b_{Pmin}	0,35
b_{Pmax}	0,49
e_{nom}	1,27
H_{Emin}	5,80
H_{Emax}	6,30
L_{Pmin}	0,40
Z_{max}	0,56

Dimensions of Sub-Group C1	
A_{min}	1,55
A_{1min}	0,127
A_{1max}	0,25
A_{2min}	1,40
A_{2max}	1,55
c_{min}	0,19
c_{max}	0,25
D_{min}^*	8,58
D_{max}^*	8,74
E_{min}^*	3,80
E_{max}^*	4,00
k_{min}	0,25
θ_{min}	0°
θ_{max}	8°

- 2 Weight $\leq 0,5$ g
- 3 Package Body Material Low Stress Epoxy
- 4 Lead Material FeNi-Alloy or Cu-Alloy
- 5 Lead Finish solder plating
- 6 Lead Form Z-bends

* without mold-flash

Figure 6-1: SOP14

A²SI-Light 14 / A²SI-Light 16

Low End Device AS-Interface

ZMDI[®]

The Analog Mixed Signal Company

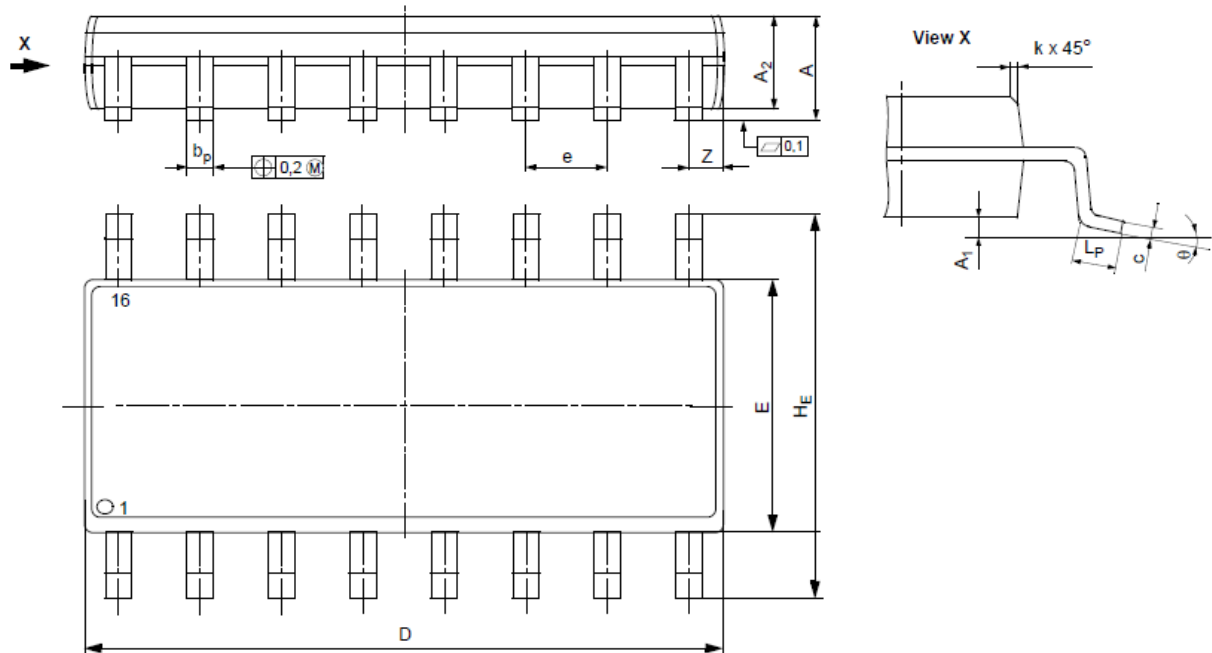

Dimensions of Sub-Group B1	
A_{max}	1,73
b_{Pmin}	0,35
b_{Pmax}	0,49
e_{nom}	1,27
H_{Emin}	5,80
H_{Emax}	6,30
L_{Pmin}	0,40
Z_{max}	0,55

Dimensions of Sub-Group C1	
A_{min}	1,55
A_{1min}	0,127
A_{1max}	0,25
A_{2min}	1,40
A_{2max}	1,55
c_{min}	0,19
c_{max}	0,25
D_{min}^*	9,80
D_{max}^*	9,98
E_{min}^*	3,80
E_{max}^*	4,00
k_{min}	0,25
θ_{min}	0°
θ_{max}	8°

- 2 Weight $\leq 0,5$ g
- 3 Package Body Material Low Stress Epoxy
- 4 Lead Material FeNi-Alloy or Cu-Alloy
- 5 Lead Finish solder plating
- 6 Lead Form Z-bends

* without mold-flash

Figure 6-2: SOP16

A²SI-Light 14 / A²SI-Light 16

Low End Device AS-Interface

ZMDI[®]

The Analog Mixed Signal Company

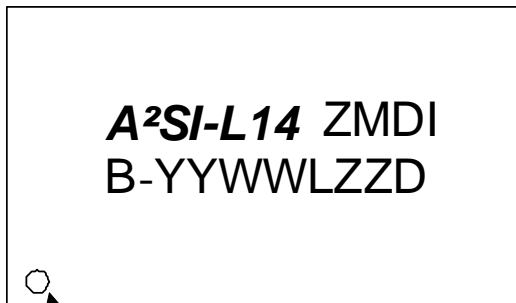

Pin 1 mark

A²SI-L14: Product Name
ZMDI: Manufacturer
B: Revision Code
YYWW: Year / Workweek (Datecode)
L: Assembly Location
ZZD: Traceability and Status Code

Figure 6-3: Marking A²SI-L14

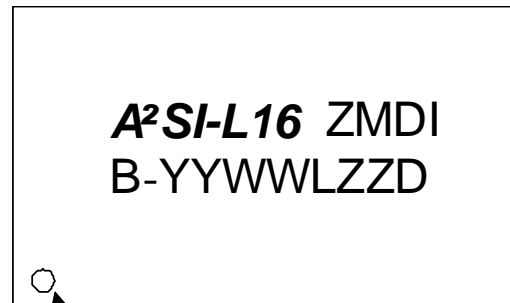

Pin 1 mark

A²SI-L16 : Product Name
ZMDI: Manufacturer
B: Revision Code
YYWW: Year / Workweek (Datecode)
L: Assembly Location
ZZD: Traceability and Status Code

Figure 6-4: Marking A²SI-L16

A²SI-Light 14 / A²SI-Light 16

Low End Device AS-Interface

ZMDI[®]

The Analog Mixed Signal Company



7 Ordering Information

Ordering Code	Product Description	Packaging
A2SI-L14-ST	A ² SI-Lite 14 pin SOP 150 mil package (without diagnostic pins)	Tube
A2SI-L14-SR		Tape & Reel
A2SI-L16-ST	A ² SI-Lite 16 pin SOP 150 mil package (with diagnostic pins)	Tube
A2SI-L16-SR		Tape & Reel



Appendix A: Crystal Parameter

A.1 Parameter data of Crystal

Different crystals types are described in Table A.1. The models of those crystals are described in Table A.2.

Table A.1: 16 MHz crystals

Symbol	Model	Maker	Size W* D* H (mm)	Operating Temperature Range (°C)
A	LIM-T-16.000	Kyusyu Dentsu Co.	7.5*5.0*1.2	-25 ... +85
B	LAP-16.000	Kyusyu Dentsu Co.	6.0*3.5*1.2	-25 ... +85
C	SXN-A 16 MHz	Nippon Industries	6.0*3.5*1.2	-40 ... +85
D	SXH-A 16 MHz	Nippon Industries	7.5*5.0*1.0	-40 ... +85
E	DSX630G	Daishinku corp.	6.0*3.5*1.2	-25 ... +85

Table A.2: Crystal models

Symbol	L1 (mH)			C1 (fF)			R1 (Ohm)			C0 (pF)			CL (pF)		
	Min.	Typ.	Max.	Min.	Typ.	Max.	Min.	Typ.	Max.	Min.	Typ.	Max.	Min.	Typ.	Max.
A	6.7	7.9	9.1	9.0	10.6	12.2	-	-	60.0	2.4	2.9	3.3	12.0	16.0	20.0
B	7.9	9.3	10.7	9.0	10.6	12.2	-	-	60.0	2.4	2.9	3.3	12.0	16.0	20.0
C	7.9	9.3	10.7	9.0	10.6	12.2	-	10.0	60.0	2.4	2.9	3.3	8.0	-	32.0
D	6.7	7.9	9.1	9.0	10.6	12.2	-	10.0	60.0	2.4	2.9	3.3	8.0	-	32.0
E	14.1	16.6	19.1	5.1	6.0	6.9	10.0	50.0	-	1.8	2.1	2.4	12.0	-	20.0

Note: A crystal is fabricated for a dedicated load capacitor. This load capacitor CL is equivalent to the sum of CL' (internal oscillator circuit capacitor) and the parasitic capacitor CP (capacity that is caused by the PCB, e.g. by copper areas and wires on the PCB).

Figure A-1 shows an equivalent circuit of the crystal oscillator that should illustrate the modeling method.

A.2 Capacitance on PCB

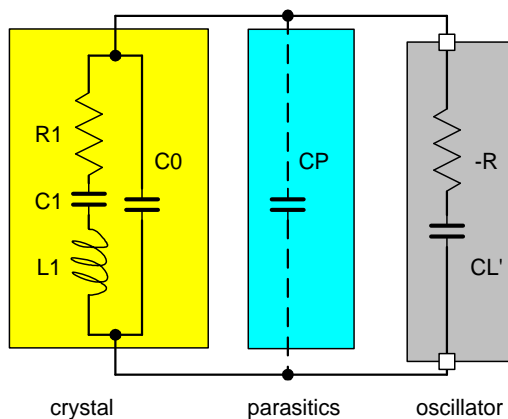

Figure A-1: Crystal oscillator equivalent circuit



Appendix B: External Coil

B.1 Target Coil

In order to satisfy the Complete Specification AS-interface an application circuit has to achieve a certain input impedance. Besides the A²SI-L IC properties the applied external coil will have an significant influence. Therefore a suitable coil shall be recommended. During the product development period recommended data of this coil have to be worked out. The following coil is considered as target component and shall be applied (between ASIP and VIN, refer to Figure 5-1 and Figure 5-2, respectively) as long no other recommendation has been made:

Coil No, SD75-183k

Core No, M5D DR7.8*5.0 DIM

Maker EASY MAGNET Corp. <http://www.easymagnet.com.tw>

Inductance: 18mH +-10% (f=1kHz Ambient Temperature : 20°C DC Bias 0A)

DC resistance : Max 72.0 ohm (Ambient Temperature :20°C DC Bias 0A)

B.2 Coil Modeling

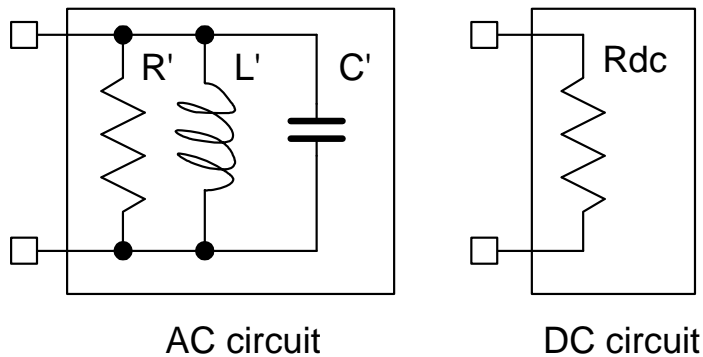

Figure B-1: External Coil equivalent circuits

Figure B-1 shows the model parameters that will be used in order to recommend suitable external coils. Until the end of the development process the following parameters have shall be recommended by ZMDI:

L' : Real value of Inductance

C' : Parasitic capacitor

R' : AC Resistance

Rdc : DC Resistance

Measurement frequency : 50k...300kHz C' R' L'



B.3 Electronic Inductor

ZMDI provides an optional application (see separate application note) for a bipolar (GND free) electronic inductor* to replace a mechanical coil with some inexpensive electronic parts. This solution save costs, board space and will be more resistant against mechanical vibrations. This inductor provides a supply current up to 90mA to V_{in} and the connected circuit, respectively.

Zentrum Mikroelektronik Dresden AG provides a license to ZMDI AS-Interface IC customers free of charge.

* patent pending

For further information, please contact:

ZMD AG
BL Standard Components
Grenzstrasse 28
01109 Dresden, Germany
asi@ZMDI.com



Appendix C: EEPROM

Table C.1: Contents of the A²SI-L14 / A² SI-L16 EEPROM

EEPROM Address	Bit Position	EEPROM Cell Content	EEPROM Register Content
0x0	0 ... 3	A0 ... A3	Slave Address low nibble
0x1	0	A4	Slave Address high nibble
0x1	1 ... 3	(not useable)	none
0x2	0 ... 3	ID1_0 ... ID1_3	ID code extension 1
0x3	0 ... 3	Not implemented - do not access	
0x4 ... 0x7	0 ... 3	Not implemented - do not access	
0x8	0 ... 3	ID_0 ... ID_3	ID code
0x9	0 ... 3	ID2_0 ... ID2_3	ID code extension 2
0xA	0 ... 3	IO_0 ... IO_3	IO code
0xB	0	PWM_enable	Configuration Flags
0xB	1	PWM_32k_mode	
0xB	2	Reserved	
0xB	3	Reserved	
0xC	0	FID_Disable	Configuration Flags
0xC	1	Program_Mode_Disable	
0xC	2	Watchdog_Active	
0xC	3	Invert_Data_In	
0xD	0 ... 3	Not implemented - do not access	
0xE	0 ... 3	Trimm Information, do not access	
0xF	0 ... 3	Trimm Information, do not access	