

Copyright FCI.

rev	ecn no	dr	date
P	S50184	BSL	1995-09-19
R	S60082	BSL	1996-03-26
S	S70073	BSL	1997-03-25
T	V94400	BSL	1999-12-01
U	S05-0059	KBN	2005-04-20
V	S09-0253	NBR	2009-08-25
W	S10-0136	NBR	2010-06-28

www.fciconnect.com			surface -	tolerance std	projection	<b>CONFIDENTIAL</b>	
Dr	BS LOW	2000-01-06	ISO 1302	ISO 406 ISO 1101	MM / INCH		
Eng	BS LOW	2000-01-06	TOLERANCES UNLESS OTHERWISE SPECIFIED			size	Scale
Chr	KH LEE	2010-06-28	ANGULAR	0.X ±0.3	A3	10:1	
Appr	JOEY NG	2010-06-28	LINEAR	0.XX ±0.13	ECN	S10-0136	
			0° ±2°	0.XXX ±0.051	Spec ref	-	
			Product family		LPVCC		
			Title		LOW PROFILE VCC	91596	Rev.
			catalog no		CUSTOMER	sheet 1 of 2	W

REV F - 2006-04-11

PDM: Rev:W STATUS:Released Printed: Nov 27, 2010

PRODUCT NO	POSITIONS	DIM. A	DIM. B
91596-X04	2 X 2	2.00 / .079	3.92 / .154
-X06	2 X 3	4.00 / .158	5.92 / .233
-X08	2 X 4	6.00 / .236	7.92 / .312
-X10	2 X 5	8.00 / .315	9.92 / .391
-X12	2 X 6	10.00 / .394	11.92 / .469
-X14	2 X 7	12.00 / .472	13.92 / .548
-X16	2 X 8	14.00 / .551	15.92 / .627
-X18	2 X 9	16.00 / .630	17.92 / .706
-X20	2 X 10	18.00 / .709	19.92 / .784
-X22	2 X 11	20.00 / .787	21.92 / .863
-X24	2 X 12	22.00 / .866	23.92 / .942
-X26	2 X 13	24.00 / .945	25.92 / 1.020
-X28	2 X 14	26.00 / 1.024	27.92 / 1.099
-X30	2 X 15	28.00 / 1.102	29.92 / 1.178

CONTACT AREA PLATING OPTIONS	
0	= 0.20µm/8µ" Au CONTACT AREA.
1	= 0.76µm/30µ" Au CONTACT AREA.
3	= 0.38µm/15µ" Au CONTACT AREA.

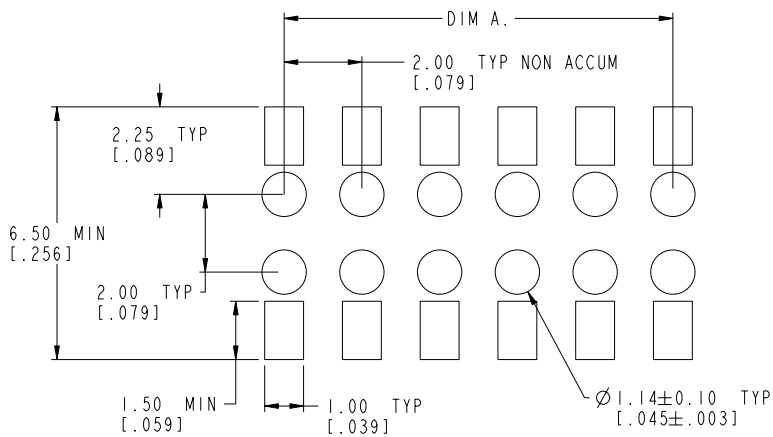

RECOMMENDED PAD LAYOUT

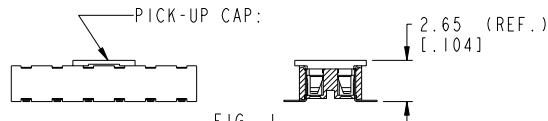

FIG. 1  
NOTE 6 (b) & (d)

- NOTES:
- HOUSING MAT'L : HIGH TEMP PLASTIC.
  - TERMINAL MAT'L : BeCu.
  - TERMINAL RETENTION 0.5Kg/1.1 Lbs.
  - 'V' CUT OPTIONAL - MANUFACTURING PROCESS OPTION.
  - PRODUCT DESCRIPTION CODE:

XXXXX-X XXLF



6. PACKAGING:
- XXXXX-XXX ---STD PACKAGING IN TUBE.
  - XXXXX-XXXTR ---TAPE AND REEL (CONDUCTIVE) PACKAGING WITH PICK-UP CAP (SEE FIG 1).
  - XXXXX-XXXTRN ---TAPE AND REEL (CONDUCTIVE) PACKAGING WITHOUT PICK-UP CAP.
  - XXXXX-XXXCR ---TAPE AND REEL (NON-CONDUCTIVE) PACKAGING WITH PICK-UP CAP (SEE FIG 1).
  - XXXXX-XXXCRN ---TAPE AND REEL (NON-CONDUCTIVE) PACKAGING WITHOUT PICK-UP CAP.

- (7) SOLDER TAILS PLATING:
- SOLDERTAIL OF P/N:91596-XXX IS TIN/LEAD PLATED.
  - SOLDERTAIL OF P/N:91596-XXXLF IS GOLD FLASH PLATED.
8. THE HOUSING WILL WITHSTAND EXPOSURE TO 255°C PEAK TEMPERATURE FOR 10 SECONDS IN A CONVECTION, INFRA-RED OR VAPOR PHASE REFLOW OVEN.
- (9) THIS PRODUCT MEETS EUROPEAN UNION DIRECTIVES AND OTHER COUNTRY REGULATIONS AS DESCRIBED IN GS-22-008.

- (W) 10. A (W) SYMBOL WILL BE NEXT TO ANY DIMENSION, VIEW OR NOTE WHICH HAS BEEN MODIFIED WITH THE CURRENT DRAWING REVISION.

CONFIDENTIAL

Material	SEE NOTES	Spec ref	-	surface	tolerance	projection	MM / INCH
Mat code	SEE NOTES	ISO 1302	ISO 406	ISO 1101	ISO 1101	MM / INCH	MM / INCH
Heatreat	-	ISO 1302	ISO 406	ISO 1101	ISO 1101	MM / INCH	MM / INCH
Plating/Finish	SEE NOTES	ISO 1302	ISO 406	ISO 1101	ISO 1101	MM / INCH	MM / INCH
Dr	BS LOW	2000-01-06	Product family	LPVCC	size	A3	Scale 10:1
Eng	BS LOW	2000-01-06	Model Name	91596.X12	ECN	S10-0136	Rev. W
Chr	KH LEE	2010-06-28	Model Revision	-	REL Level	-	91596
Appr	JOEY NG	2010-06-28	Model Revision	-	REL Level	-	91596
FCI title	LOW PROFILE VCC	Part no	91596	Rev.	W	sheet 2 of 2	
Pro/E file	catalog no	CUSTOMER					