

PROPER USE GUIDELINES

Cumulative Trauma Disorders can result from the prolonged use of manually powered hand tools. AMP hand tools are intended for occasional use and low volume applications. AMP offers a wide selection of powered application equipment for extended-use, production operations.

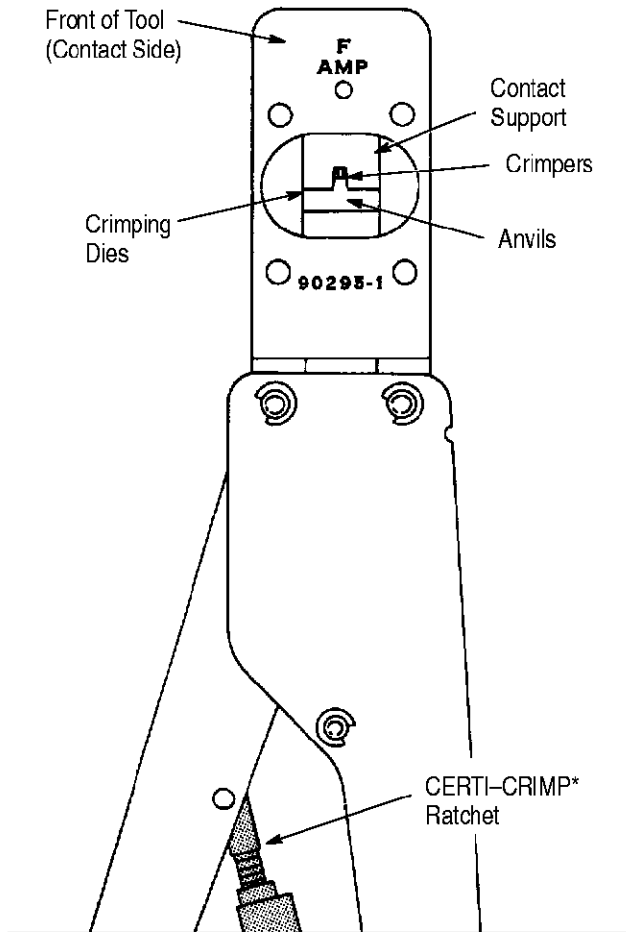

Figure 1

1. INTRODUCTION

AMP* Hand Crimping Tool 90295-1 is designed to crimp the AMP Locking Clip loose piece (LP) contact listed in Figure 2. Read these instructions thoroughly before using the hand tool.

NOTE

Measurements are in millimeters [followed by inch equivalents in brackets]. Figures and illustrations are for identification only and are not drawn to scale.

Reasons for reissue are in Section 6, REVISION SUMMARY.

2. DESCRIPTION (Figure 1)

The front of the tool (contact side), into which the contact is inserted, has the tool number marked on it. The back of the tool (wire side), into which the wire is

inserted, has the wire size marked above the crimp section.

The hand tool features two fixed dies (crimpers), two movable dies (anvils), a contact support, a contact locator, a wire stop, an ejector, and a CERTI-CRIMP ratchet.

The contact support prevents the contact from bending during the crimping procedure.

The contact locator positions the contact between the crimping dies. In use, it rests in the locator slot. See Figure 2.

The wire stop aids in locating the wire in the contact.

The ejector pulls the locator down and ejects the crimped contact when the tool handles are fully opened.

The CERTI-CRIMP ratchet ensures full crimping of the contact. Once engaged, the ratchet will not release until the tool handles have been FULLY closed.

CAUTION

The crimping dies bottom before the CERTI-CRIMP ratchet releases. This is a design feature that ensures maximum electrical and tensile performance of the crimp. Do NOT re-adjust the ratchet.

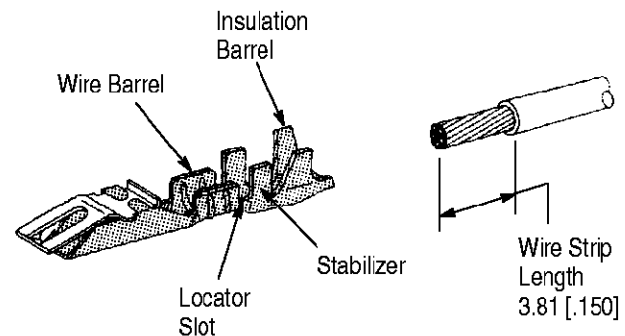

NOTE: Not to Scale

WIRE SIZE (AWG)	INSUL DIA RANGE	CONTACT PART NUMBER	
		LP	STRIP
28 to 30	0.74-0.99 [.029-.039]	87191-[]	87190-[]

Figure 2

3. CRIMPING PROCEDURE

Refer to Figure 2 and select wire of the specified size and insulation diameter. Strip the wire to the length indicated. Do not cut or nick the wire strands.

Proceed as follows:

1. Hold tool so that the BACK (wire side) is facing you. See Figure 3.
2. Make certain that the ratchet is released by squeezing the tool handles and allowing them to open FULLY.
3. Looking straight into the BACK of the crimp section, insert the contact (insulation barrel first) into the FRONT of the crimp section.
4. Position the contact in the crimpers so that the locator enters the locator slot. See Figure 3.
5. Next, push the contact in until the WIRE BARREL butts against the contact locator. See Figure 4.
6. Hold the contact in this position and squeeze the tool handles until the insulation anvil starts entry into the insulation crimper.

CAUTION

Squeezing the handles together too much will deform the insulation barrel or wire barrel.

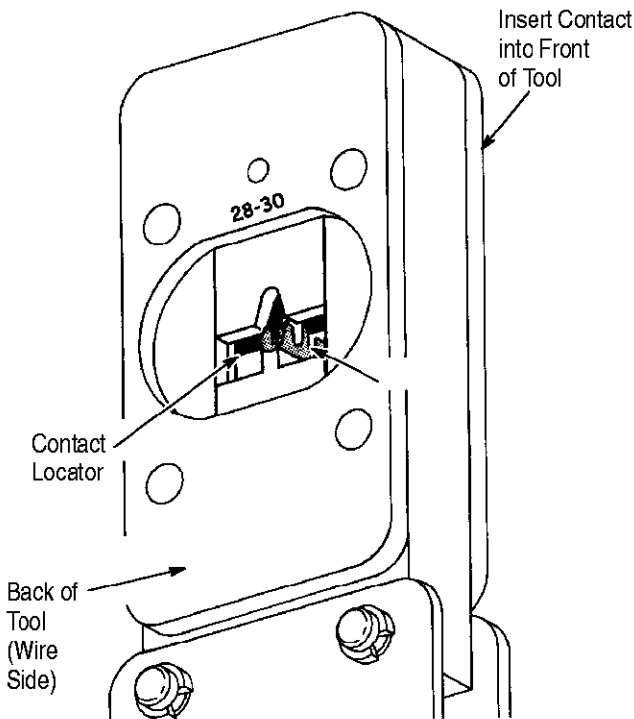

Figure 3

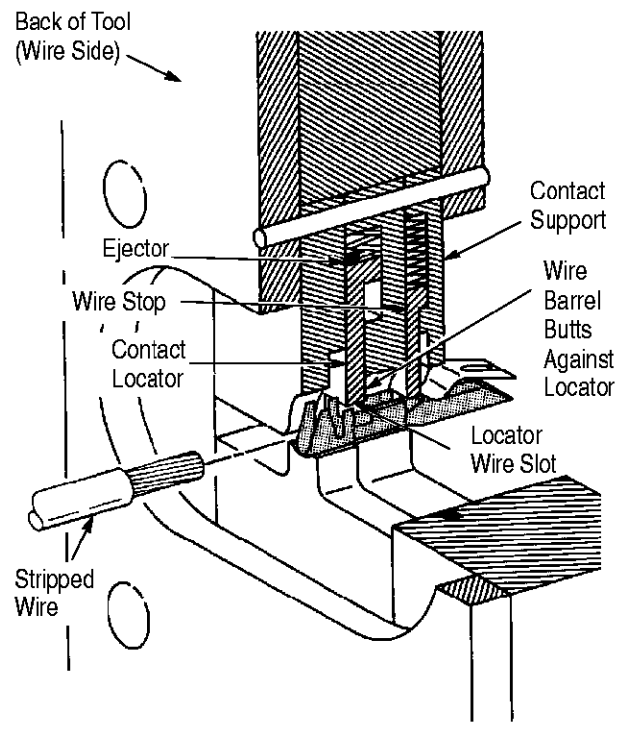

Figure 4

7. Insert a properly stripped wire through the locator wire slot and into the wire barrel of the contact until it butts against the wire stop. See Figure 4.

8. Hold the wire in place and squeeze the tool handles until the ratchet releases.

9. Allow the tool handles to open FULLY so that the ejector can push the contact out of the crimpers. Remove the crimped contact from the tool.

4. MAINTENANCE AND INSPECTION PROCEDURE

AMP recommends that a maintenance and inspection program be performed periodically to ensure dependable and uniform terminations. Though recommendations call for at least one inspection a month, frequency of inspection depends on:

1. The care, amount of use, and handling of the hand tool.
2. The presence of abnormal amounts of dust and dirt.
3. The degree of operator skill.
4. Your own established standards.

The hand tool is inspected before being shipped; however, AMP recommends that the tool be inspected immediately upon arrival to ensure that the tool has not been damaged during shipment.

4.1. Daily Maintenance

1. Hand tool should be immersed (handles partially closed) in a reliable commercial degreasing compound to remove accumulated dirt, grease, and foreign matter. When degreasing compound is not available, tool may be wiped clean with a soft, lint-free cloth. Do NOT use hard or abrasive objects that could damage the tool.
2. Make certain that the retaining pins are in place and that they are secured with retaining rings.
3. All pins, pivot points, and bearing surfaces should be protected with a THIN coat of any good SAE 20 motor oil. Do not oil excessively.
4. When the tool is not in use, keep handles closed to prevent objects from becoming lodged in the crimping dies. Store the tool in a clean, dry area.

4.2. Periodic Inspection

A. Lubrication

Lubricate all pins, pivot points, and bearing surfaces with SAE 20 motor oil as follows:

- Tool used in daily production – lubricate daily
- Tool used daily (occasional) – lubricate weekly
- Tool used weekly – lubricate monthly

Wipe excess oil from tool, particularly from crimping area. Oil transferred from the crimping area onto certain terminations may affect the electrical characteristics of an application.

B. Visual Inspection

1. Close tool handles until ratchet releases and then allow them to open freely. If they do not open quickly and fully, the spring is defective and must be replaced. See Section 5, REPLACEMENT AND REPAIR.
2. Inspect head assembly for worn, cracked, or broken dies. If damage is evident, return the tool to AMP for evaluation and repair. See Section 5, REPLACEMENT AND REPAIR.

C. Crimp Height Inspection

This inspection requires the use of a modified micrometer with a modified anvil and spindle, as shown in Figure 5. AMP recommends the Crimp Height Comparator RS-1019-5LP which can be purchased from:

Shearer Industrial Supply Co. VALCO
 20 North Penn Street or 1410 Stonewood Drive
 York, PA 17401-1014 Bethlehem, PA 18017-3527

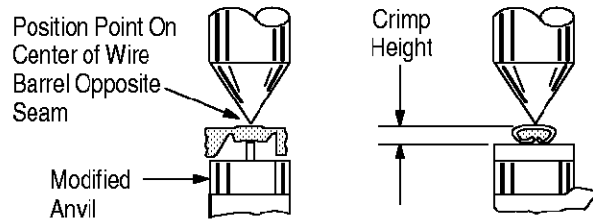

CONTACT NUMBER	WIRE SIZE (AWG) (Max)	CRIMP SECTION WIRE SIZE MARKING	CRIMP HEIGHT DIMENSION
87191	28	28 - 30	0.99 ± 0.05 [.039 ± .002]

Figure 5

Proceed as follows:

1. Refer to the table in Figure 2 and determine the maximum wire size and the applicable contact for the tool.
2. Refer to Section 3, CRIMPING PROCEDURE, and crimp the contact(s) accordingly.
3. Using a crimp height comparator, measure the wire barrel crimp height as shown in Figure 5. If the crimp height conforms to that height, the tool is considered dimensionally correct. If not, the tool must be returned to AMP for evaluation and repair. See Section 5, REPLACEMENT AND REPAIR.

For additional information concerning the use of the crimp height comparator, refer to AMP instruction sheet 408-7424.

D. CERTI-CRIMP Ratchet Inspection

The CERTI-CRIMP ratchet feature on AMP hand tools should be checked to ensure that the ratchet does not release prematurely, allowing the dies to open before they have fully bottomed. Obtain a 0.025 [.001] shim that is suitable for checking the clearance between the bottoming surfaces of the crimping dies. Proceed as follows:

1. Select a contact and maximum size wire. See Figure 2.
2. Position the contact and wire between the crimping dies, as described in Section 3, CRIMPING PROCEDURE.
3. Hold the wire in place and squeeze the handles until the CERTI-CRIMP ratchet releases. Hold the handles in this position, maintaining just enough tension to keep the dies closed.

4. Check the clearance between the bottoming surfaces of the crimping dies. If the clearance is 0.025 [.001] or less, the ratchet is satisfactory. If clearance exceeds 0.025 [.001], the ratchet is out of adjustment and must be repaired. See Section 5, REPLACEMENT AND REPAIR.

CUSTOMER SERVICE (38-35)
AMP INCORPORATED
P.O. BOX 3608
HARRISBURG, PA 17105-3608

For tool repair service, please contact an AMP representative at 1-800-526-5136.

5. REPLACEMENT AND REPAIR

Replacement parts are listed in Figure 6. Parts other than those listed in Figure 6 should be replaced by AMP to ensure quality and reliability of the tool. Order replacement parts through your AMP representative, or call 1-800-526-5142, or send a facsimile of your purchase order to 1-717-986-7605, or write to:

6. REVISION SUMMARY

Since the previous release of this sheet, the following changes were made:

Per EC 0990-1228-99

- Updated document to corporate requirements
- Changed document title
- Changed tool repair service information in Section 5, REPLACEMENT AND REPAIR

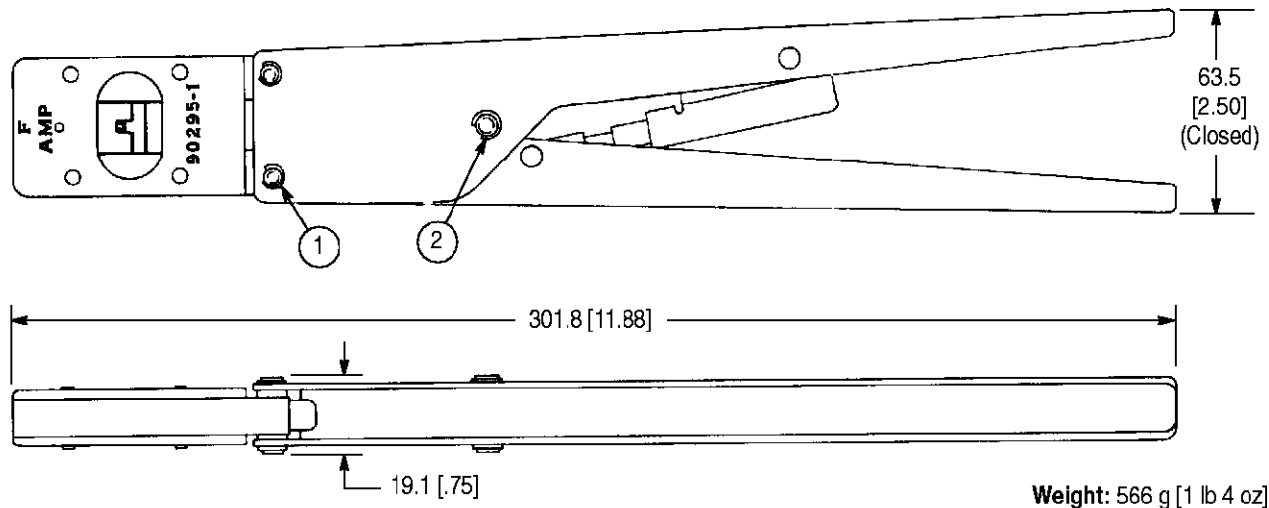

REPLACEMENT PARTS

ITEM	PART NUMBER	DESCRIPTION	QTY PER TOOL
1	21045-3	RING, Retaining	4
2	21045-6	RING, Retaining	2

Figure 6