

PROPER USE GUIDELINES

Cumulative Trauma Disorders can result from the prolonged use of manually powered hand tools. Hand tools are intended for occasional use and low volume applications. A wide selection of powered application equipment for extended-use, production operations is available.

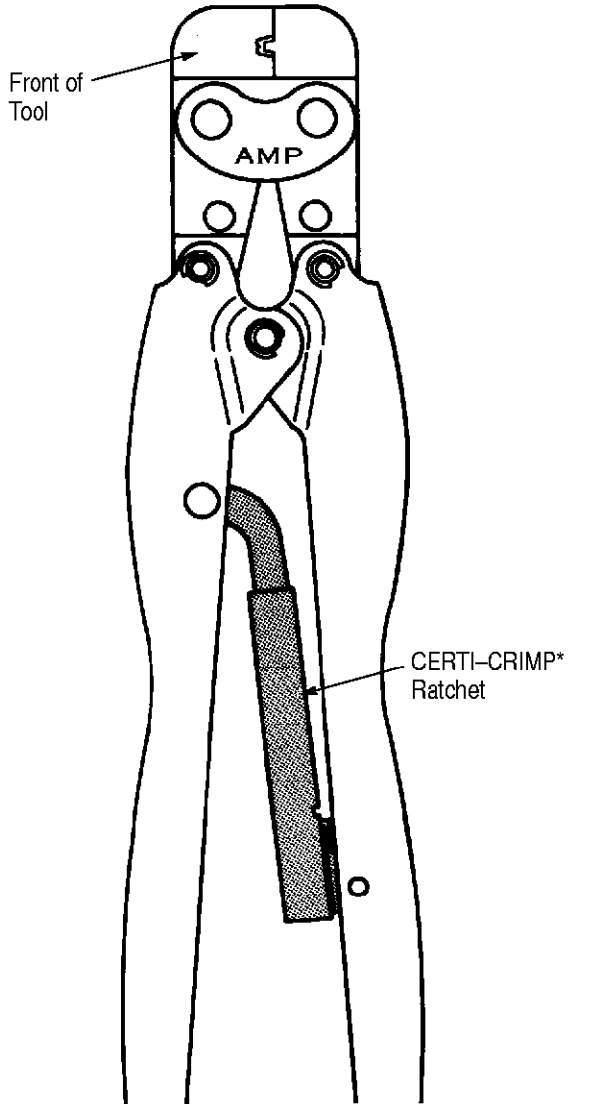

Figure 1

1. INTRODUCTION

AMP* Hand Crimping Tool 90227-1 is designed to crimp the loose piece (LP) FASTON* terminal listed in Figure 2. Read these instructions thoroughly before crimping any terminals.

NOTE All dimensions in this document are in metric units [with U.S. customary units in brackets]. Figures and illustrations are for identification only and are not drawn to scale.

Reasons for reissue of this instruction sheet are provided in Section 6, REVISION SUMMARY.

2. DESCRIPTION

This tool features a terminal locator/insulation stop and a CERTI-CRIMP ratchet.

The terminal locator/insulation stop positions the terminal between the crimping jaws. In addition, the locator/insulation stop aids in locating the wire in the terminal. In use, it rests in the terminal locator slot. See Figures 2 and 3.

The CERTI-CRIMP ratchet ensures full crimping of the terminal. Once engaged, the ratchet will not release until the tool handles have been fully closed.

CAUTION The crimping jaws bottom before the CERTI-CRIMP ratchet releases. This is a design feature that ensures maximum electrical and tensile performance of the crimp. Do NOT re-adjust the ratchet.

3. CRIMPING PROCEDURE

Refer to the chart in Figure 2 and select wire within the specified wire size and insulation diameter. Strip the wire to the length indicated -do NOT cut or nick the wire strands.

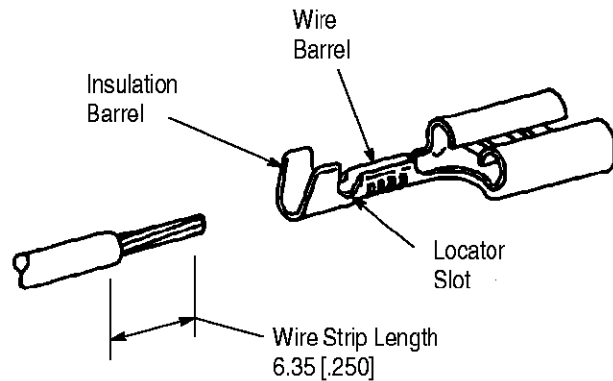

WIRE		TERMINAL NUMBER (LP)
SIZE (AWG)	INSULATION DIAMETER	
24 to 20	0.76 to 1.78 [0.030 to .070]	61368

Figure 2

Select an applicable terminal and proceed as follows:

1. Hold the tool so that the back (wire side) is facing you.
2. Make sure that the ratchet is released. Squeeze the tool handles together and allow them to open fully.
3. Looking straight into the back of the tool, insert the terminal (insulation barrel first) into the front of the crimp section. See Figure 3.
4. Position the terminal in the crimping area so that the locator/insulation stop enters the locator slot in the terminal.
5. Hold the terminal in this position and squeeze the tool handles together until the insulation anvil starts entry into the insulation crimper. Do NOT deform the insulation barrel or wire barrel.
6. Insert a properly-stripped wire through the wire slot of the locator and into the wire barrel of the terminal until the wire insulation butts against the locator/insulation stop.
7. While holding the wire in place, squeeze the tool handles together until the ratchet releases.
8. Allow the tool handles to open fully and remove the crimped terminal.

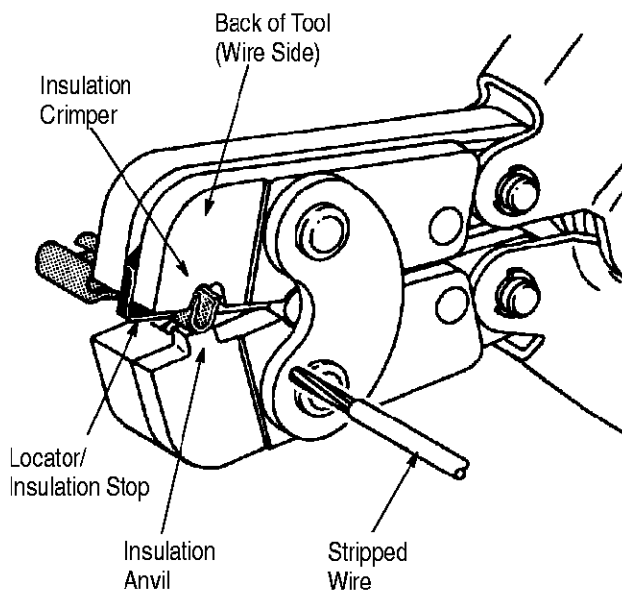

Figure 3

4. MAINTENANCE/INSPECTION

4.1. Daily Maintenance

Remove all foreign particles with a clean, soft brush or a clean, soft, lint-free cloth. Make sure the proper retaining pins are in place and are secured with the proper retaining rings. If foreign matter cannot be removed easily, or if the proper replacement parts are not available, return the tool to your supervisor.

Make sure all pivot points and bearing surfaces are protected with a thin coat of any good SAE 20 motor oil. Do NOT oil excessively. When the tool is not in use, keep the handles closed to prevent objects from becoming lodged between the jaws, and store the tool in a clean, dry area.

4.2. Periodic Inspection

Regular inspection should be performed by quality control personnel. A record of scheduled inspections should remain with the tool and/or be supplied to the supervisory personnel responsible for the tool. Though recommendations call for at least one inspection a month, the inspection frequency should be based on the amount of use, ambient working conditions, operator training and skill, and established company standards. These inspections should be performed in the following sequence:

A. Visual Inspection

1. Remove all lubrication and accumulated film by immersing the tool (handles partially closed) into a suitable degreaser that will not affect paint or plastic material.
2. Make certain all retaining pins are in place and are secured with the proper retaining rings. If replacements are necessary, refer to Figure 5.
3. Close the tool handles until the ratchet releases, and then allow the handles to open freely. If they do not open quickly and fully, then the spring is defective and must be replaced (see Section 5, REPLACEMENT AND REPAIR).
4. Inspect the tool, with special emphasis on checking for worn, cracked, or broken crimping jaws. If damage to any part of the head is evident, return the tool for evaluation and repair (see Section 5, REPLACEMENT AND REPAIR).

B. Crimp Height Inspection

This inspection requires the use of a micrometer, with a modified anvil, as shown in Figure 4. The Crimp Height Comparator RS-1019-5LP is recommended and is available from:

Shearer Industrial Supply Co. 20 North Penn Street York, PA 17401-1014	or	VALCO 1410 Stonewood Drive Bethlehem, PA 18017-3527
--	----	---

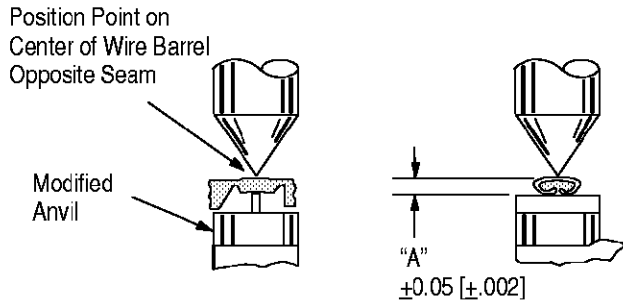

TERMINAL NUMBER	WIRE SIZE AWG (Max.)	CRIMP HEIGHT DIM. "A"
61368	20	1.27 [.050]

Figure 4

Proceed as follows:

1. Refer to the chart in Figure 4 and select a terminal and a wire (maximum size) for the hand tool.
2. Refer to Section 3, CRIMPING PROCEDURE, and crimp the terminal accordingly.
3. Using a crimp height comparator, measure the wire barrel crimp height as shown in Figure 4. If the crimp height conforms to that shown in the chart, the tool is considered dimensionally correct. If not, return the tool for evaluation and repair (refer to Section 5, REPLACEMENT AND REPAIR).

For additional information concerning the use of the crimp height comparator, refer to Instruction Sheet 408-7424.

C. CERTI-CRIMP Ratchet Inspection

Obtain a 0.025 [.001] shim that is suitable for checking the clearance between the bottoming surfaces of the crimping jaws. Proceed as follows:

1. Select a terminal and *maximum* size wire for the hand tool.

2. Position the terminal and wire between the crimping jaws, as described in Section 3, CRIMPING PROCEDURE.
3. Holding the wire in place, squeeze the tool handles together until the CERTI-CRIMP ratchet releases. Hold the handles in this position, maintaining just enough tension to keep the jaws closed.
4. Check the clearance between the bottoming surfaces of the crimping jaws. If the clearance is 0.025 [.001] or less, the ratchet is satisfactory. If the clearance exceeds 0.025 [.001], the ratchet is out of adjustment and must be repaired.

If the tool conforms to these inspection procedures, lubricate it with a thin coat of any good SAE 20 motor oil and return it to service.

5. REPLACEMENT AND REPAIR

The parts listed in Figure 5 are customer-replaceable. A complete inventory can be stocked and controlled to prevent lost time when replacement of parts is necessary. Order replacement parts through your Tyco Electronics representative, or call 1-800-526-5142, or send a facsimile of your purchase order to 1-717-986-7605, or write to:

CUSTOMER SERVICE (38-35)
TYCO ELECTRONICS CORPORATION
P.O. BOX 3608
HARRISBURG, PA 17105-3608

Tools may be returned for evaluation and repair. For tool repair service, contact a representative at 1-800-526-5136.

6. REVISION SUMMARY

Per EC 0990-0214-00:

- Changed tool repair service information in Section 5, REPLACEMENT AND REPAIR
- Updated document format

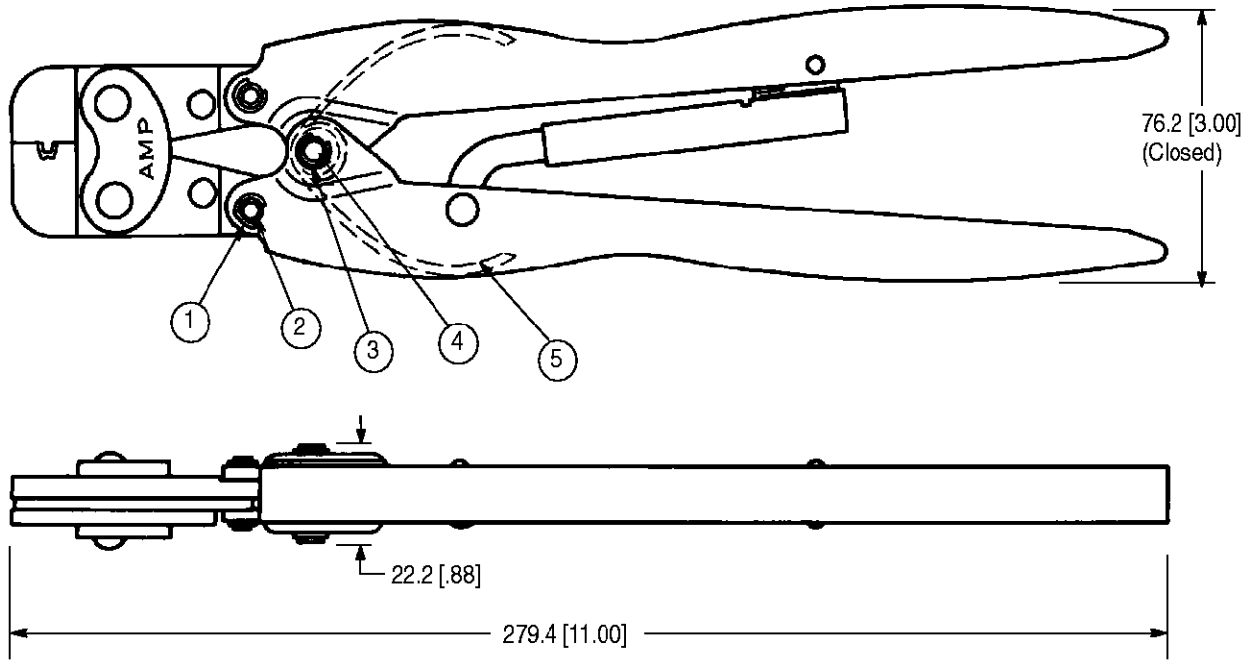

WEIGHT: 539 g [1 lb 3 oz.]

REPLACEMENT PARTS			
ITEM	PART NUMBER	DESCRIPTION	QTY PER TOOL
1	21045-3	Ring, Retaining	4
2	300432	Pin, Retaining	2
3	21045-6	Ring, Retaining	2
4	300449	Pin, Retaining	1
5	39364	Spring, Handle	1

Figure 5