

**AMP**AMP INCORPORATED  
HARRISBURG, PA 17105APPLICATION AND MAINTENANCE  
FOR AMP\* HAND CRIMPING  
TOOL 90206-3**IS 7343**CUSTOMER HOTLINE  
1 800 722-1111RELEASED  
3-14-88*Section I of this instruction sheet provides application procedures for AMP hand crimping tools.**Section II provides maintenance and inspection procedures for AMP hand crimping tools.*

Fig. I-1

**SECTION I APPLICATION****I-1. INTRODUCTION**

AMP Hand Crimping Tool 90206-3 is designed to crimp the Taper Pin loose-piece (LP) terminals listed in Figure I-2. Read these instructions carefully before proceeding.

**NOTE**

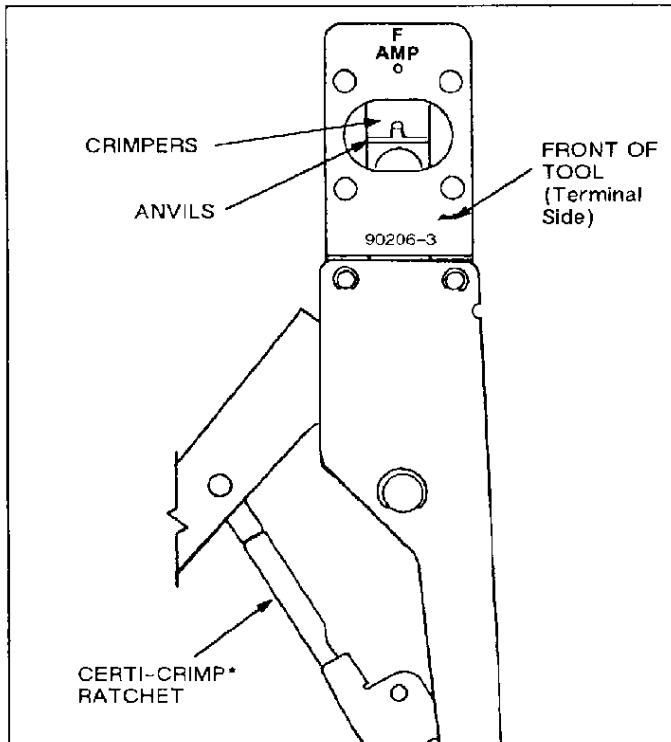
*All dimensions on this instruction sheet are in inches.*

**I-2. DESCRIPTION (Figures I-1 and I-3)**

This tool features two fixed dies (crimpers), two movable dies (anvils), a locator/insulation stop, a terminal support, and a CERTI-CRIMP ratchet.

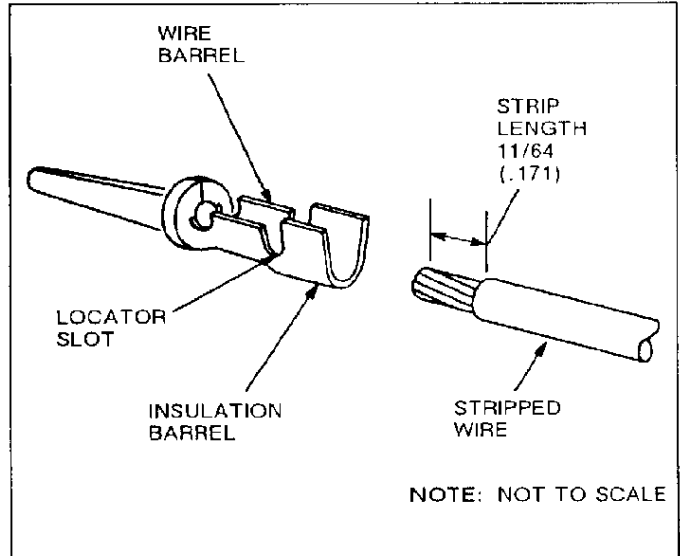

Fig. I-2

| WIRE SIZE RANGE (AWG) | INSUL DIA RANGE (IN.) | LOOSE-PIECE TERMINAL NO. |
|-----------------------|-----------------------|--------------------------|
| 30 to 26              | .030 to .050          | 66354                    |

The locator/insulation stop positions the terminal between the crimping dies and aids in locating the wire in the terminal. In use, it rests in the terminal's locator slot. Refer to Figure I-3.

The terminal support prevents the terminal from bending during the crimping procedure. The ejector ejects the crimped terminal once the handles have been FULLY opened.

The CERTI-CRIMP ratchet assures full crimping of the terminal. Once engaged, the ratchet will not release until the handles have been FULLY closed.

**CAUTION**

*The crimping dies bottom before the CERTI-CRIMP ratchet releases. This is a design feature that assures maximum electrical and tensile performance of the crimp. Do NOT re-adjust the ratchet.*

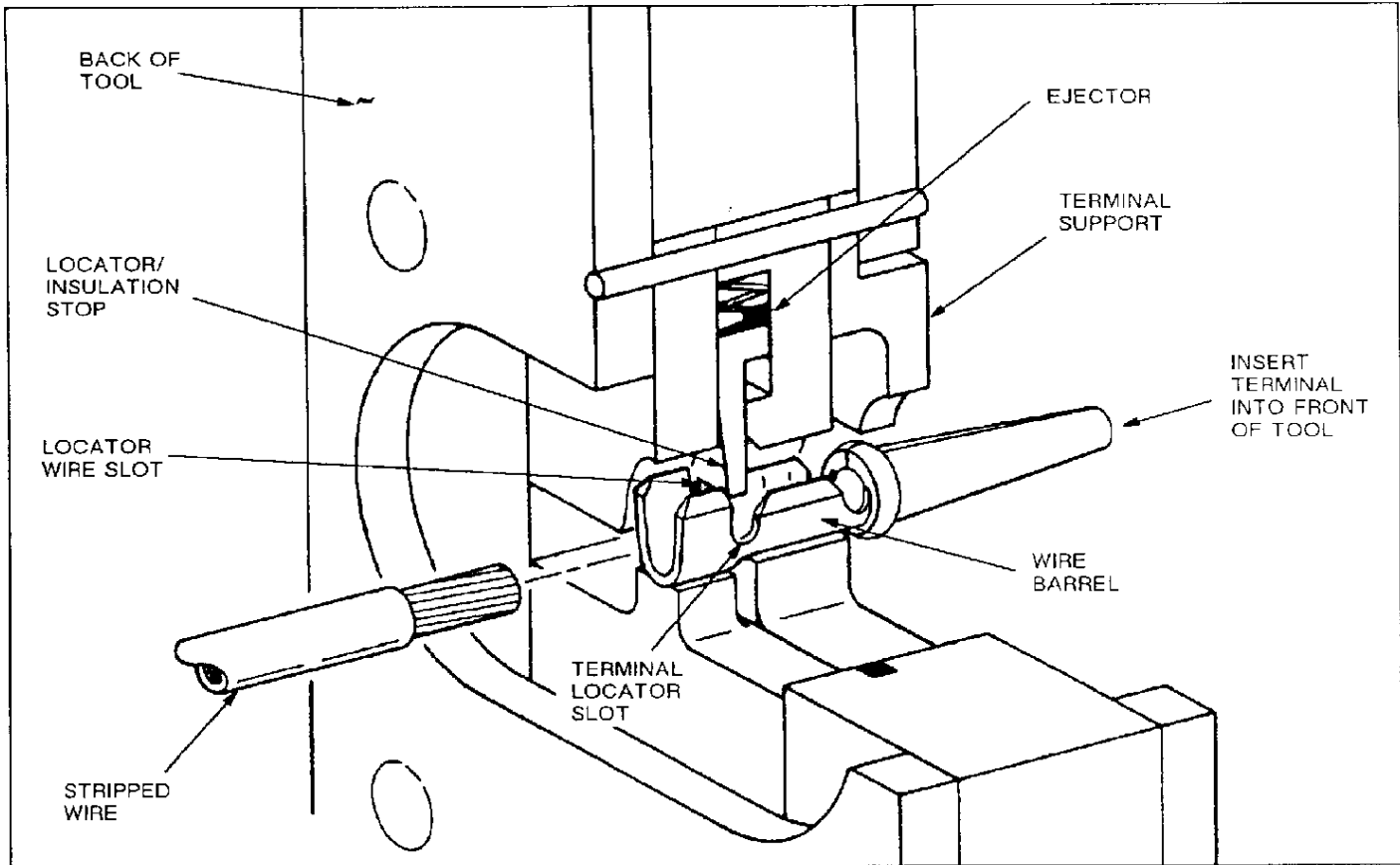

Fig. I-3

### I-3. CRIMPING PROCEDURE

Refer to the chart in Figure I-2, and then select wire of the specified size and insulation diameter. Strip the wire to the length indicated — do NOT cut or nick the wire strands.

#### NOTE

*This tool is designed to crimp only the loose-piece terminals listed in Figure I-2. Do NOT use the tool to crimp single terminals that have been cut from a strip.*

Select an appropriate terminal and proceed as follows:

1. Hold the tool so the BACK of it is facing you. See Figure I-3.
2. Make certain that the ratchet is released by squeezing the tool handles and allowing them to open FULLY.
3. Looking straight into the crimping dies from the BACK of the tool, insert a terminal (insulation barrel first) into the FRONT of the tool. See Figure I-3.
4. Position the terminal in the crimpers so that the locator enters the locator slot.

5. Hold the terminal in this position and squeeze the tool handles until the insulation anvil starts entry into the insulation crimper. Do NOT deform the insulation barrel or wire barrel.

6. Insert the stripped wire through the locator/insulation stop slot until the wire insulation butts against the stop and the bare wire extends into the wire barrel of the terminal.

7. Hold the wire in place and squeeze the tool handles until the ratchet releases.

8. Allow the tool handles to open FULLY and remove the crimped terminal.

### I-4. DAILY MAINTENANCE

Remove all foreign particles with a clean, soft brush or a clean, soft, lint-free cloth. Make sure the proper retaining pins are in place and secured with the proper retaining rings. If foreign matter cannot be removed easily, or if the proper replacement parts are not available, return the tool to your supervisor.

Make certain all pivot points and bearing surfaces are protected with a THIN coat of any good SAE No. 20 motor oil. Do NOT oil excessively. When the tool is not in use, keep the handles closed to prevent objects from becoming lodged between the crimping dies, and store the tool in a clean, dry area.

Section I of this instruction sheet provides application procedures for AMP hand crimping tools.

Section II provides maintenance and inspection procedures for AMP hand crimping tools.

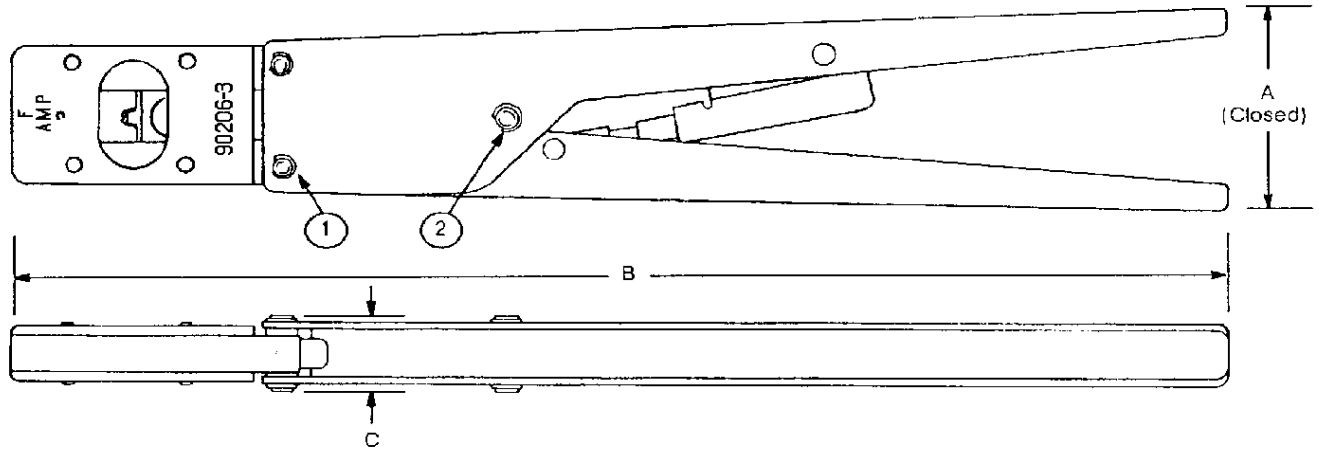

| TOOL SPECIFICATIONS |           | CUSTOMER-REPLACEABLE PARTS |             |                 |     |
|---------------------|-----------|----------------------------|-------------|-----------------|-----|
| DIMENSION           | WEIGHT    | ITEM                       | PART NUMBER | DESCRIPTION     | QTY |
| A                   | 1 lb 4 oz | 1                          | 21045-3     | RING, Retaining | 4   |
| B                   |           | 2                          | 21045-9     | RING, Retaining | 2   |
| C                   |           |                            |             |                 |     |

**CAUTION** DO NOT REMOVE THE RETAINING PINS AS PERMANENT DAMAGE TO THE TOOL COULD RESULT (See Paragraph II-2).

Fig. II-1

**SECTION II MAINTENANCE/INSPECTION**

These instructions have been approved by AMP Design, Production, and Quality Control Engineers to provide documented maintenance and inspection procedures in accordance with AMP Corporate Policy No. 3-3. Through AMP test laboratories and the inspection of production assembly, the procedures described herein have been established to ensure quality and reliability of AMP hand crimping tools.

Customer-replaceable parts are listed in Figure II-1. A complete inventory should be stocked and controlled to prevent lost time when replacement of parts is necessary. When replacement parts are needed, order by part number and description.

**II-1. INSPECTION PROCEDURES**

**A. Daily Maintenance**

It is recommended that each operator of the tool be made aware of — and responsible for — the following four steps of daily maintenance:

1. Remove dust, moisture, and other contaminants with a clean brush or a soft, lint-free cloth. Do NOT use objects that could damage the tool.
2. Make sure the proper retaining pins are in place and secured with the proper retaining rings.
3. Make certain all pins, pivot points, and bearing surfaces are protected with a THIN coat of any good SAE No. 20 motor oil. Do NOT oil excessively.
4. When the tool is not in use, keep the handles closed to prevent objects from becoming lodged in the crimping dies, and store the tool in a clean, dry area.

**B. Periodic Inspection**

Regular inspections should be performed by quality control personnel. A record of scheduled inspections should remain with the tool and/or be supplied to supervisory personnel responsible for the tool. Though recommendations call for at least one inspection a month, the inspection frequency should be based on the amount of use, ambient working conditions, operator training and skill, and established company standards. These inspections should be performed in the following sequence:

### B-1. Visual Inspection

1. Remove all lubrication and accumulated film by immersing the tool (handles partially closed) in a suitable commercial degreaser that will not affect paint or plastic material.
2. Make certain all retaining pins are in place and secured with retaining rings. If replacements are necessary, refer to parts listed in Figure II-1.
3. Close the tool handles until the ratchet releases, then allow handles to open freely. If they do not open quickly and fully, the spring is defective and must be replaced (see Paragraph II-2, REPAIR).
4. Inspect the head assembly, with special emphasis on checking for worn, cracked, or broken dies. If damage to any part of the head assembly is evident, return the tool to AMP for evaluation and repair (see Paragraph II-2, REPAIR).

### B-2. Crimp Height Inspection

This inspection requires the use of a micrometer with a modified anvil as shown in Figure II-2. We recommend the modified micrometer (Crimp Height Comparator RS-1019-5L), which can be purchased from:

York Machinery & Supply Co.      VALCO  
20 North Penn Street      or      1410 Stonewood Drive  
York, PA 17401-1014      Bethlehem, PA 18017-3527

To inspect the terminal, proceed as follows:

1. Refer to the chart in Figure I-2, and select a terminal and a wire (maximum size) for each crimp section listed in the chart.
2. Refer to Paragraph I-3, CRIMPING PROCEDURE, and crimp the terminal(s) accordingly.
3. Using a crimp height comparator, measure wire barrel crimp height as shown in Figure II-2. If the crimp height conforms to that shown in the chart, the tool is considered dimensionally correct. If not, return the tool to AMP for evaluation and repair (see Paragraph II-2, REPAIR).

For additional information concerning the use of the crimp height comparator, refer to AMP Instruction Sheet IS 7424.

### B-3. CERTI-CRIMP Ratchet Inspection

Obtain a .001-in. shim that is suitable for checking the clearance between the bottoming surfaces of the crimping dies.

Proceed as follows:

1. Select a terminal, wire (maximum size), and the designated crimp section for the wire you are using (see Figure I-2).

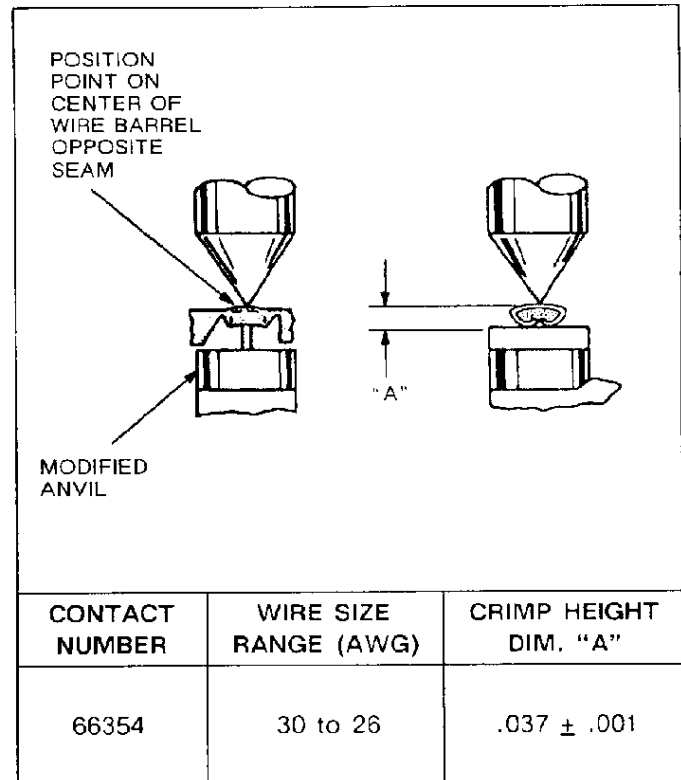

Fig. II-2

2. Position the terminal and wire between the crimping dies according to Paragraph I-3, CRIMPING PROCEDURE (Steps 1 through 6). Holding the wire in place, squeeze the tool handles together until the CERTI-CRIMP ratchet releases. Hold the tool handles in this position, maintaining just enough pressure to keep the dies closed.
3. Check the clearance between the bottoming surfaces of the crimping dies. If the clearance is .001 in. or less, the ratchet is satisfactory. If clearance exceeds .001, the ratchet is out of adjustment and must be repaired (see Paragraph II-2, REPAIR).

If the tool conforms to these inspection procedures, lubricate it with a THIN coat of any good SAE No. 20 motor oil and return it to service.

### II-2. REPAIR

Parts other than those specified in Figure II-1 must be replaced by AMP to ensure correct operation of the tool. When repair is necessary, return the tool with a written description of the problem to:

AMP Incorporated  
Customer Repair  
1523 North 4th Street  
Harrisburg, PA 17102-1604

or a wholly owned subsidiary of AMP Incorporated.