

PRODUCT NUMBER
75168-YXX-XXLF

INDICATES THE PRODUCT IS RoHS COMPLIANT
& COMPATIBLE, SEE NOTE 8
TOTAL NB OF POSITIONS 02 TO 36
PIN STYLE SEE SHEET 2

PLATING:

- 1 = 0.76µm FULL GOLD/GXT, OVER 1.27µm Ni MIN
- 3 = 3.81µm FULL TIN/LEAD OVER 1.27µm Ni MIN.
WHEN "LF" IS REQUIRED, 2µm MATTE TIN OVER
1.27µm MIN NICKEL IS PROVIDED INSTEAD OF TIN-LEAD
- 8 = 0.38µm FULL GOLD/GXT, OVER 1.27µm Ni MIN

NOTES:

1. HOUSING MAT'L : HIGH TEMPERATURE THERMOPLASTIC
FLAME RETARDANT PER UL94-V0, COLOR BLACK.
2. PIN MATERIAL : PHOSPHOR BRONZE.
3. DIM 1.27^{+0.03} FOR MOULDED SIDE(S)
ONLY. IF SIDE(S) ARE BROKEN, DIM 1.02
TO 1.7 MAX APPLIES.
4. PIN PUSH OUT FORCE : 12N MIN.
5. PRODUCT PACKAGED IN POLY BAGS.
6. TO DETERMINE DIMENSIONS :
N = NUMBER OF POSITIONS
EXAMPLE : 8 POS N x 2.54 = 20.32mm
7. FOR STANDARD SELECTIVE GOLD PLATED
PRODUCTS, SEE DRAWING 77315.
8. RoHS COMPATIBLE PRODUCT SPECIFICATIONS
 - a - SUFFIX "LF" IS ADDED JUST FOR EASY
LEADFREE IDENTIFICATION FOR PLATING VERSION 1 & 8.
 - b - MANUFACTURING PROCESS COMPATIBILITY
 - THE HOUSING WILL WITHSTAND EXPOSURE TO
260°C ±5°C SOLDER BATH TEMPERATURE FOR
5 SECONDS IN A WAVE SOLDER APPLICATION
WITH A 1.6mm MIN THICK CIRCUIT BOARD.
 - c - LABELING:
 - MEETS PACKAGING SPECS AS PER GS-14-920
 - d - LEGAL STATEMENT: SEE GS-22-008

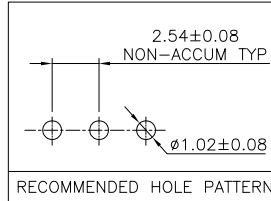
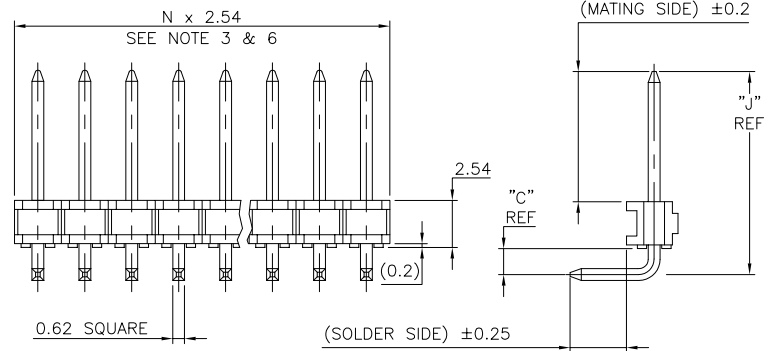
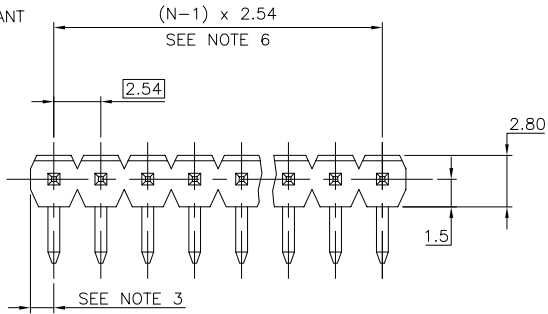

mat'l. code	surface	tolerance	projection	product family
SEE NOTE 1	ISO 1302	ISO 1006	ISO 1101	BSTIK
ltr	ecn no	dr	date	tolerances unless otherwise specified
AG	F06-0196	LMU	06.06.20	linear
AH	F08-0148	JCO	08.05.27	xxx ±0.05
AC	F10167	LMU	01.03.12	MULIN L
AD	F20116	DLE	02.01.15	enrg JMC
AE	F20149	DLE	02.02.19	chr
AF	F05-0186	LMU	05.05.02	appd JMC
sheet index	revision	AH	AE	
	sheet	1	2	

title	product family	dwg no	sheet 1 of 2	size
HEADER,SR,RA, POL,2.54mm	BSTIK	75168		A3
type	CUSTOMER	Drawing		

APPLICATION SPECIFIC					
PIN	STYLE	MATING	SOLDER	"C"	"J"
01		5.72	2.57	1.4	9.65
02		5.72	5.11	1.4	9.65
03		5.72	7.65	1.4	9.65
04		5.72	10.19	1.4	9.65
05		5.72	12.73	1.4	9.65
07		5.72	5.11	3.94	12.19
08		5.72	7.65	3.94	12.19
09		5.72	10.19	3.94	12.19
10		5.72	12.73	3.94	12.19
11		5.72	15.27	3.94	12.19
13		5.72	3.45	1.4	9.65
14		5.72	5.99	3.94	12.19
15		5.72	8.53	6.48	14.73
16		8.51	3	1.4	12.45
17		8.51	5.54	3.94	14.99
19		5.72	3.05	1.4	9.66
20		5.84	2.29	1.4	9.78
21		5.72	11.07	9.02	17.27
22		11.71	3.2	1.4	15.65
23		3	2.94	1.94	7.44
24		4.8	6.16	1.94	9.28
27		3.55	3.3	1.4	7.49
28		10	3.2	1.4	13.94

mat'l. code	SEE SHEET 1	surface	ISO 1302	tolerance	ISO 406	ISO 1101	projection	product family	BSTIK
ltr	ecr no	dr	date	tolerances unless otherwise specified			mm	title	HEADER,SR,RA, POL,2.54mm
Y	F40199	JMC	94.03.11	angles	linear		scale	dwg no	sheet 2 of -
AA	F90191	LMU	99.03.29					75168	size
AB	F00196	LMU	00.04.19						A3
AC	F10167	LMU	01.03.12	dr	MULIN L	99.03.29		type	CUSTOMER Drawing
AD	F20116	DLE	02.01.15	enrg	JMC	99.03.29			
AE	F06-0196	LMU	06.06.20	chr					
				appd	JMC	99.03.29			
sheet index	revision sheet								

form: A3