

Tous droits strictement réservés. Reproduction ou communication à des tiers  
Interdite sous quelque forme que ce soit sans autorisation écrite du propriétaire.  
Propriété de FCI. Droits de reproduction FCI.

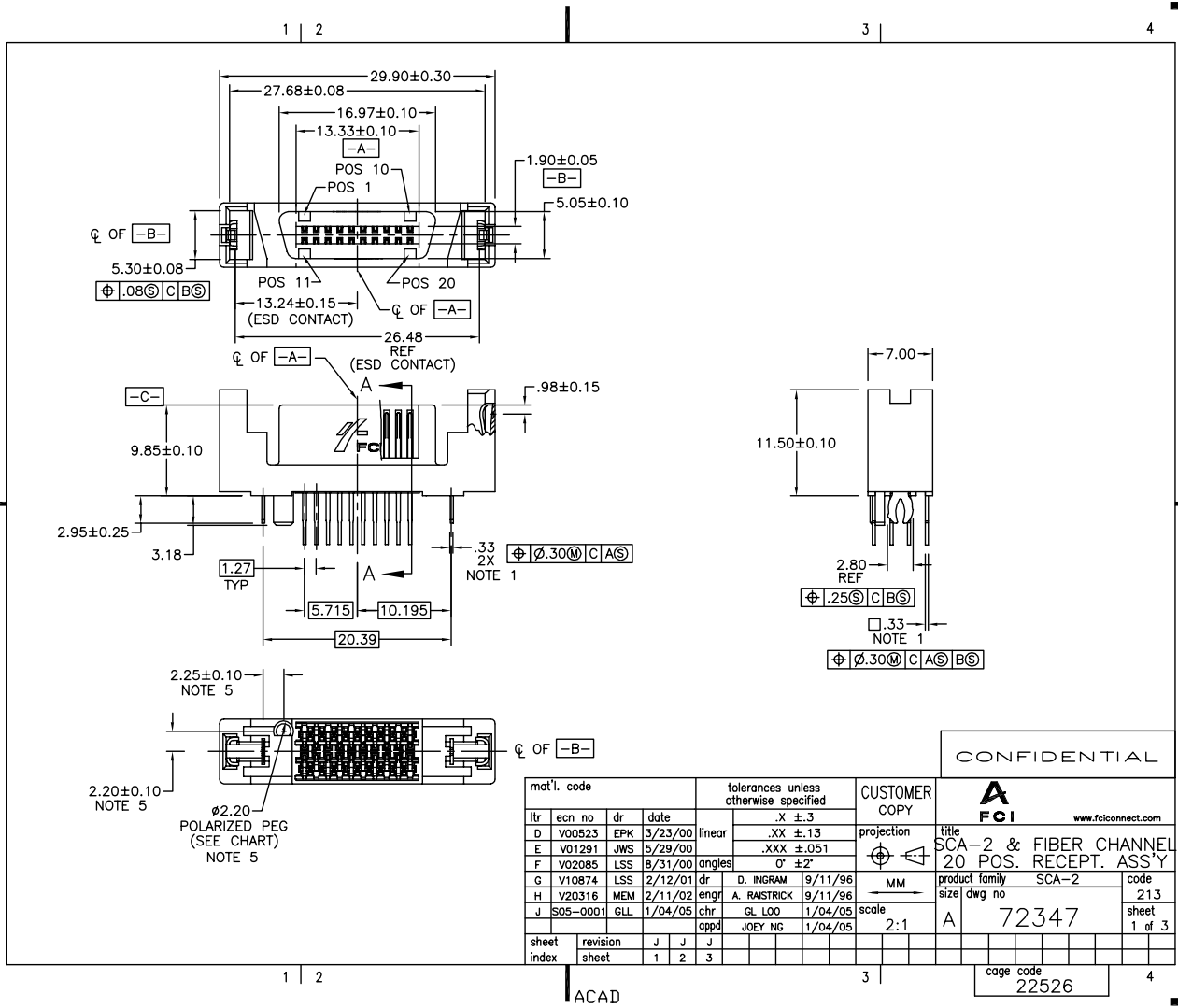

All rights strictly reserved. Reproduction or issue to third parties in any  
form whatever is not permitted without written authority from the proprietor.  
Property of FCI. Copyright FCI.



CONFIDENTIAL

mat'l. code		tolerances unless otherwise specified		CUSTOMER COPY	www.fciconnect.com		
itr	ecn no	dr	date	linear	projection	title	
D	V00523	EPK	3/23/00	.X ±.3		SCA-2 & FIBER CHANNEL 20 POS. RECEPT. ASS'Y	
E	V01291	JWS	5/29/00	.XX ±.13			
F	V02085	LSS	8/31/00	.XXX ±.051			
G	V10874	LSS	2/12/01	angles	0° ±2'	product family	
H	V20316	MEM	2/11/02	dr	D. INGRAM	9/11/96	code
J	S05-0001	GLL	1/04/05	chr	A. RAISTRICK	9/11/96	213
		appd	JOEY NG	1/04/05	scale	2:1	sheet
sheet index	revision sheet	J	J	J			1 of 3
		1	2	3			
					cage code	22526	

ACAD

Tous droits strictement réservés. Reproduction ou communication e des tiers  
 Interdite sous quelque forme que ce soit sans autorisation écrite du propriétaire.  
 Propriete de c FCI. Droits de reproduction FCI.



All rights strictly reserved. Reproduction or issue to third parties in any  
 form whatever is not permitted without written authority from the proprietor.  
 Property of FCI. Copyright FCI.

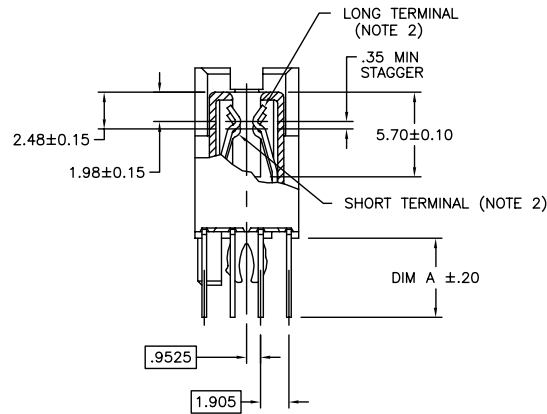

SECTION A-A

CONFIDENTIAL

mat'l. code		tolerances unless otherwise specified		CUSTOMER COPY		www.fciconnect.com	
ltr	ecn no	dr	date	linear	projection	title	
j				.X ±.3		SCA-2 & FIBER CHANNEL	
				.XX ±.13		20 POS. RECEPT. ASS'Y	
				.XXX ±.051		product family	code
				angles	0° ±2'	SCA-2	213
				dr	D. INGRAM	9/11/96	
				engr	A. RAISTRICK	9/11/96	
				chr	GL LOO	1/04/05	
				appd	JOEY NG	1/04/05	
sheet index	revision sheet				scale	2:1	
					size	A	
					dwg no	72347	
					sheet	2 of 3	

ACAD

cage code  
22526

PDM: Rev:J

STATUS: Released

Printed: May 26, 2010

Tous droits strictement réservés. Reproduction ou communication à des tiers  
 Interdite sous quelque forme que ce soit sans autorisation écrite du propriétaire.  
 Property of FCI. Droits de reproduction FCI.

FCI

All rights strictly reserved. Reproduction or issue to third parties in any  
 form whatever is not permitted without written authority from the proprietor.  
 Property of FCI. Copyright FCI.

PRODUCT NUMBER	"A" DIM	POLARIZATION PEG	PLATING	RECOMMENDED P.C. BOARD THICKNESS	PRODUCT NUMBER	PLATING	PRODUCT NUMBER	PLATING	PRODUCT NUMBER	PLATING
72347-001	2.79	YES	NOTE ④	1.57mm (0.062")	72347-101	NOTE ⑥	72347-001LF	NOTE ⑧	72347-101LF	NOTE ⑦
72347-002	2.79	NO			72347-102		72347-002LF		72347-102LF	
72347-003	3.18	YES		72347-103	72347-003LF		72347-103LF			
72347-004	3.18	NO		72347-104	72347-004LF		72347-104LF			
72347-005	4.06	YES		72347-105	72347-005LF		72347-105LF			
72347-006	4.06	NO		72347-106	72347-006LF		72347-106LF			

NOTES :

- ① TRUE POSITION NOTES APPLY AT TERMINAL TIP.
- ② CONTACTS IN POSITIONS 1 THRU 10 & 16 ARE SHORT TERMINALS. CONTACTS IN POSITIONS 11, 12, 13, 14, AND 17, 18, 19, 20 ARE LONG TERMINALS.
3. RAW MATERIALS:  
 HOUSING: HTN, UL94V-0, COLOR: BLACK  
 CONTACTS: PHOSPHOR-BRONZE
- ④ CONTACT PLATING: 30u" (0.76um) MIN. GXT PLATING OVER 50u" (1.27um) NICKEL MIN. UNDERPLATE IN CONTACT AREA. 100u" (2.54um) MIN. TIN-LEAD PLATING OVER 50u" (1.27um) MIN. NICKEL UNDERPLATE IN P.C. BOARD LEG AREA. 50u" (1.27um) MIN. NICKEL UNDERPLATE OVER REMAINING AREA.
- ⑤ DIMENSIONS DO NOT APPLY TO CONNECTOR STYLES WITHOUT POLARIZATION PEG. (SEE CHART)
- ⑥ CONTACT PLATING: 30u" (0.76um) MIN. GOLD PLATING OVER 50u" (1.27um) NICKEL MIN. UNDERPLATE IN CONTACT AREA. 100u" (2.54um) MIN. TIN-LEAD PLATING OVER 50u" (1.27um) MIN. NICKEL UNDERPLATE IN P.C. BOARD LEG AREA. 50u" (1.27um) MIN. NICKEL UNDERPLATE OVER REMAINING AREA.
- ⑦ CONTACT PLATING: 30u" (0.76um) GOLD PLATING OVER 50u" (1.27um) NICKEL UNDERPLATE IN CONTACT AREA. 100u" (2.54um) - 200u" (5.08um) TIN PLATING OVER 50u" (1.27um) - 100u" (2.54um) NICKEL UNDERPLATE IN P.C. BOARD LEG AREA. 50u" (1.27um) NICKEL UNDERPLATE OVER REMAINING AREA.
- ⑧ CONTACT PLATING: 30u" (0.76um) GXT PLATING OVER 50u" (1.27um) NICKEL UNDERPLATE IN CONTACT AREA. 100u" (2.54um) - 200u" (5.08um) TIN PLATING OVER 50u" (1.27um) - 100u" (2.54um) NICKEL UNDERPLATE IN P.C. BOARD LEG AREA. 50u" (1.27um) NICKEL UNDERPLATE OVER REMAINING AREA.
- ⑨ THE HOUSING WILL WITHSTAND EXPOSURE TO 260°C PEAK TEMPERATURE FOR 10 SECONDS IN A WAVE SOLDER APPLICATION WITH A 1.57MM THICK CIRCUIT BOARD.
- ⑩ THIS PRODUCT MEETS EUROPEAN UNION DIRECTIVES AND OTHER COUNTRY REGULATIONS AS DESCRIBED IN GS-22-008.

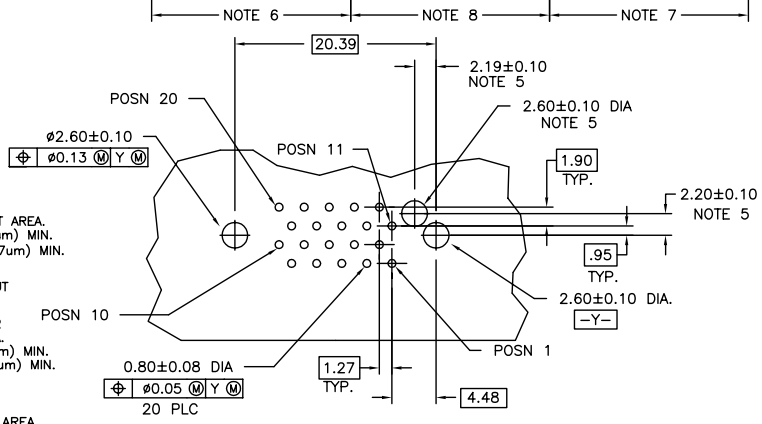

RECOMMENDED PC BOARD MOUNTING DIMENSIONS COMPONENT SIDE

CONFIDENTIAL

mat'l. code				tolerances unless otherwise specified		CUSTOMER COPY		FCI		www.fciconnect.com	
ltr	ecn no	dr	date	linear	.X ±.3	projection	title	product family	code	size	dwg no
j				angles	.XX ±.13	MM	SCA-2& FIBER CHANNEL	SCA-2	213	A	72347
				dr	.XXX ±.051	scale	20 POS. RECEPT. ASS'Y		3 of 3		
				enrg	0 ±.2	2:1					
				chr	D. INGRAM 9/11/96						
				appd	A. RAISTRICK 9/11/96						
					GL LOO 1/04/05						
					JOEY NG 1/04/05						
sheet index	revision sheet										

1 | 2

3

4

ACAD

cage code 22526

PDM: Rev:J

STATUS: Released

Printed: May 26, 2010