

PRODUCT NUMBER

6 4 9 9 2 - X X X - X X X X L F

PLATING
NOTE 12
S= 15µ [0.38µm] GOLD/GXT
ON CONTACT AREA
100µ [2.54µm] PURE TIN
ON TAIL
G= 30µ [0.76µm] GOLD/GXT
ON CONTACT AREA
100µ [2.54µm] PURE TIN
ON TAIL

LEAD FREE OPTION
NOTE 9.11

RETENTION
R= RETENTION LEG
NOTE 6

POLARIZATION
NOTE 8

TAIL LENGTH
5= .125/3.18

POSITIONS PER ROW
13 POS.

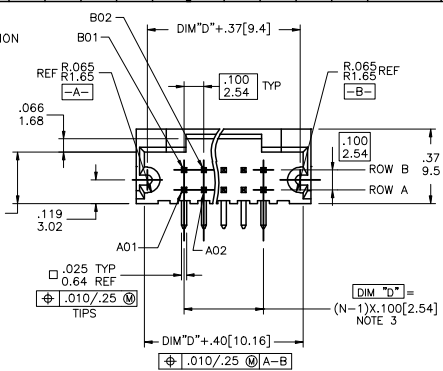

- NOTES:
- HOUSING MAT'L: HIGH TEMPERATURE THERMOPLASTIC. UL94V-0
COLOR: BLACK
 - PIN MATERIAL: PHOSPHOR-BRONZE
 - TO DETERMINE DIMENSIONS:
N= NUMBER OF POSITIONS PER ROW.
EXAMPLE: 13 POS., (N-1)x.100/2.54=1.200/30.48
 - 3LBS./1.36 KG MIN. RETENTION IN EITHER DIRECTION.
 - PACKAGED IN TRAYS.
 - RETENTION LEG:
5LB/2.3KG MAX INSERTION FORCE AND .25LB/1KG MIN RETENTION FORCE
PER RETENTIVE PIN USING .062/1.57 THICK CIRCUIT BOARD AND RECOMMENDED
HOLE PATTERN. RETENTIVE LOCATION AT THE DISCRETION OF THE MANUFACTURER.
RETENTION IS TWO PINS PER PART ADJACENT TO ONE ANOTHER.
IF FEATURE IS NOT APPLICABLE, REMOVE FROM PRODUCT NUMBER.
 - UNDER PLATING: .050µ"/1.2µm Ni.
 - FOR POLARIZATION SPECIFY POSITION NUMBER (i.e., A03=ROW A POS. 3)
TO OMIT PIN.
IF FEATURE IS NOT APPLICABLE, REMOVE FROM PRODUCT NUMBER.
 - ADD "LF" SUFFIX AT THE END OF PART NUMBER FOR LEAD FREE
OPTION.
 - THE HOUSING WILL WITHSTAND EXPOSURE TO 260°C PEAK TEMPERATURE
FOR 15 SECONDS IN A WAVE SOLDER APPLICATION WITH A 1.5mm
MINIMUM THICK CIRCUIT BOARD. SEE APPLICATION NOTES/PROCEDURES
IF THEY ARE AVAILABLE.
 - THIS PRODUCT MEETS EUROPEAN UNION DIRECTIVES AND OTHER
COUNTRY REGULATION AS DESCRIBED IN GS-22-008.
 - PLATING OPTIONS:
MAY BE EITHER GOLD OR GXT PLATED AT MANUFACTURER'S OPTION.

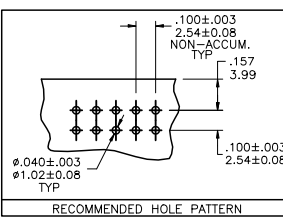
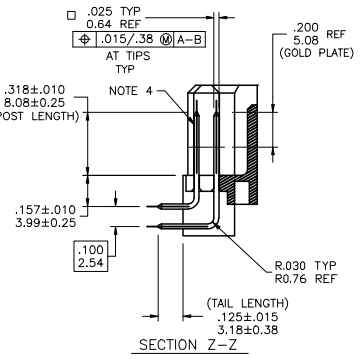
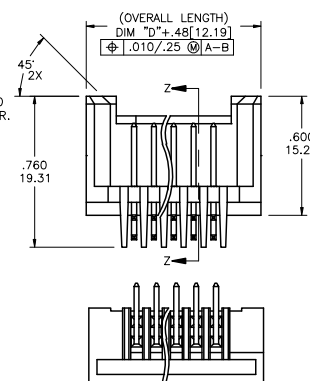

mal't. code		surface	tolerance	projection	product family
		ISO 1302	ISO 46 ISO 1001		HEADER
lfr	ecr no	dr	date	tolerances unless otherwise specified	
C	M05-0220	MHT	10/20/05	linear	XX±.01/XX±.03
D	M07-0116	AGS	2/19/07	linear	XXX±.005/XXX±.013
E	M07-0246	MHT	5/30/07	0'±2'	XXXX±.0020/XXXX±.0050
F	M09-0099	MHT	4/16/09	dr	O. INGRAM 6/23/99
G	M09-0099	MHT	7/06/09	engr	H. SUNDY 7/12/99
H	M09-0136	MHT	9/03/09	chr	H. SUNDY 7/12/99
J	M09-0154	MHT	9/10/09	appd	H. SUNDY 7/12/99
sheet	revision	J			
index	sheet	1			

title	product family
.100/2.54mm GUIDE PIN SHROUDED R/A HEADER	HEADER
dwg no	sheet 1 of 1 size
64992	A3
type	Product Customer Drawing