

REV. NO.		REV. DATE		REV. DESCRIPTION	
54	B	REV PER EC	0038-0018-99		

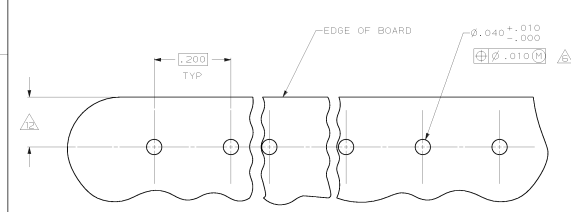
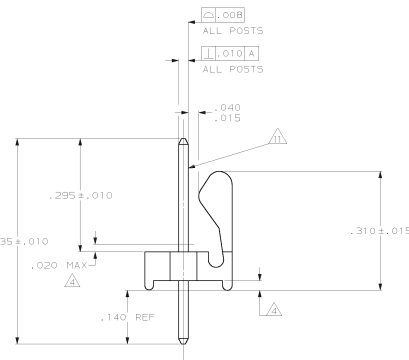
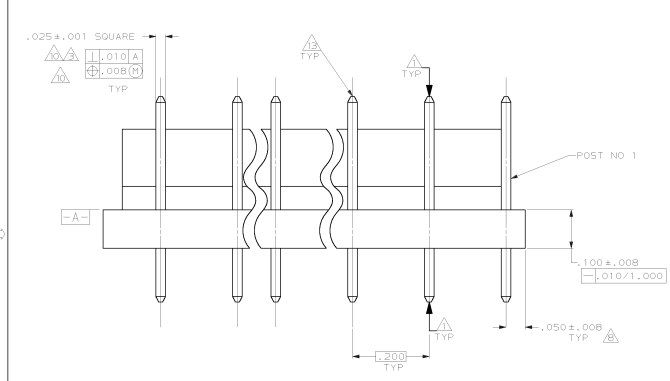
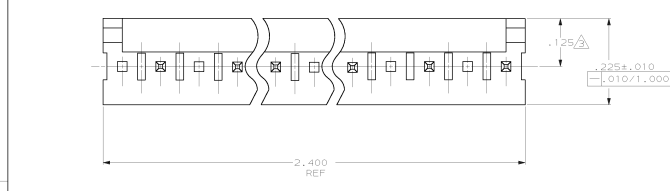

RECOMMENDED MOUNTING HOLE PATTERN FOR .063 THICK P.C. BOARD

- △ POST TO WITHSTAND 13 NEWTONS (3LBS.) MIN. AXIAL FORCE IN BOTH DIRECTIONS SHOWN WITHOUT DISLODGING.
- △ TOLERANCES APPLY TO SOLDER SIDE OF BOARD.
- △ MEASURED AT SURFACE $\overline{A-A}$
- △ PLASTIC FLASH PERMITTED IN THIS AREA.
- 5. PARTS COMPLY WITH AMP SOLDERABILITY SPEC. NO. 105-11-2.
- △ ONE HOLE MAY BE UNDERSIZED (.035/.032 DIA.) FOR ASSEMBLY RETENTION DURING WAVE SOLDERING.
- △ MATERIAL: HEADER-THERMOPLASTIC POLYESTER 94V-0(NATURAL) POST-COPPER ALLOY (TIN PLATED)
- △ COORDINATE DIMENSION APPLIES FROM CENTER OF ACTUAL FEATURE.
- 9. PLASTIC BURRS CAUSED BY CUT-OFF TOOLING ARE PERMITTED WITHIN THE MAXIMUM TOLERANCE ENVELOPE.
- △ POST TO BE MEASURED WHEN STRIP IS HELD FLAT.
- △ POST MUST WITHSTAND TWO 90° BENDS AGAINST EXTRUSION WITHOUT BREAKING.
- △ DIMENSION SHOULD BE .130 MIN WHEN MATING WITH A MTA 100 CONNECTOR ASSEMBLY OR WHEN MATING WITH A CST 100 CONNECTOR.
- △ PIN BURR OF .005 MAX VERTICAL AND .003 MAX HORIZONTAL PERMITTED AT POST TIPS ON BOTH ENDS.

644692-1 SHOWN

IN	MM	IN	MM
.063	1.60	-	-
.050	1.27	-	-
.040	1.02	2.400	60.96
.035	0.89	1.000	25.40
.032	0.81	.535	13.58
.025	0.64	.310	7.87
.020	0.51	.295	7.49
.015	0.38	.225	5.72
.010	0.25	.200	5.08
.008	0.20	.140	3.56
.005	0.13	.130	3.30
.003	0.08	.125	3.18
.001	0.03	.100	2.54



CONVERSION TABLE

DO NOT SCALE PRINT. UNLESS SPECIFIED DIMENSIONS IN MM (INCHES) TOLERANCES IN IN		DR 1-11-99 B. LEWIS	
2 PLE DEC # .005	3 PLE DEC # 0.001	AMP	AMP Incorporated Harrisburg, PA 17105-3608
MATERIAL	PRODUCT SPEC	NAME	MTA 100 HEADER ASSEMBLY, FRICTION LOCK, NOTCHED, .025 SQUARE STRAIGHT POST, TIN PLATED, 24 POSITION, OMITTED POST
FINISH	APPLICATION SPEC	SIZE	00779
DRYING		SCALE	B:1
		DRAWING NO	644692
		SHEET	1 OF 1

CUSTOMER DRAWING