

PRODUCT NUMBER	PLATING PERFORMANCE LEVEL	FOR REAR PLUG-UP APPLICATIONS USE SHROUD
63784-1YYY	TELCORDIA CO	74993-102
63784-1YYLFF	TELCORDIA CO	84625-102LFF
63784-5YYY	TELCORDIA UE	74993-502
63784-5YYLFF	TELCORDIA UE	84625-502LFF
63784-9YYY	TELCORDIA CO	74993-102
63784-9YYLFF	TELCORDIA CO	84625-102LFF
63784-AYYY	CUSTOMER SPECIAL	74993-102
63784-AYYLFF	CUSTOMER SPECIAL	84625-102LFF

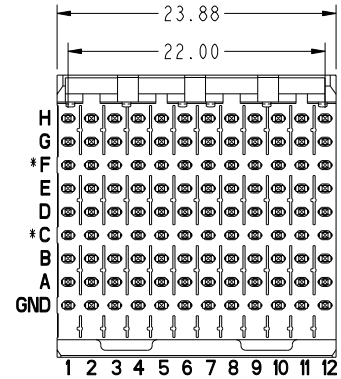

mat'l code SEE NOTE 5				tolerances unless otherwise specified				CUSTOMER		FCJ	
lfr	ecm no.	dr	date	linear	0.X ±0.3	projection	COPY		www.fcjconnect.com		
AH	V06-0498	DCH	2006-05-30		0.XX ±0.13		title		VERTICAL SIGNAL HDR 8 ROW		
AJ	V07-0169	DCH	2007-03-27		.XXX ±.051		P.F.		96 POS. SELECT LOAD EXT.		
AK	V08-0016	HTB	2008-01-10	angles	0° ±2°		product family		METRAL 1000		
AL	V08-0051	LP	2008-02-19	dr	E. KROPER. 2001-01-10		size		dwg no		
-	-	-	-	engr	J. VOLSTORF 2001-01-10		scale		213		
AF	V05-1022	LP	2005-11-08	chr	J. VOLSTORF 2001-01-10		sheet		1 of 10		
AG	V05-1125	LP	2005-12-19	oppd	J. VOLSTORF 2001-01-10		code		63784		
sheet index	revision sheet	AL	AL	AL	AL	AL	AL	AL	AL	AL	
		1	2	3	4	5	6	7	8	9	

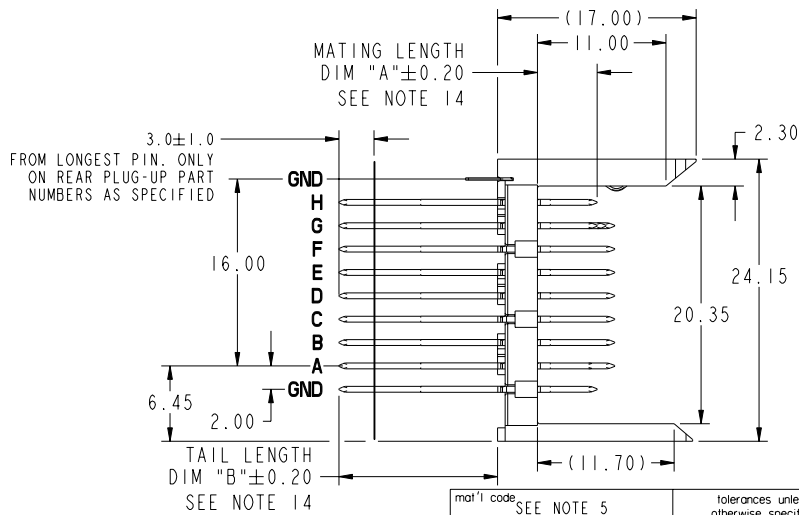
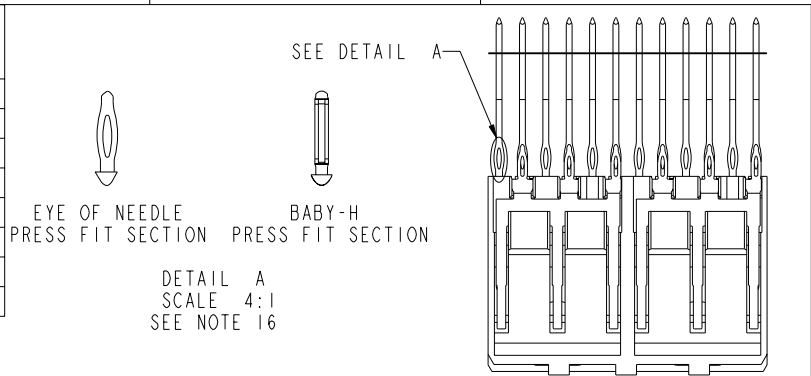

This document is the property of and embodies CONFIDENTIAL and PROPRIETARY information of FCJ. No part of the information shown on this document may be used in any way or disclosed to others without the written consent of FCJ. Copyright FCJ.

REV E - 2006-04-18

PDM: Rev:AL STATUS:Released Printed: Dec 17, 2009



This document is the property of and embodies CONFIDENTIAL and PROPRIETARY information of FCI. No part of the information shown on this document may be used in any way or disclosed to others without the written consent of FCI. Copyright FCI.

PIN NO.	DIM A MATING LENGTH	DIM B TAIL LENGTH	PCB THICKNESS RANGE ACCOMMODATED BY PIN'S TAIL LENGTH				
			WHEN MATING TO A 74981 SERIES RECEPTACLE		WHEN MATING TO A 52066 SERIES METRAL 4000 RECEPTACLE		
			ROWS A, B, C, D, E, F, G & H	GROUND ROW	ROWS A, B, D, E, G & H	ROW C & F	GROUND ROW
01*	5.00	4.30	1.60 MIN	1.60 MIN	1.60 MIN	1.60 MIN	1.60 MIN
22		12.20	2.95 - 3.80	2.95 - 4.20	2.95 - 3.80	2.95 - 3.80	2.95 - 4.20
30		12.95	2.95 - 4.55	3.25 - 4.95	2.95 - 4.55	2.95 - 4.55	3.25 - 4.95
05		13.70	2.95 - 5.30	4.00 - 5.70	3.30 - 5.30	2.95 - 5.30	4.00 - 5.70
35		14.45	3.05 - 6.05	4.75 - 6.45	4.05 - 6.05	3.05 - 6.05	4.75 - 6.45
48		15.20	3.80 - 6.80	5.50 - 7.20	4.80 - 6.80	3.80 - 6.80	5.50 - 7.20
40		15.70	4.30 - 7.30	6.00 - 7.70	5.30 - 7.30	4.30 - 7.30	6.00 - 7.70
65		16.40	5.00 - 8.00	6.70 - 8.40	6.00 - 8.00	5.00 - 8.00	6.70 - 8.40
09		17.10	5.70 - 8.70	7.40 - 9.10	6.70 - 8.70	5.70 - 8.70	7.40 - 9.10
02*		5.75	4.30	1.60 MIN	1.60 MIN	1.60 MIN	1.60 MIN
44	12.20		2.95 - 3.80	2.95 - 4.20	2.95 - 3.80	2.95 - 3.80	2.95 - 4.20
31	12.95		2.95 - 4.55	3.25 - 4.95	2.95 - 4.55	2.95 - 4.55	3.25 - 4.95
06	13.70		2.95 - 5.30	4.00 - 5.70	3.30 - 5.30	2.95 - 5.30	4.00 - 5.70
36	14.45		3.05 - 6.05	4.75 - 6.45	4.05 - 6.05	3.05 - 6.05	4.75 - 6.45
49	15.20		3.80 - 6.80	5.50 - 7.20	4.80 - 6.80	3.80 - 6.80	5.50 - 7.20
25	15.70		4.30 - 7.30	6.00 - 7.70	5.30 - 7.30	4.30 - 7.30	6.00 - 7.70
66	16.40		5.00 - 8.00	6.70 - 8.40	6.00 - 8.00	5.00 - 8.00	6.70 - 8.40
10	17.10		5.70 - 8.70	7.40 - 9.10	6.70 - 8.70	5.70 - 8.70	7.40 - 9.10
03*	6.50		4.30	1.60 MIN	1.60 MIN	1.60 MIN	1.60 MIN
45		12.20	2.95 - 3.80	2.95 - 4.20	2.95 - 3.80	2.95 - 3.80	2.95 - 4.20
32		12.95	2.95 - 4.55	3.25 - 4.95	2.95 - 4.55	2.95 - 4.55	3.25 - 4.95
07		13.70	2.95 - 5.30	4.00 - 5.70	3.30 - 5.30	2.95 - 5.30	4.00 - 5.70
37		14.45	3.05 - 6.05	4.75 - 6.45	4.05 - 6.05	3.05 - 6.05	4.75 - 6.45
50		15.20	3.80 - 6.80	5.50 - 7.20	4.80 - 6.80	3.80 - 6.80	5.50 - 7.20
41		15.70	4.30 - 7.30	6.00 - 7.70	5.30 - 7.30	4.30 - 7.30	6.00 - 7.70
24		16.40	5.00 - 8.00	6.70 - 8.40	6.00 - 8.00	5.00 - 8.00	6.70 - 8.40
11		17.10	5.70 - 8.70	7.40 - 9.10	6.70 - 8.70	5.70 - 8.70	7.40 - 9.10

mat'l code: SEE NOTE 5		tolerances unless otherwise specified		CUSTOMER	www.fciconnect.com
lfr	ecm no.	dr	date	COPY	
AL				projection	title VERTICAL SIGNAL HDR 8 ROW P.F. 96 POS. SELECT LOAD EXT.
				$0.X \pm 0.3$ $0.XX \pm 0.13$ $.XXX \pm .051$ angles $0^\circ \pm 2^\circ$	
					product family METRAL 1000 code size dwg no 213 sheet 2
				dr E. KROPER. 2001-01-10 engr J. VOLSTORF 2001-01-10 chr J. VOLSTORF 2001-01-10 oppd J. VOLSTORF 2001-01-10	
sheet index	revision sheet			scale 1:1	63784

REV E - 2004-04-18

PDM: Rev:AL STATUS:Released Printed: Dec 17, 2009



This document is the property of and embodies CONFIDENTIAL and PROPRIETARY information of FCJ. No part of the information shown on this document may be used in any way or disclosed to others without the written consent of FCJ. Copyright FCJ.

PIN NO.	DIM A MATING LENGTH	DIM B TAIL LENGTH	PCB THICKNESS RANGE ACCOMMODATED BY PIN LENGTH				
			WHEN MATING TO A 74981 SERIES RECEPTACLE		WHEN MATING TO A 52066 SERIES METRAL 4000 RECEPTACLE		
			ROWS A,B,C, D,E,F,G & H	GROUND ROW	ROWS A,B, D,E,G & H	ROW C & F	GROUND ROW
04*	7.25	4.30	1.60 MIN	1.60 MIN	1.60 MIN	1.60 MIN	1.60 MIN
46		12.20	2.95 - 3.80	2.95 - 4.20	2.95 - 3.80	2.95 - 3.80	2.95 - 4.20
33		12.95	2.95 - 4.55	3.25 - 4.95	2.95 - 4.55	2.95 - 4.55	3.25 - 4.95
08		13.70	2.95 - 5.30	4.00 - 5.70	3.30 - 5.30	2.95 - 5.30	4.00 - 5.70
38		14.45	3.05 - 6.05	4.75 - 6.45	4.05 - 6.05	3.05 - 6.05	4.75 - 6.45
51		15.20	3.80 - 6.80	5.50 - 7.20	4.80 - 6.80	3.80 - 6.80	5.50 - 7.20
42		15.70	4.30 - 7.30	6.00 - 7.70	5.30 - 7.30	4.30 - 7.30	6.00 - 7.70
67		16.40	5.00 - 8.00	6.70 - 8.40	6.00 - 8.00	5.00 - 8.00	6.70 - 8.40
12		17.10	5.70 - 8.70	7.40 - 9.10	6.70 - 8.70	5.70 - 8.70	7.40 - 9.10
19*		8.00	4.30	1.60 MIN	1.60 MIN	1.60 MIN	1.60 MIN
47	12.20		2.95 - 3.80	2.95 - 4.20	2.95 - 3.80	2.95 - 3.80	2.95 - 4.20
34	12.95		2.95 - 4.55	3.25 - 4.95	2.95 - 4.55	2.95 - 4.55	3.25 - 4.95
20	13.70		2.95 - 5.30	4.00 - 5.70	3.30 - 5.30	2.95 - 5.30	4.00 - 5.70
39	14.45		3.05 - 6.05	4.75 - 6.45	4.05 - 6.05	3.05 - 6.05	4.75 - 6.45
52	15.20		3.80 - 6.80	5.50 - 7.20	4.80 - 6.80	3.80 - 6.80	5.50 - 7.20
43	15.70		4.30 - 7.30	6.00 - 7.70	5.30 - 7.30	4.30 - 7.30	6.00 - 7.70
68	16.40		5.00 - 8.00	6.70 - 8.40	6.00 - 8.00	5.00 - 8.00	6.70 - 8.40
21	17.10		5.70 - 8.70	7.40 - 9.10	6.70 - 8.70	5.70 - 8.70	7.40 - 9.10

- \* STUB PINS - NO REAR PLUG-UP
- \*\* THE GREATEST RANGE OCCURS WHEN THE B DIMENSION OF PIN 'GND' IS ONE SIZE SHORTER THEN THE OTHER PINS.

mat'l code		SEE NOTE 5		tolerances unless otherwise specified		CUSTOMER		FCJ		www.fcjconnect.com	
lfr	ecm no.	dr	date	linear	0.X ±0.3	projection	COPY	title			
AL					.XX ±0.13			VERTICAL SIGNAL HDR 8 ROW			
				angles	.XXX ±.051			P.F. 96 POS. SELECT LOAD EXT.			
				dr	0° ±2°	scale		product family	METRAL 1000	code	213
				engr	E. KROPER. 2001-01-10	1:1		size	dwg no	63784	sheet
				chr	J. VOLSTORF 2001-01-10						3
				appd	J. VOLSTORF 2001-01-10						
sheet index	revision sheet										

REV E - 2004-04-18

PDM: Rev:AL STATUS:Released Printed: Dec 17, 2009

cage code 22526 4



This document is the property of and embodies  
 CONFIDENTIAL and PROPRIETARY information of FCJ.  
 No part of the information shown on this  
 document may be used in any way or disclosed  
 to others without the written consent of FCJ.  
 Copyright FCJ.

PRODUCT NUMBER  
SEE SHEET 1

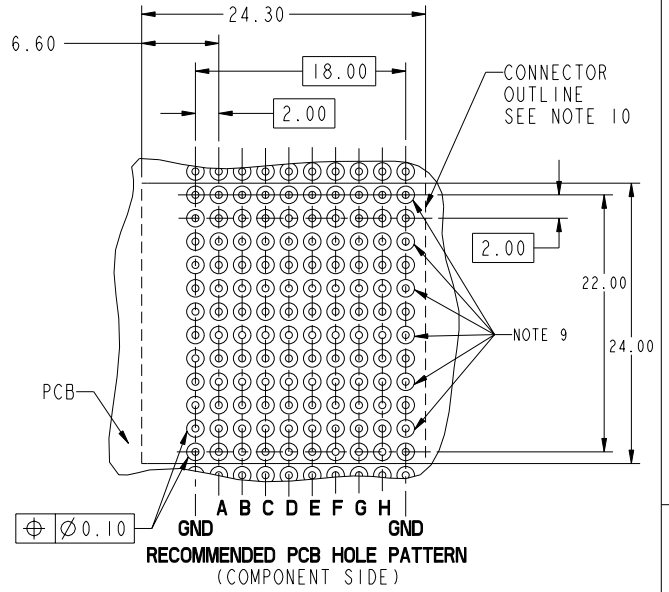
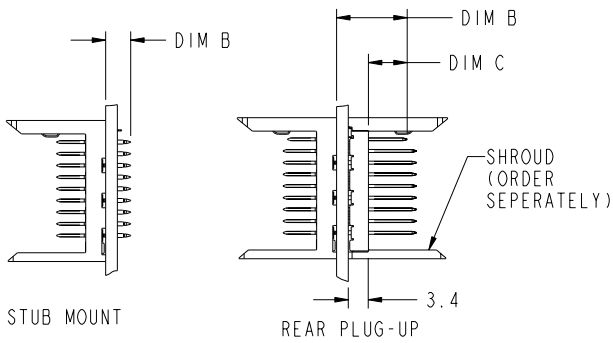

PRESS-FIT HOLES *	OPTION 1
HOLE DIAMETER AFTER PLATING	Ø 0.65-0.80
DRILLED HOLE	Ø 0.81-0.86 (Ø 0.85 DRILL)
COPPER PLATING	0.025 MIN
SnPb PLATING	0.005-0.015

\* SEE PRINT 58351 FOR ADDITIONAL PCB INFO.

mat'l code: SEE NOTE 5				tolerances unless otherwise specified		CUSTOMER		FCJ	
lfr	ecn no.	dr	date	linear	0.X ±0.3	projection	COPY	www.fcjconnect.com	
AL					0.XX ±0.13			title VERTICAL SIGNAL HDR 8 ROW	
				angles	.XXX ±.051			P.F. 96 POS. SELECT LOAD EXT.	
				dr	0° ±2°	MM		product family	METRAL 1000
				engr	E. KROPER. 2001-01-10	scale		size	dwg no
				chr	J. VOLSTORF 2001-01-10	1:1		A	63784
				oppd	J. VOLSTORF 2001-01-10				code
sheet index	revision sheet								213
									sheet 4
									code
									22526

REV E - 2004-04-18

PDM: Rev:AL

STATUS:Released

Printed: Dec 17, 2009

PRODUCT NUMBER  
SEE SHEET 1

NOTES:

- 1. SEE APPLICATION SPECIFICATION GS-20-010 FOR INFORMATION ON AVAILABLE TOOLING, CURCUIT BOARD DESIGN CONSIDERATIONS, REPAIR PROCEDURES AND PRODUCT OFFERINGS.
- 2. SEE FCI PUBLICATION 950511-028 FOR "ELECTRICAL PERFORMANCE DATA FOR DIFFERENTIAL APPLICATIONS."
- 3. SEE FCI PUBLICATION 950511-028 FOR "ELECTRICAL PERFORMANCE DATA FOR SINGLE-ENDED APPLICATION."
- 4. UNLESS OTHERWISE SPECIFIED, ALL DIMENSIONS AND TOLERANCES TOLERANCES ARE IN ACCORDANCE WITH ASME Y14.5M, 1994
- 5. HOUSING MATERIAL: LIQUID CRYSTAL POLYMER, 30% GLASS FILLED, FLAME RETARDANT PER UL 94-V0.  
PIN MATERIAL: PHOSPHER BRONZE  
GROUND SPRING MATERIAL: PHOSPHER BRONZE
- 6. PLATING INFORMATION: PLATING ON CONTACT AREA MEETS THE PERFORMANCE LEVELS SHOWN IN TABLE ON SHEET 1. PLATING ON "LF" TAILS IS Sn. PLATING ON ALL OTHER TAILS IS SnPb.
- 7. DIMENSIONAL RESTRICTIONS OF PINS IN HEADERS.  
FOR MATING WITH METRAL 1000 RECEPTACLES  
DIM A : 5.00mm MIN, 8.00mm MAX FOR ROWS A-H  
DIM A : 5.00mm MIN, 5.75mm MAX FOR ROW GND NEXT TO ROW A  
DIM C : 5.00mm MIN, 8.00mm MAX FOR ROWS A-H  
DIM C : 4.60mm MIN, 6.30mm MAX FOR ROW GND NEXT TO ROW A  
FOR MATING WITH METRAL 4000 RECEPTACLES  
DIM A : 5.00mm MIN, 6.50mm MAX FOR ROWS A, B, D, E, G & H  
DIM A : 5.00mm MIN, 8.00mm MAX FOR ROW C & F  
DIM A : 5.00mm MIN, 5.75mm MAX FOR ROW GND NEXT TO ROW A  
DIM C : 5.00mm MIN, 7.00mm MAX FOR ROWS A, B, D, E, G & H  
DIM C : 5.00mm MIN, 8.00mm MAX FOR ROW C & F  
DIM C : 4.60mm MIN, 6.30mm MAX FOR ROW GND NEXT TO ROW A
- 8. THE MIN PCB THICKNESS FOR REAR PLUG-UP APPLICATIONS IS 2.9mm SINCE THE COMPLIANT SECTIONS OF THE GROUND SPRING OF THE HEADER DIRECTLY OPPOSE THE GROUND SPRING OF THE SHROUD. THE MIN PCB THICKNESS FOR FRONT PLUG-UP ONLY APPLICATIONS IS 1.6mm.

- 9. THESE HOLES ARE NEEDED FOR REAR PLUG-UP DESIGNS USING A SHROUD AND MAY BE OMITTED FOR FRONT PLUG-UP ONLY DESIGNS.
- 10. THE 'CONNECTOR OUTLINE' IS THE MIN OUTLINE REQUIRED. TO DETERMINE THE OUTLINE NECESSARY TO PERMIT THE VARIOUS TYPES OF REPAIR OPERATIONS, SEE APPLICATION SPECIFICATION GS-20-010.
- 11. CURRENT RATING : 1 AMP PER PIN
- 12. TEMPERATURE RANGE : -55°C TO +105°C
- 13. P/N 63784-XXXXLF  
LEAD FREE (OPTIONAL)  
SELECT LOAD PATTERN  
PLATING CODE
- 14. AFTER INSERTION INTO CIRCUIT BOARD WITH QUALIFIED TOOL.
- 15. PRODUCTS WHERE THE PART NUMBER ENDS IN LF MEET EUROPEAN UNION DIRECTIVES AND OTHER COUNTRY REGULATIONS AS DESCRIBED IN GS-22-008.  
ALL PRODUCTS WILL WITHSTAND EXPOSURE TO 260°C FOR 60 SECONDS IN A CONVECTION, INFRA-RED OR VAPOR PHASE REFLOW OVEN.
- 16. PIN TYPE IS AT THE MANUFACTURERS OPTION AND CAN BE EITHER BABY-H OR EYE OF THE NEEDLE STYLE



This document is the property of and embodies CONFIDENTIAL and PROPRIETARY information of FCI. No part of the information shown on this document may be used in any way or disclosed to others without the written consent of FCI. Copyright FCI.

mat'l code SEE NOTE 5				tolerances unless otherwise specified		CUSTOMER		FCI www.fciconnect.com	
ltr	ecn no.	dr	date	linear	0.X ±0.3	COPY		title	
AL				angles	0.XX ±0.13	projection		VERTICAL SIGNAL HDR 8 ROW	
					.XXX ±.051	MM		P.F. 96 POS. SELECT LOAD EXT.	
				dr	0° ±2°	scale		product family METRAL 1000 code	
				eng		1:1		size	
				ctr	E. KROPER. 2001-01-10			dwg no	
				appd	J. VOLSTORF 2001-01-10			63784	
					J. VOLSTORF 2001-01-10			213	
sheet index	revision sheet							sheet 5	











This document is the property of and embodies CONFIDENTIAL and PROPRIETARY information of FCI. No part of the information shown on this document may be used in any way or disclosed to others without the written consent of FCI. Copyright FCI.

REV E - 2004-04-18

METRAL P/N	ROW	CONTACT CODE											
		1	2	3	4	5	6	7	8	9	10	11	12
63784-X028 RPU FOR LEAD FREE SEE NOTE 15	H	05	05	05	05	05	05	05	05	05	05	05	05
	G	05	05	05	05	05	05	05	05	05	05	05	05
	F	05	05	05	05	05	05	05	05	05	05	05	05
	E	05	05	05	05	05	05	05	05	05	05	05	05
	D	01	01	01	01	01	01	01	01	01	01	01	01
	C	01	01	01	01	01	01	01	01	01	01	01	01
	B	01	01	01	01	01	01	01	01	01	01	01	01
	A	01	01	01	01	01	01	01	01	01	01	01	01
	GND	01	01	01	01	01	01	01	01	01	01	01	01

FOR REAR PLUG UP APPLICATIONS, PCB THICKNESS RANGE: 2.95 -5.30 WHEN MATED TO METRAL 1000 RECEPT. AND 3.30-5.30 WHEN MATED TO METRAL 4000 RECEPT. (2.30 MIN IN NON-STANDARD REAR PLUG UP APPLICATIONS) NO PIN ALIGNER

METRAL P/N	ROW	CONTACT CODE											
		1	2	3	4	5	6	7	8	9	10	11	12
63784-X029 RPU FOR LEAD FREE SEE NOTE 15	H	01	01	01	01	01	01	01	01	01	01	01	01
	G	01	01	01	01	01	01	01	01	01	01	01	01
	F	01	01	01	01	01	01	01	01	01	01	01	01
	E	05	05	05	05	05	05	05	05	05	05	05	05
	D	05	05	05	05	05	05	05	05	05	05	05	05
	C	05	05	05	05	05	05	05	05	05	05	05	05
	B	05	05	05	05	05	05	05	05	05	05	05	05
	A	05	05	05	05	05	05	05	05	05	05	05	05
	GND	01	01	01	01	01	01	01	01	01	01	01	01

FOR REAR PLUG UP APPLICATIONS, PCB THICKNESS RANGE: 2.95 -5.30 WHEN MATED TO METRAL 1000 RECEPT. AND 3.30-5.30 WHEN MATED TO METRAL 4000 RECEPT. (2.30 MIN IN NON-STANDARD REAR PLUG UP APPLICATIONS) NO PIN ALIGNER

METRAL P/N	ROW	CONTACT CODE											
		1	2	3	4	5	6	7	8	9	10	11	12
63784-X030 RPU FOR LEAD FREE SEE NOTE 15	H	05	05	05	05	05	05	01	01	01	01	01	01
	G	05	05	05	05	05	05	01	01	01	01	01	01
	F	05	05	05	05	05	05	01	01	01	01	01	01
	E	05	05	05	05	05	05	01	01	01	01	01	01
	D	01	01	01	01	01	01	01	01	01	01	01	01
	C	01	01	01	01	01	01	01	01	01	01	01	01
	B	01	01	01	01	01	01	01	01	01	01	01	01
	A	01	01	01	01	01	01	01	01	01	01	01	01
	GND	01	01	01	01	01	01	01	01	01	01	01	01

FOR REAR PLUG UP APPLICATIONS, PCB THICKNESS RANGE: 2.95 -5.30 WHEN MATED TO METRAL 1000 RECEPT. AND 3.30-5.30 WHEN MATED TO METRAL 4000 RECEPT. (2.30 MIN IN NON-STANDARD REAR PLUG UP APPLICATIONS) NO PIN ALIGNER

METRAL P/N	ROW	CONTACT CODE											
		1	2	3	4	5	6	7	8	9	10	11	12
63784-X031 RPU FOR LEAD FREE SEE NOTE 15	H	05	05	05	05	05	05	05	05	05	05	05	05
	G	05	05	05	05	05	05	05	05	05	05	05	05
	F	05	05	05	05	05	05	05	05	05	05	05	05
	E	05	05	05	05	05	05	05	05	05	05	05	05
	D	19	19	19	19	19	19	19	19	19	19	19	19
	C	01	01	01	01	01	01	01	01	01	01	01	01
	B	01	01	01	01	01	01	01	01	01	01	01	01
	A	01	01	01	01	01	01	01	01	01	01	01	01
	GND	01	01	01	01	01	01	01	01	01	01	01	01

FOR REAR PLUG UP APPLICATIONS, PCB THICKNESS RANGE: 2.95 -5.30 WHEN MATED TO METRAL 1000 RECEPT. AND 3.30-5.30 WHEN MATED TO METRAL 4000 RECEPT. (2.30 MIN IN NON-STANDARD REAR PLUG UP APPLICATIONS) NO PIN ALIGNER

METRAL P/N	ROW	CONTACT CODE											
		1	2	3	4	5	6	7	8	9	10	11	12
63784-X032 RPU FOR LEAD FREE SEE NOTE 15	H	03	03	03	03	03	03	03	03	03	03	19	02
	G	03	03	03	03	03	03	03	03	03	03	19	19
	F	-	03	-	03	-	03	-	03	-	03	-	03
	E	41	41	41	41	41	41	41	41	03	03	19	19
	D	37	37	37	37	37	37	37	37	19	19	03	03
	C	50	50	50	50	50	50	50	50	03	03	19	19
	B	37	37	37	37	37	37	37	37	03	03	19	19
	A	50	50	50	50	50	50	50	50	03	03	19	19
	GND	06	06	06	06	06	06	06	06	02	02	02	02

FOR REAR PLUG UP APPLICATIONS, PCB THICKNESS RANGE: 4.30-5.70 WHEN MATED TO METRAL 1000 RECEPT. CANNOT BE MATED TO METRAL 4000 RECEPT. (2.30 MIN IN NON-STANDARD REAR PLUG UP APPLICATIONS)

mat'l code	ecr no.	dr	date
AL			

tolerances unless otherwise specified	CUSTOMER
0.xx ±0.3	COPY
.xxx ±.051	projection
° ±2°	MM
dr E. KROPER. 2001-01-10	scale
engr J. VOLSTORF 2001-01-10	1:1
ctr J. VOLSTORF 2001-01-10	
appd J. VOLSTORF 2001-01-10	

FCI		www.fciconnect.com	
title	VERTICAL SIGNAL HDR 8 ROW P.F. 96 POS. SELECT LOAD EXT.	product family	METRAL 1000
code	213	size	dwg no
sheet	g		63784
cage code		22526	

Pro/E 3 4

PDM: Rev:AL STATUS:Released Printed: Dec 17, 2009



This document is the property of and embodies CONFIDENTIAL and PROPRIETARY information of FCJ. No part of the information shown on this document may be used in any way or disclosed to others without the written consent of FCJ. Copyright FCJ.

METRAL P/N		CONTACT CODE											
ROW		1	2	3	4	5	6	7	8	9	10	11	12
63784-X037 FOR LEAD FREE SEE NOTE 15	H	03	02	02	03	02	03	02	02	02	02	03	02
	G	03	02	02	03	02	03	02	03	03	02	03	02
	F	03	02	02	03	03	03	03	02	02	03	03	02
	E	03	02	02	03	02	03	02	03	02	02	03	02
	D	03	02	02	03	02	03	02	03	02	02	03	02
	C	03	02	02	03	03	03	03	03	02	03	03	02
	B	03	02	02	03	02	03	02	02	02	02	03	02
	A	03	02	02	03	02	03	02	02	02	02	03	02
GND	02	02	02	02	02	02	02	02	02	02	02	02	

METRAL P/N		CONTACT CODE											
ROW		1	2	3	4	5	6	7	8	9	10	11	12
63784-X042 FOR LEAD FREE SEE NOTE 15	H	01	02	02	02	02	02	01	02	02	02	02	03
	G	02	02	02	02	02	02	02	02	02	02	02	03
	F	02	02	02	02	02	02	02	02	02	02	02	03
	E	02	02	02	02	02	02	02	02	02	02	02	03
	D	02	02	02	02	02	02	02	02	02	02	02	03
	C	02	02	02	02	02	02	02	02	02	02	02	03
	B	02	02	02	02	02	02	02	02	02	02	02	03
	A	02	02	02	02	02	02	02	02	02	02	02	03
GND	01	01	01	01	01	01	01	01	01	01	01	01	

METRAL P/N		CONTACT CODE											
ROW		1	2	3	4	5	6	7	8	9	10	11	12
63784-X038 FOR LEAD FREE SEE NOTE 15	H	02	02	02	19	-	19	-	02	-	02	-	19
	G	02	02	02	19	-	19	-	02	-	02	-	19
	F	02	-	02	19	-	19	-	-	-	02	-	19
	E	02	02	02	19	-	19	-	02	-	02	-	19
	D	02	02	02	19	-	19	-	02	-	02	-	19
	C	02	02	02	19	-	19	-	02	-	02	-	19
	B	02	02	02	19	-	19	-	02	-	02	-	19
	A	02	02	02	19	-	19	-	02	-	02	-	19
GND	-	-	-	-	-	-	-	-	-	-	-	-	

METRAL P/N		CONTACT CODE											
ROW		1	2	3	4	5	6	7	8	9	10	11	12
63784-X043 FOR LEAD FREE SEE NOTE 15	H	02	02	02	02	01	02	01	02	02	02	02	03
	G	02	02	02	02	01	02	02	02	02	02	02	03
	F	02	02	02	02	01	02	02	02	02	02	02	03
	E	02	02	02	02	01	02	02	02	02	02	02	03
	D	02	02	02	02	03	02	02	02	02	02	02	03
	C	02	02	02	02	03	02	02	02	02	02	02	03
	B	02	02	02	02	03	02	02	02	02	02	02	03
	A	02	02	02	02	03	02	02	02	02	02	02	03
GND	01	01	01	01	01	01	01	01	01	01	01	01	

METRAL P/N		CONTACT CODE											
ROW		1	2	3	4	5	6	7	8	9	10	11	12
63784-X039 FOR LEAD FREE SEE NOTE 15	H	02	02	02	02	02	02	02	02	03	03	03	03
	G	02	02	02	02	02	02	02	02	03	03	03	03
	F	02	02	02	03	02	02	02	02	03	03	03	03
	E	02	02	02	01	02	02	02	02	03	03	03	03
	D	03	01	02	01	02	02	02	02	03	03	03	03
	C	02	02	02	01	02	02	02	02	03	03	03	03
	B	02	02	02	01	02	02	02	02	03	03	03	03
	A	03	01	02	01	02	02	02	02	03	03	03	03
GND	01	01	01	01	01	01	01	01	01	01	01	01	

METRAL P/N		CONTACT CODE											
ROW		1	2	3	4	5	6	7	8	9	10	11	12
63784-X040 FOR LEAD FREE SEE NOTE 15	H	03	03	03	03	03	03	02	02	02	02	02	02
	G	03	03	03	03	03	03	02	02	02	02	02	02
	F	03	03	03	03	03	03	02	02	02	02	02	02
	E	03	03	03	03	03	03	02	02	02	02	02	02
	D	03	03	03	03	03	03	02	02	02	02	02	02
	C	03	03	03	03	03	03	02	02	02	02	02	02
	B	03	03	03	03	03	03	02	02	02	02	02	02
	A	03	03	03	03	03	03	02	02	02	02	02	02
GND	01	01	01	01	01	01	01	01	01	01	01	01	

METRAL P/N		CONTACT CODE											
ROW		1	2	3	4	5	6	7	8	9	10	11	12
63784-X041 FOR LEAD FREE SEE NOTE 15	H	02	02	02	02	02	02	02	02	02	02	02	02
	G	02	02	02	02	02	02	02	02	02	02	02	01
	F	02	02	02	02	02	02	02	02	02	02	02	01
	E	02	02	02	02	02	02	02	02	02	02	02	02
	D	02	02	02	02	02	02	02	02	02	02	02	03
	C	02	02	02	02	02	02	02	02	02	02	02	03
	B	02	02	02	02	02	02	02	02	02	02	02	03
	A	02	02	02	02	02	02	02	02	02	02	02	01
GND	01	01	01	01	01	01	01	01	01	01	01	01	

mat'l code: SEE NOTE 5		tolerances unless otherwise specified		CUSTOMER		FCJ	
lfr	ecn no.	dr	date	0.X ±0.3	COPY	www.fcjconnect.com	
AL				linear 0.XX ±0.13	projection	title VERTICAL SIGNAL HDR 8 ROW	
				.XXX ±.051		P.F. 96 POS. SELECT LOAD EXT.	
				angles 0° ±2°		product family METRAL 1000	
				dr E. KROPER 2001-01-10		code 213	
				engr J. VOLSTORF 2001-01-10		size 10	
				chr J. VOLSTORF 2001-01-10		63784	
				appd J. VOLSTORF 2001-01-10		sheet 10	
sheet index	revision sheet				scale 1:1	A	