

PRODUCT NUMBER	PLATING PERFORMANCE LEVEL	APPLICATION	SHROUD FOR REAR PLUG UP APPLICATIONS
63743-1YYY	TELCORDIA CO	STANDARD	84818-102
63743-1YYYYLF		LEAD FREE	84818-102LF
63743-5YYY	TELCORDIA UE	STANDARD	84818-502
63743-5YYYYLF		LEAD FREE	84818-502LF
63743-9YYY	TELCORDIA CO	STANDARD	84818-102
63743-9YYYYLF		LEAD FREE	84818-102LF

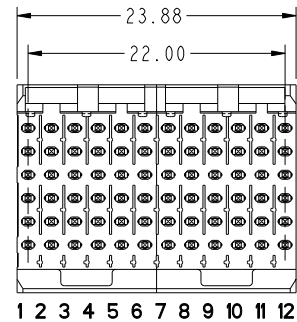

mat'l code				SEE NOTE 5		tolerances unless otherwise specified		CUSTOMER		FCJ	
ltr	ecm no.	dr	date	linear	0.X ±0.3	projection	COPY		www.fcjconnect.com		
P	V06-0498	DCH	2006-06-05		0.XX ±0.13		title		VERTICAL SIGNAL HDR 5 ROW		
R	V06-0779	DAI	2006-08-11		.XXX ±.051		P.F. 60 POS. SELECT LOAD STD.				
S	V07-0182	DCH	2007-04-20	angles	∅ ±2°		product family		METRAL 1000		
T	V07-0733	HTB	2008-01-02	dr	K. BELL 2000-03-15		size		dwg no		
U	V08-0049	LP	2008-2-4	engr	M. HAHN 2000-03-15		scale		213		
				chr	M. HAHN 2000-03-15		A		63743		
N	V05-0533	TAB	2005-06-01	oppd	M. HAHN 2000-03-15				sheet 1 of 6		
sheet index	revision sheet	U	U	U	U	U	U	U	U	U	U

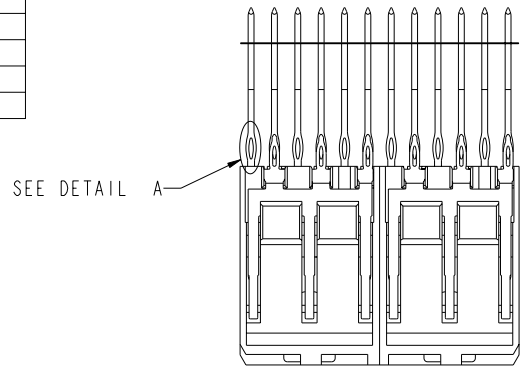
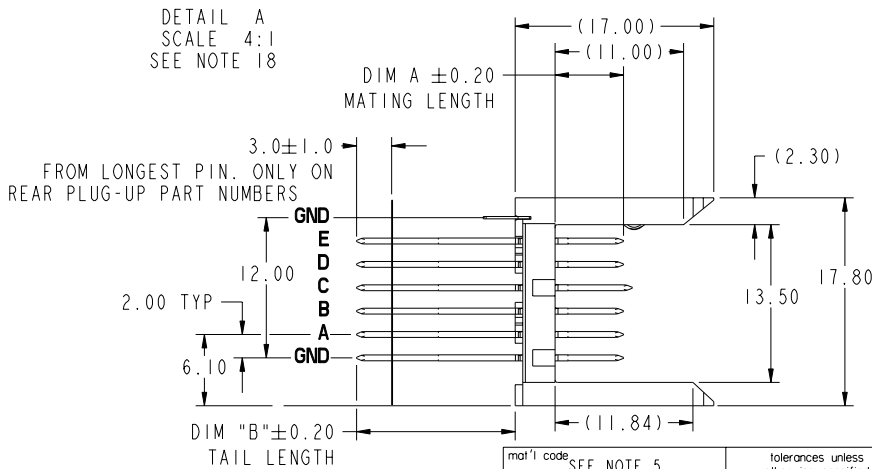

This document is the property of and embodies CONFIDENTIAL and PROPRIETARY information of FCJ. No part of the information shown on this document may be used in any way or disclosed to others without the written consent of FCJ. Copyright FCJ.

PRODUCT NUMBER
SEE SHEET 1

PRESS-FIT HOLES	OPTION 1	OPTION 2
HOLE DIAMETER AFTER PLATING	0.65-0.77	0.65-0.80
DRILLED HOLE	0.78-0.83	0.81-0.86 (0.85 DRILL)
COPPER PLATING	0.025-0.050	0.025 MIN
SnPb PLATING	0.005-0.015	0.005-0.015

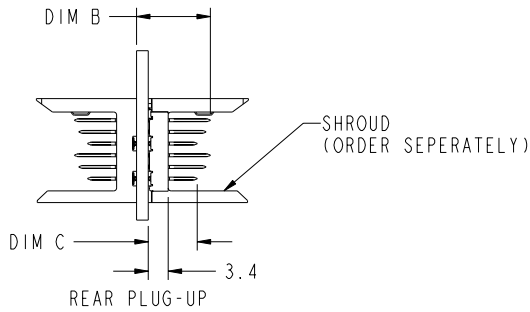

SEE PRINT 58351 FOR
ADDITIONAL PCB INFO.

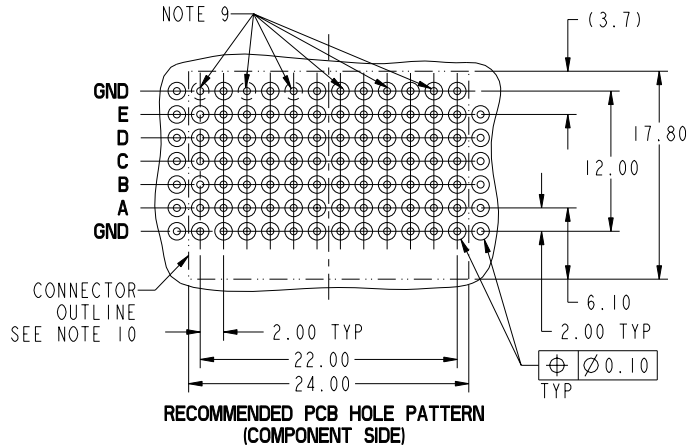
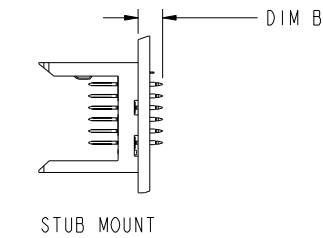

mat'l code		SEE NOTE 5		tolerances unless otherwise specified		CUSTOMER		FCJ		www.fcjconnect.com	
lfr	ecm no.	dr	date	linear	0.X ±0.3	projection	COPY	title		VERTICAL SIGNAL HDR 5 ROW	
U					0.XX ±0.13			P.F. 60 POS. SELECT LOAD STD.			
				angles	.XXX ±.051			product family		METRAL 1000	
				dr	0° ±2°			size		213	
				engr	K. BELL 2000-03-15			dwg no		63743	
				chr	M. HAHN 2000-03-15			scale		sheet	
				appd	M. HAHN 2000-03-15			1:1		2	
sheet index	revision sheet							code		22526	

This document is the property of and embodies
 CONFIDENTIAL and PROPRIETARY information of FCJ.
 No part of the information shown on this
 document may be used in any way or disclosed
 to others without the written consent of FCJ.
 Copyright FCJ.

REV E - 2006-04-18



This document is the property of and embodies CONFIDENTIAL and PROPRIETARY information of FCJ. No part of the information shown on this document may be used in any way or disclosed to others without the written consent of FCJ. Copyright FCJ.

PIN CODE NO.	DIM A MATING LENGTH	DIM B TAIL LENGTH	PCB THICKNESS RANGE ACCOMMODATED BY PIN'S TAIL LENGTH				
			WHEN MATING TO A 73981 OR 84688 SERIES RECEPTACLE		WHEN MATING TO A 52057 SERIES METRAL 4000 RECEPTACLE		
			ROWS A,B,C,D,E	GROUND ROW	ROWS:A,B,D,E	ROW C	GROUND ROW
01*	5.00	4.30	1.60 MIN	1.60 MIN	1.60 MIN	1.60 MIN	1.60 MIN
22		12.20	2.95 - 3.80	2.95 - 4.20	2.95 - 3.80	2.95 - 3.80	2.95 - 4.20
30		12.95	2.95 - 4.55	3.25 - 4.95	2.95 - 4.55	2.95 - 4.55	3.25 - 4.95
05		13.70	2.95 - 5.30	4.00 - 5.70	3.30 - 5.30	2.95 - 5.30	4.00 - 5.70
35		14.45	3.05 - 6.05	4.75 - 6.45	4.05 - 6.05	3.05 - 6.05	4.75 - 6.45
48		15.20	3.80 - 6.80	5.50 - 7.20	4.80 - 6.80	3.80 - 6.80	5.50 - 7.20
40		15.70	4.30 - 7.30	6.00 - 7.70	5.30 - 7.30	4.30 - 7.30	6.00 - 7.70
65		16.40	5.00 - 8.00	6.70 - 8.40	6.00 - 8.00	5.00 - 8.00	6.70 - 8.40
09		17.10	5.70 - 8.70	7.40 - 9.10	6.70 - 8.70	5.70 - 8.70	7.40 - 9.10
02*		5.75	4.30	1.60 MIN	1.60 MIN	1.60 MIN	1.60 MIN
44	12.20		2.95 - 3.80	2.95 - 4.20	2.95 - 3.80	2.95 - 3.80	2.95 - 4.20
31	12.95		2.95 - 4.55	3.25 - 4.95	2.95 - 4.55	2.95 - 4.55	3.25 - 4.95
06	13.70		2.95 - 5.30	4.00 - 5.70	3.30 - 5.30	2.95 - 5.30	4.00 - 5.70
36	14.45		3.05 - 6.05	4.75 - 6.45	4.05 - 6.05	3.05 - 6.05	4.75 - 6.45
49	15.20		3.80 - 6.80	5.50 - 7.20	4.80 - 6.80	3.80 - 6.80	5.50 - 7.20
25	15.70		4.30 - 7.30	6.00 - 7.70	5.30 - 7.30	4.30 - 7.30	6.00 - 7.70
66	16.40		5.00 - 8.00	6.70 - 8.40	6.00 - 8.00	5.00 - 8.00	6.70 - 8.40
10	17.10		5.70 - 8.70	7.40 - 9.10	6.70 - 8.70	5.70 - 8.70	7.40 - 9.10
03*	6.50		4.30	1.60 MIN	1.60 MIN	1.60 MIN	1.60 MIN
45		12.20	2.95 - 3.80	2.95 - 4.20	2.95 - 3.80	2.95 - 3.80	2.95 - 4.20
32		12.95	2.95 - 4.55	3.25 - 4.95	2.95 - 4.55	2.95 - 4.55	3.25 - 4.95
07		13.70	2.95 - 5.30	4.00 - 5.70	3.30 - 5.30	2.95 - 5.30	4.00 - 5.70
37		14.45	3.05 - 6.05	4.75 - 6.45	4.05 - 6.05	3.05 - 6.05	4.75 - 6.45
50		15.20	3.80 - 6.80	5.50 - 7.20	4.80 - 6.80	3.80 - 6.80	5.50 - 7.20
41		15.70	4.30 - 7.30	6.00 - 7.70	5.30 - 7.30	4.30 - 7.30	6.00 - 7.70
24		16.40	5.00 - 8.00	6.70 - 8.40	6.00 - 8.00	5.00 - 8.00	6.70 - 8.40
11		17.10	5.70 - 8.70	7.40 - 9.10	6.70 - 8.70	5.70 - 8.70	7.40 - 9.10

* STUB PINS - NO REAR PLUG-UP

** THE GREATEST RANGE OCCURS WHEN THE B DIMENSION OF PIN 'GND' IS ONE SIZE SHORTER THEN THE OTHER PINS.

mat'l code: SEE NOTE 5		tolerances unless otherwise specified		CUSTOMER		FCJ www.fcjconnect.com	
lfr	ecm no.	dr	date	linear	projection	title	
U				0.X ±0.3	MM	VERTICAL SIGNAL HDR 5 ROW	
				.XXX ±.051	MM	P.F. 60 POS. SELECT LOAD STD.	
				angles	MM	product family METRAL 1000	
				dr K. BELL 2000-03-15	MM	code 213	
				engr M. HAHN 2000-03-15	MM	size	
				chr M. HAHN 2000-03-15	MM	dwg no 63743	
				oppd M. HAHN 2000-03-15	MM	sheet 3	
sheet index	revision sheet					cage code 22526	



This document is the property of and embodies CONFIDENTIAL and PROPRIETARY information of FCI. No part of the information shown on this document may be used in any way or disclosed to others without the written consent of FCI. Copyright FCI.

PIN CODE NO.	DIM A MATING LENGTH	DIM B TAIL LENGTH	PCB THICKNESS RANGE ACCOMMODATED BY PIN LENGTH				
			WHEN MATING TO A 73981 OR 84688 SERIES RECEPTACLE		WHEN MATING TO A 52057 SERIES METRAL 4000 RECEPTACLE		
			ROWS A,B,C,D,E	GROUND ROW	ROWS:A,B,D,E	ROW C	GROUND ROW
04*	7.25	4.30	1.60 MIN	1.60 MIN	1.60 MIN	1.60 MIN	1.60 MIN
46		12.20	2.95 - 3.80	2.95 - 4.20	2.95 - 3.80	2.95 - 3.80	2.95 - 4.20
33		12.95	2.95 - 4.55	3.25 - 4.95	2.95 - 4.55	2.95 - 4.55	3.25 - 4.95
08		13.70	2.95 - 5.30	4.00 - 5.70	3.30 - 5.30	2.95 - 5.30	4.00 - 5.70
38		14.45	3.05 - 6.05	4.75 - 6.45	4.05 - 6.05	3.05 - 6.05	4.75 - 6.45
51		15.20	3.80 - 6.80	5.50 - 7.20	4.80 - 6.80	3.80 - 6.80	5.50 - 7.20
42		15.70	4.30 - 7.30	6.00 - 7.70	5.30 - 7.30	4.30 - 7.30	6.00 - 7.70
67		16.40	5.00 - 8.00	6.70 - 8.40	6.00 - 8.00	5.00 - 8.00	6.70 - 8.40
12		17.10	5.70 - 8.70	7.40 - 9.10	6.70 - 8.70	5.70 - 8.70	7.40 - 9.10
19*		8.00	4.30	1.60 MIN	1.60 MIN	1.60 MIN	1.60 MIN
47	12.20		2.95 - 3.80	2.95 - 4.20	2.95 - 3.80	2.95 - 3.80	2.95 - 4.20
34	12.95		2.95 - 4.55	3.25 - 4.95	2.95 - 4.55	2.95 - 4.55	3.25 - 4.95
20	13.70		2.95 - 5.30	4.00 - 5.70	3.30 - 5.30	2.95 - 5.30	4.00 - 5.70
39	14.45		3.05 - 6.05	4.75 - 6.45	4.05 - 6.05	3.05 - 6.05	4.75 - 6.45
52	15.20		3.80 - 6.80	5.50 - 7.20	4.80 - 6.80	3.80 - 6.80	5.50 - 7.20
43	15.70		4.30 - 7.30	6.00 - 7.70	5.30 - 7.30	4.30 - 7.30	6.00 - 7.70
68	16.40		5.00 - 8.00	6.70 - 8.40	6.00 - 8.00	5.00 - 8.00	6.70 - 8.40
21	17.10		5.70 - 8.70	7.40 - 9.10	6.70 - 8.70	5.70 - 8.70	7.40 - 9.10

* STUB PINS - NO REAR PLUG-UP

** THE GREATEST RANGE OCCURS WHEN THE B DIMENSION OF PIN 'GND' IS ONE SIZE SHORTER THEN THE OTHER PINS.

mat'l code		SEE NOTE 5		tolerances unless otherwise specified		CUSTOMER		FCI		www.fciconnect.com	
lfr	ecm no.	dr	date	linear	0.X ± 0.3	projection	COPY	title			
u				angles	.XXX ± .051	MM		VERTICAL SIGNAL HDR 5 ROW			
				dr	0° ± 2°	MM		P.F. 60 POS. SELECT LOAD STD.			
				enr		MM		product family		METRAL 1000	code
				chr	K. BELL 2000-03-15	MM		size		dwg no	213
				oppd	M. HAHN 2000-03-15	MM		A		63743	sheet
					M. HAHN 2000-03-15	MM		scale		4	4
sheet index	revision sheet										

REV E - 2004-04-18

1 | 2

Pro/E

3 |

cage code 22526

4

PDM: Rev:U STATUS:Released Printed: Dec 17, 2009



This document is the property of and embodies CONFIDENTIAL and PROPRIETARY information of FCI. No part of the information shown on this document may be used in any way or disclosed to others without the written consent of FCI. Copyright FCI.

SELECT LOAD PATTERNS													
METRAL P/N	ROW	1	2	3	4	5	6	7	8	9	10	11	12
63743-X001 FOR LEAD FREE SEE NOTE 16	E	02	02	02	02	02	02	02	02	02	02	02	02
	D	02	02	02	02	02	02	02	02	02	02	02	02
	C	04	04	04	04	04	04	04	04	04	04	04	04
	B	02	02	02	02	02	02	02	02	02	02	02	02
	A	02	02	02	02	02	02	02	02	02	02	02	02
GND	02	02	02	02	02	02	02	02	02	02	02	02	

METRAL P/N	ROW	1	2	3	4	5	6	7	8	9	10	11	12
63743-X006 FOR LEAD FREE SEE NOTE 16	E	01	01	01	01	01	01	01	01	01	01	01	01
	D	02	01	01	01	01	01	02	01	01	01	01	01
	C	02	01	01	01	01	01	02	01	01	01	01	01
	B	03	03	03	03	03	03	03	03	03	03	03	03
	A	01	01	01	01	01	01	01	01	01	01	01	01
GND	01	01	01	01	01	01	01	01	01	01	01	01	

METRAL P/N	ROW	1	2	3	4	5	6	7	8	9	10	11	12
63743-X011 FOR LEAD FREE SEE NOTE 16	E	55	55	55	55	55	55	55	55	55	55	55	55
	D	55	55	55	55	55	55	55	55	55	55	55	55
	C	55	55	55	55	55	55	55	55	55	55	55	55
	B	55	55	55	55	55	55	55	55	55	55	55	55
	A	55	55	55	55	55	55	55	55	55	55	55	55
GND	55	55	55	55	55	55	55	55	55	55	55	55	

METRAL P/N	ROW	1	2	3	4	5	6	7	8	9	10	11	12
63743-X012 FOR LEAD FREE SEE NOTE 16	E	02	02	02	02	02	02	02	02	02	02	02	02
	D	02	02	02	02	02	02	02	02	02	02	02	02
	C	02	02	02	02	02	02	02	02	02	02	02	02
	B	02	02	02	02	02	02	02	02	02	02	02	02
	A	02	02	02	02	02	02	02	02	02	02	02	02
GND	-	02	02	02	02	-	-	02	02	02	02	-	

METRAL P/N	ROW	1	2	3	4	5	6	7	8	9	10	11	12
63743-X007 FOR LEAD FREE SEE NOTE 16	E	02	02	02	02	02	02	02	02	02	02	02	02
	D	02	02	02	02	02	02	02	02	02	02	02	02
	C	02	02	02	02	02	02	02	02	02	02	02	02
	B	02	02	02	02	02	02	02	02	02	02	02	02
	A	02	02	02	02	02	02	02	02	02	02	02	02
GND	02	02	02	02	02	02	02	02	02	02	02	02	

METRAL P/N	ROW	1	2	3	4	5	6	7	8	9	10	11	12
63743-X008 FOR LEAD FREE SEE NOTE 16	E	02	02	02	02	01	02	02	02	02	02	02	02
	D	02	02	02	02	02	02	02	02	02	02	02	02
	C	02	02	02	02	02	02	02	02	02	02	02	02
	B	02	02	02	02	03	02	02	02	02	02	02	03
	A	02	02	02	02	02	02	02	02	02	02	02	02
GND	02	02	02	02	02	02	02	02	02	02	02	02	

METRAL P/N	ROW	1	2	3	4	5	6	7	8	9	10	11	12
63743-X009 *RPU FOR LEAD FREE SEE NOTE 16	E	06	05	06	05	06	05	06	05	06	05	06	05
	D	06	06	06	06	06	05	06	05	05	05	05	05
	C	06	05	05	05	05	05	06	05	05	05	05	05
	B	06	05	05	05	05	05	06	05	05	05	05	05
	A	06	05	05	05	05	05	06	05	05	05	05	05
GND	31	31	31	31	31	31	31	31	31	31	31	31	

PCB THICKNESS RANGE FOR REAR PLUG UP APPLICATIONS: 3.25 - 4.99 FOR METRAL 1000 RECEPTACLE APPLICATIONS AND 3.30 - 4.95 FOR METRAL 4000 APPLICATIONS

NOT A STANDARD METRAL 1000 OR METRAL 4000 APPLICATION

METRAL P/N	ROW	1	2	3	4	5	6	7	8	9	10	11	12
63743-X004 FOR LEAD FREE SEE NOTE 16	E	19	02	02	02	02	02	02	02	02	02	02	02
	D	19	02	02	02	02	02	02	02	02	02	02	02
	C	19	02	02	02	02	02	02	02	02	02	02	02
	B	19	02	02	02	02	02	02	02	02	02	02	02
	A	19	02	02	02	02	02	02	02	02	02	02	02
GND	02	02	02	02	02	02	02	02	02	02	02	02	

METRAL P/N	ROW	1	2	3	4	5	6	7	8	9	10	11	12
63743-X005 FOR LEAD FREE SEE NOTE 16	E	01	01	01	01	01	01	01	01	01	01	01	01
	D	01	01	01	01	01	02	01	01	01	01	01	02
	C	01	01	01	01	01	01	01	01	01	01	01	01
	B	01	01	01	01	01	01	01	01	01	01	01	01
	A	01	01	03	01	01	03	01	01	03	01	01	03
GND	01	01	01	01	01	01	01	01	01	01	01	01	

mat'l code: SEE NOTE 5		tolerances unless otherwise specified		CUSTOMER	FCI www.fciconnect.com
lfr	ecr no.	dr	date	COPY	
U				projection	title VERTICAL SIGNAL HDR 5 ROW P.F. 60 POS. SELECT LOAD STD.
				linear 0.XX ±.03	
				angles .XXX ±.051	product family METRAL 1000 code 213
				dr K. BELL 2000-03-15	
				engr M. HAHN 2000-03-15	size dwg no 63743 sheet 5
				chr M. HAHN 2000-03-15	
				appd M. HAHN 2000-03-15	scale 1:1
sheet index	revision sheet				

PRODUCT NUMBER
SEE SHEET 1

NOTES:

1. SEE APPLICATION SPECIFICATION GS-20-010 FOR INFORMATION ON AVAILABLE TOOLING, CIRCUIT BOARD DESIGN CONSIDERATIONS, REPAIR PROCEDURES AND PRODUCT OFFERINGS.
2. SEE FCI PUBLICATION 950511-028 FOR "ELECTRICAL PERFORMANCE DATA FOR DIFFERENTIAL APPLICATIONS."
3. SEE FCI PUBLICATION 950511-029 FOR "ELECTRICAL PERFORMANCE DATA FOR SINGLE-ENDED APPLICATION."
4. UNLESS OTHERWISE SPECIFIED, ALL DIMENSIONS AND TOLERANCES ARE IN ACCORDANCE WITH ASME Y14.5, 1994
5. HOUSING MATERIAL: LIQUID CRYSTAL POLYMER, 30% GLASS FILLED, FLAME RETARDANT PER UL 94-V0.
PIN MATERIAL: PHOSPHER BRONZE
GROUND SPRING MATERIAL: PHOSPHER BRONZE
6. PLATING INFORMATION: PLATING IN CONTACT AREAS MEET PERFORMANCE LEVELS SHOWN IN TABLE ON SHEET 1.
PLATING ON "LF" TAILS IS Sn ONLY, ALL OTHERS ARE SnPb.
7. DIMENSIONAL RESTRICTIONS OF PINS IN HEADERS.
FOR MATING WITH METRAL 1000 RECEPTACLES
DIM A : 5.00mm MIN, 8.00mm MAX FOR ROWS A-E
DIM A : 5.00mm MIN, 5.75mm MAX FOR ROW GND NEXT TO ROW A
DIM C : 5.00mm MIN, 8.00mm MAX FOR ROWS A-E
DIM C : 4.60mm MIN, 6.30mm MAX FOR ROW GND NEXT TO ROW A
FOR MATING WITH METRAL 4000 RECEPTACLES
DIM A : 5.00mm MIN, 6.50mm MAX FOR ROWS A, B, D & E
DIM A : 5.00mm MIN, 8.00mm MAX FOR ROW C
DIM A : 5.00mm MIN, 5.75mm MAX FOR ROW GND NEXT TO ROW A
DIM C : 5.00mm MIN, 7.00mm MAX FOR ROWS A, B, D & E
DIM C : 5.00mm MIN, 8.00mm MAX FOR ROW C
DIM C : 4.60mm MIN, 6.30mm MAX FOR ROW GND NEXT TO ROW A
8. THE MIN PCB THICKNESS FOR REAR PLUG-UP APPLICATIONS IS 2.9mm SINCE THE COMPLIANT SECTIONS OF THE GROUND SPRING OF THE HEADER DIRECTLY OPPOSE THE GROUND SPRING OF THE SHROUD.
THE MIN PCB THICKNESS FOR FRONT PLUG-UP ONLY APPLICATIONS IS 1.6mm.

9. THESE HOLES ARE NEEDED FOR REAR PLUG-UP DESIGNS USING A SHROUD AND MAY BE OMITTED FOR FRONT PLUG-UP ONLY DESIGNS.
10. THE 'CONNECTOR OUTLINE' IS THE MIN OUTLINE REQUIRED. TO DETERMINE THE OUTLINE NECESSARY TO PERMIT THE VARIOUS TYPES OF REPAIR OPERATIONS, SEE APPLICATION SPECIFICATION GS-20-010.
11. CURRENT RATING: 1 AMP PER PIN
12. TEMPERATURE RANGE: -55°C TO +105°C
13. P/N 63743-XXXXLF
 - LEAD FREE (OPTIONAL)
 - SELECT LOAD PATTERN
 - PLATING CODE
14. A PLATING HAS Au FLASH IN PRESS-FIT AREA (LEAD FREE).
15. THE PRODUCTS WHERE THE PART NUMBER ENDS IN LF MEET THE EUROPEAN UNION DIRECTIVES AND OTHER COUNTRY REGULATIONS AS DESCRIBED IN GS-22-008.

ALL PRODUCTS WILL WITHSTAND EXPOSURE TO 260°C FOR 60 SECONDS IN A CONVECTION, INFRA-RED OR VAPOR PHASE REFLOW OVEN.
16. FOR LEAD FREE PART NUMBERS, ADD AN "LF" SUFFIX.
EXAMPLE: 63743-X01LF
17. EQUIVALENT PRECIOUS METAL PLATINGS MAY BE SUBSTITUTED.
18. PIN TYPE IS AT THE MANUFACTURERS OPTION AND CAN BE EITHER BABY-H OR EYE OF THE NEEDLE STYLE



This document is the property of and embodies CONFIDENTIAL and PROPRIETARY information of FCI. No part of the information shown on this document may be used in any way or disclosed to others without the written consent of FCI. Copyright FCI.

mat'l code SEE NOTE 5				tolerances unless otherwise specified		CUSTOMER		FCI www.fciconnect.com	
ltr	ecm no.	dr	date	linear	0, X ±0.3	COPY		projection	title VERTICAL SIGNAL HDR 5 ROW P.F. 60 POS. SELECT LOAD STD.
U					.XXX ±.051	MM			
				angles	0° ±2°	scale		product family METRAL 1000	code 213
				dr	K. BELL 2000-03-15	1:1			
				engr	M. HAHN 2000-03-15			dwg no	63743
				chr	M. HAHN 2000-03-15				
				appd	M. HAHN 2000-03-15				
sheet index	revision sheet								

cage code 22526 4