

PRODUCT NO.	REMARKS
62453-022LF	WITH METAL PLATE(M2 SCREWS)

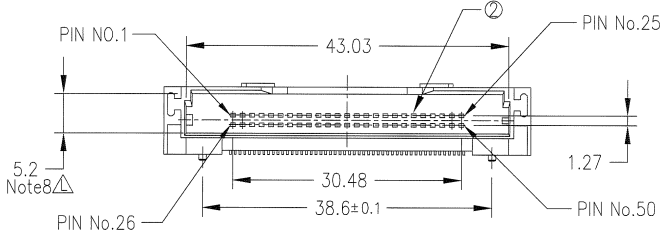
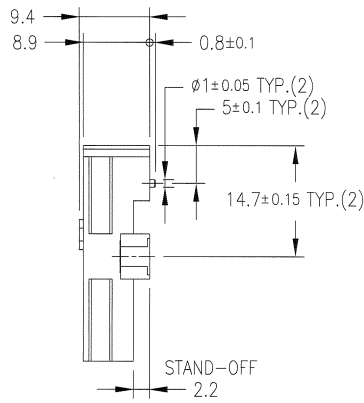
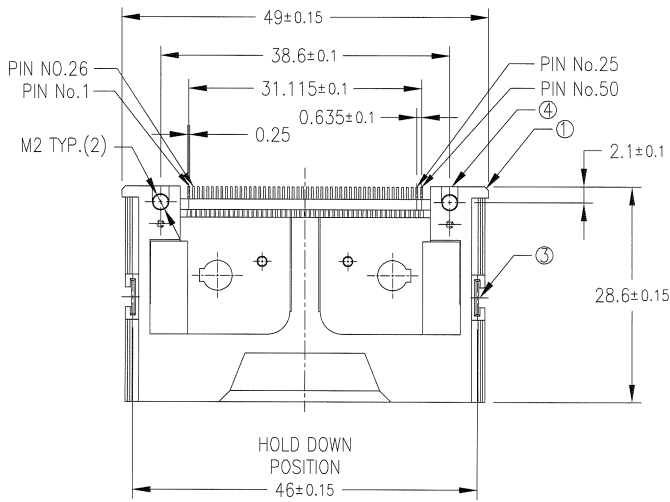

COMPONENT	MATERIAL	FINISH	QTY.
① HOUSING	FLAME RETARDANT RESIN	NONE (BLACK)	1
② PIN	PHOSPHOR BRONZE	UNDER : 1.0µm MIN. Ni CONTACT AREA : 0.2µm MIN. Au SOLDER TAIL : 0.05µm MIN. Au	50
③ HOLD DOWN	PHOSPHOR BRONZE	UNDER : 1.27µm MIN. Ni SOLDER TAIL : 2.0µm MIN. Sn	2
④ METAL PLATE	BRASS	2µm MIN. Ni	2

mat'l. code	---	surface	ISO 1302	tolerance	ISO 408	projection	product family	CODE
ltr	description	ecn no	dr	date	tolerances unless otherwise specified	mm	5AZF - CF HEADER	JP
F	ADDED SHEET	J04-0061	HS	2/19/04	0.X ±0.3	mm	COMPACT FLASH HDR TOP MOUNT	sheet 1 of 8 size
G	ADDED SHEET	J05-0357	M.H	6/16/05	0.XX ±0.3	mm		
H	REVISED	J05-0748	R.S	10/31/05	0'±2'	mm	62453	A3
J	REVISED	J06-0315	R.S	8/1/06	0.XXX ±0.3	mm		
K	REVISED	J06-0399	R.S	10/20/06	S.WATANABE 7/28/08	mm	type	Product Customer Drawing
L	REVISED	J08-0316	S.W	7/28/08	S.WATANABE 7/28/08	mm		
sheet index	revision sheet	L	J	E	E	E	E	Rev.
		1	2	3	4	5	6	L

PRODUCT NO.	REMARKS
62453-022LF	WITH METAL PLATE (M2 SCREWS)

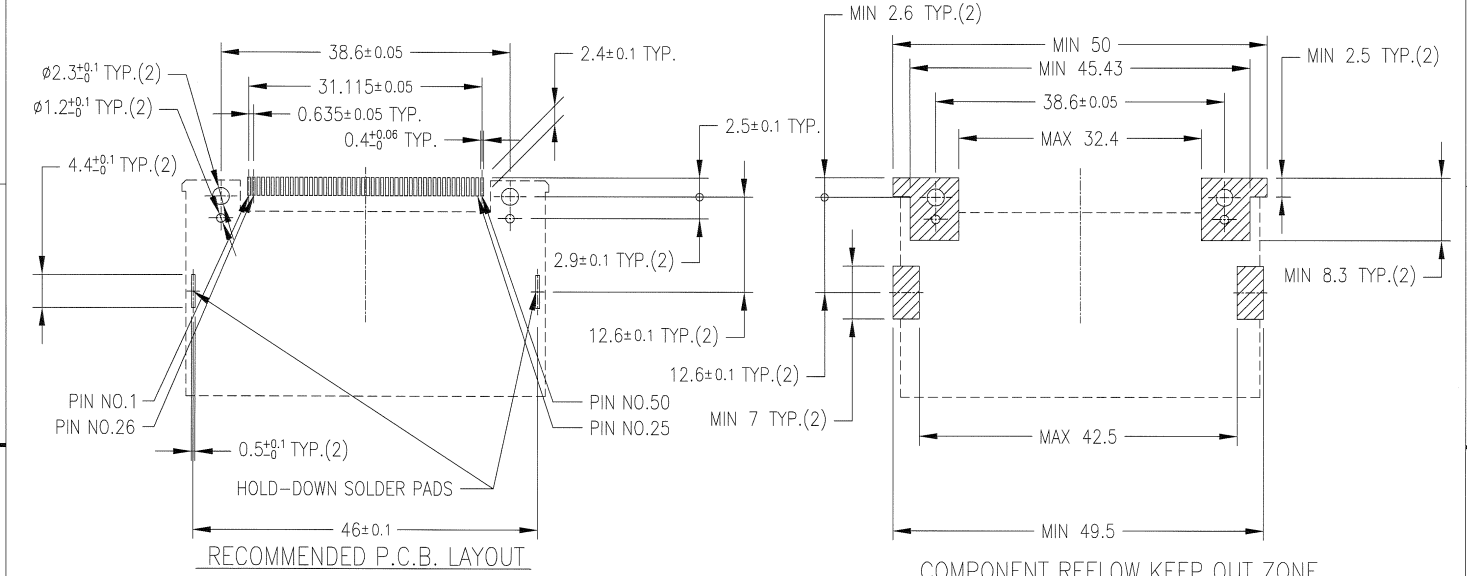

- NOTE
- 1.PRODUCT SPECIFICATION : 110-404
 - 2.PACKAGING SPECIFICATION : GES-14-620
 - 3.RECOMMENDED TIGHTENING TORQUE : 0.127N.m [1.3kgf.cm]
 - 4.SOLDER TAIL CO-PLANARITY : MAX 0.1
 - 5.RECOMMENDED HOLD-DOWN SCREW
M 2mm X 6mm SCREWS
FOR 0.062in/1.57mm THICK PCB
 - 6.FOR LEAD FREE P/N, THE PRODUCT MEETS EUROPEAN UNION DIRECTIVES AND OTHER COUNTRY REGULATIONS AS DESCRIBED IN GS-22-008.
 - 7.THE HOUSING WILL WITHSTAND EXPOSURE TO 260°C PEAK TEMPERATURE FOR 10 SECONDS IN A CONVENTION, INTRA-RED OR VAPOR PHASE REFLOW OVEN.
 - 8.MEASURED AT THE BOTTOM.

mat'l. code				surface	tolerance	projection	product family	CODE
---				ISO 1302	ISO 406	ISO 1101	5AZF - CF HEADER	JP
ltr	description	ecn no	dr	date	tolerances unless otherwise specified	mm	title	
D	REVISED	V20696	HS	5/15/02	0.X	± 0.3	COMPACT FLASH HDR	
E	ADDED SHEET	3,4	HS	12/25/02	0.XX	± 0.3	TOP MOUNT	
F	REVISED	J05-0748	R.S	10/31/08	0.XXX	± 0.3	scale 2:1	
G	REVISED	J06-0315	R.S	8/1/06	dr	S.WATANABE	7/28/08	dwg no
H	REVISED	J06-0399	R.S	10/20/08	enagr	S.WATANABE	7/28/08	sheet 2 of 8 size
J	REVISED	J08-0316	S.W	7/28/08	chr	J. Watanabe	2008-7-29	62453
					appd	J. Watanabe	2008-7-29	A3
sheet	revision							type
index	sheet							Product Customer Drawing
								Rev.
								J

PRODUCT NO.	REMARKS
62453-122LF	WITHOUT METAL PLATE(M2 SCREWS)

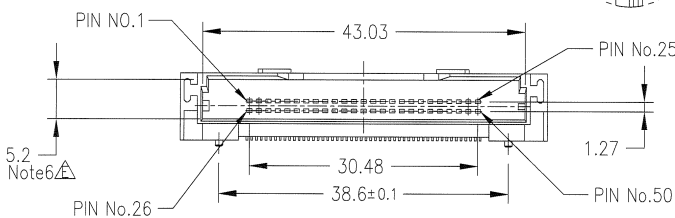
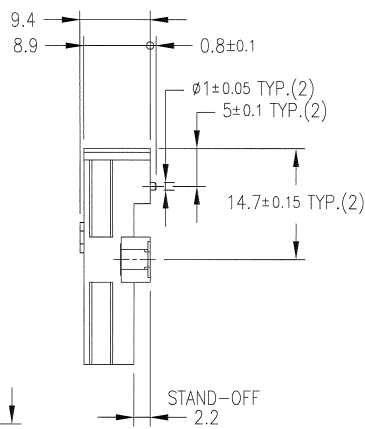
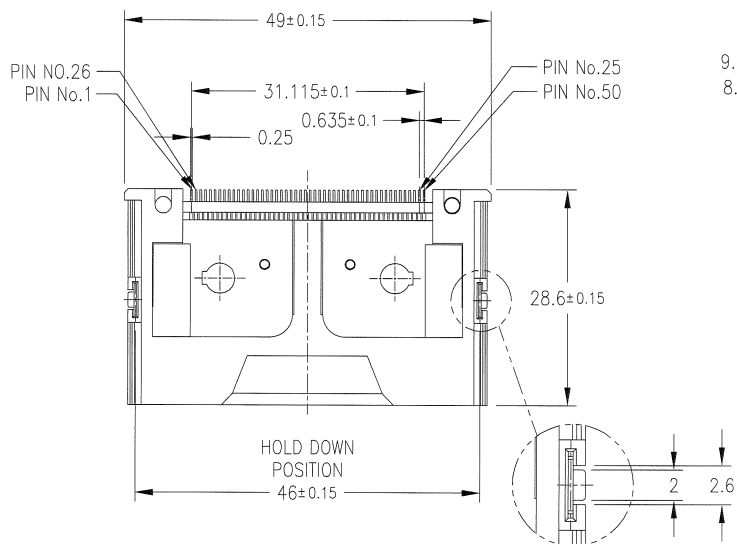

COMPONENT	MATERIAL	FINISH	QTY.
① HOUSING	FLAME RETARDANT RESIN	NONE (BLACK)	1
② PIN	PHOSPHOR BRONZE	UNDER : 1.0 μ m MIN. Ni CONTACT AREA : 0.2 μ m MIN. Au SOLDER TAIL : 0.05 μ m MIN. Au	50
③ HOLD DOWN	PHOSPHOR BRONZE	UNDER : 1.27 μ m MIN. Ni SOLDER TAIL : 2.0 μ m MIN. Sn	2

ltr	description	ecn no	dr	date	surface	tolerance	projection	product family	CODE
A	RELEASED	J20659	HS	2/18/04	ISO 1302	ISO 206	ISO 1101	5AZF - CF HEADER	JP
B	REVISED	J05-0748	R.S	10/31/05	tolerances unless otherwise specified	0.X	mm	COMPACT FLASH HDR	
C	REVISED	J06-0315	R.S	8/1/06	angles	linear	0.XXX	TOP MOUNT	
D	REVISED	J06-0399	R.S	10/20/06	0'±2'	0.XXX	scale 2:1	dwg no	sheet 3 of 8 size
E	REVISED	J08-0316	S.W	7/28/08	dr	S.WATANABE	7/28/08	62453	A3
					chr	S.WATANABE	7/28/08	type	Product Customer Drawing
					appd	J. Nakamura	2008-7-27	Rev.	E

PRODUCT NO.	REMARKS
62453-122LF	WITHOUT METAL PLATE(M2 SCREWS)

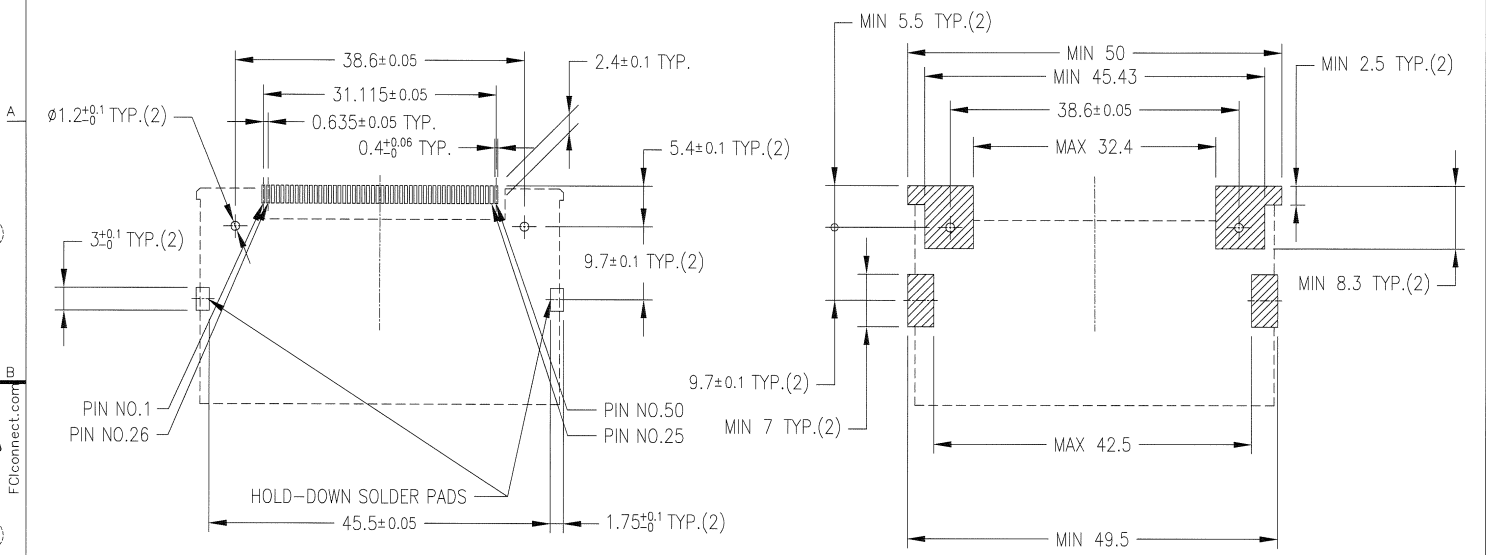

RECOMMENDED P.C.B. LAYOUT

COMPONENT REFLOW KEEP OUT ZONE

NOTE

- 1.PRODUCT SPECIFICATION : 110-404
- 2.PACKAGING SPECIFICATION : GES-14-620
- 3.SOLDER TAIL CO-PLANARITY : MAX 0.1
- 4.FOR LEAD FREE P/N, THE PRODUCT MEETS EUROPEAN UNION DIRECTIVES AND OTHER COUNTRY REGULATIONS AS DESCRIBED IN GS-22-008.
- 5.THE HOUSING WILL WITHSTAND EXPOSURE TO 260°C PEAK TEMPERATURE FOR 10 SECONDS IN A CONVENTION, INTRA-RED OR VAPOR PHASE REFLOW OVEN.
- 6.MEASURED AT THE BOTTOM.

mat'l. code				surface		tolerance	projection	product family	CODE
---				ISO 1302	ISO 428	ISO 1101	ISO 1101	5AZF - CF HEADER	JP
ltr	description	ecn no	dr	date	tolerances unless otherwise specified	angles	linear	title	
1	RELEASED		HS	9/12/02	0.X	±0.3	mm	COMPACT FLASH HDR	
A	RELEASED	J20659	HS	12/25/02	0°±2'	±0.3	scale 2:1	TOP MOUNT	
B	REVISED	J05-0748	R.S	10/31/05	0.XXX	±0.3			
C	REVISED	J06-0315	R.S	8/1/06	dr	S.WATANABE	7/28/08	dwg no	sheet 4 of 8 size
D	REVISED	J06-0399	R.S	10/20/06	enrg	S.WATANABE	7/28/08	62453	A3
E	REVISED	J08-0316	S.W	7/28/08	chr	2008-7-29		type	Product Customer Drawing
					appd	2008-7-29		Rev.	E
sheet index	revision sheet								

PRODUCT NO.	REMARKS
62453-222LF	WITH METAL PLATE(M2 SCREWS)

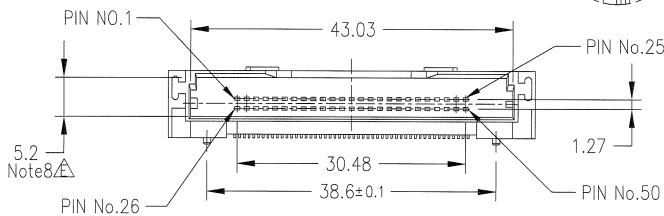
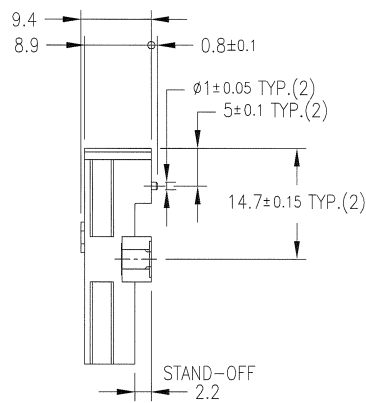
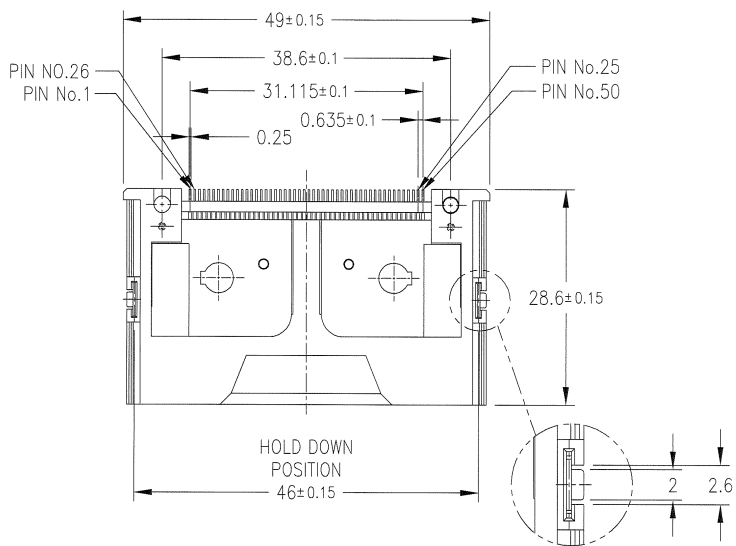

COMPONENT	MATERIAL	FINISH	QTY.
① HOUSING	FLAME RETARDANT RESIN	NONE (BLACK)	1
② PIN	PHOSPHOR BRONZE	UNDER : 1.0μm MIN. Ni CONTACT AREA : 0.2μm MIN. Au SOLDER TAIL : 0.05μm MIN. Au	50
③ HOLD DOWN	PHOSPHOR BRONZE	UNDER : 1.27μm MIN. Ni SOLDER TAIL : 2.0μm MIN. Sn	2
④ METAL PLATE	BRASS	2μm MIN. Ni	2

mat'l. code	surface	tolerance	projection	product family	CODE
---	ISO 1302	ISO 208	ISO 1101	5AZF - CF HEADER	JP
ltr	description	ecn no	dr	date	tolerances unless otherwise specified
A	RELEASED	J04-0061	YO	2/18/04	0.X ±0.3
B	REVISED	J05-0748	R.S	10/31/05	angles linear 0.XXX ±0.3
C	REVISED	J06-0315	R.S	8/1/06	0'±2'
D	REVISED	J06-0399	R.S	10/20/06	dr S.WATANABE 7/28/08
E	REVISED	J08-0316	S.W	7/28/08	enrg S.WATANABE 7/28/08
					chr P. Watanabe 2008-7-29
					appd P. Watanabe 2008-7-29
sheet index	revision sheet				

PRODUCT NO.	REMARKS
62453-222LF	WITH METAL PLATE(M2 SCREWS)

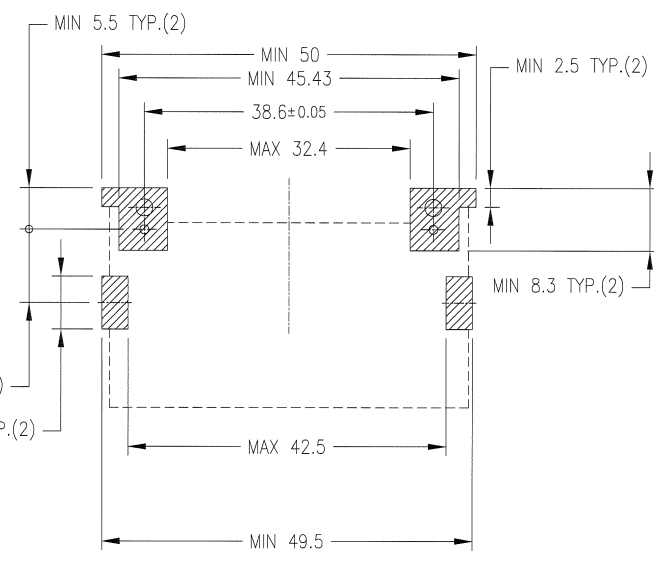
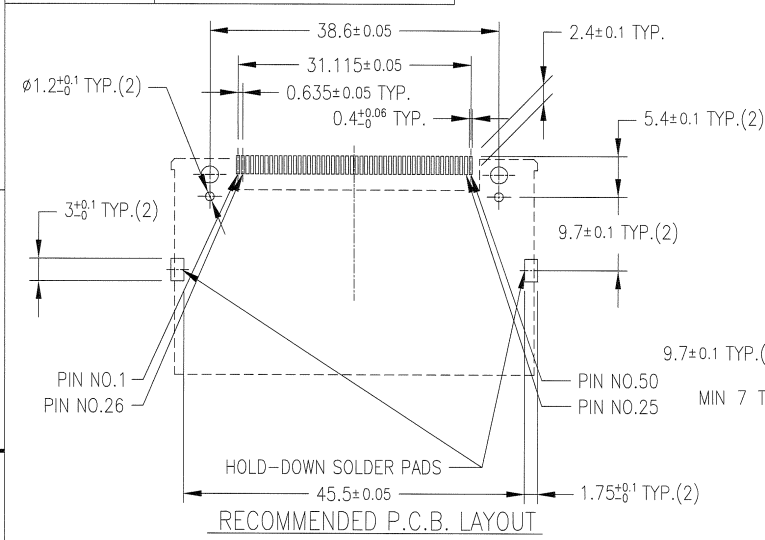

- NOTE
- 1.PRODUCT SPECIFICATION : 110-404
 - 2.PACKAGING SPECIFICATION : GES-14-620
 - 3.RECOMMENDED TIGHTENING TORQUE : 0.127N.m [1.3kgf.cm]
 - 4.SOLDER TAIL CO-PLANARITY : MAX 0.1
 - 5.RECOMMENDED HOLD-DOWN SCREW
M 2mm X 6mm SCREWS(FCI P/N ; 95121-001)
FOR 0.062in/1.57mm THICK PCB
 - 6.FOR LEAD FREE P/N, THE PRODUCT MEETS EUROPEAN UNION DIRECTIVES AND OTHER COUNTRY REGULATIONS AS DESCRIBED IN GS-22-008.
 - 7.THE HOUSING WILL WITHSTAND EXPOSURE TO 260°C PEAK TEMPERATURE FOR 10 SECONDS IN A CONVENTION, INTRA-RED OR VAPOR PHASE REFLOW OVEN.
 - 8.MEASURED AT THE BOTTOM.

mat'l. code				surface	tolerance	projection	product family	CODE
---				ISO 1302	ISO 406	ISO 1101	5AZF - CF HEADER	JP
ltr	description	ecn no	dr	date	tolerances unless otherwise specified	mm	title	
1	RELEASED		HS	9/12/02	0.X ±0.3	mm	COMPACT FLASH HDR	
A	RELEASED	J20659	HS	12/25/02	0°±2'	mm	TOP MOUNT	
B	REVISED	J05-0748	R.S	10/31/05	0.XXX ±0.3	scale 2:1		
C	REVISED	J06-0315	R.S	8/1/06	dr	S.WATANABE	7/28/08	
D	REVISED	J06-0399	R.S	10/20/06	enrg	S.WATANABE	7/28/08	
E	REVISED	J08-0316	S.W	7/28/08	chr			
sheet index				revision	type Product Customer Drawing			
sheet				sheet	Rev. E			

PRODUCT NO.	REMARKS
62453-622LF	WITHOUT METAL PLATE(M2 SCREWS)

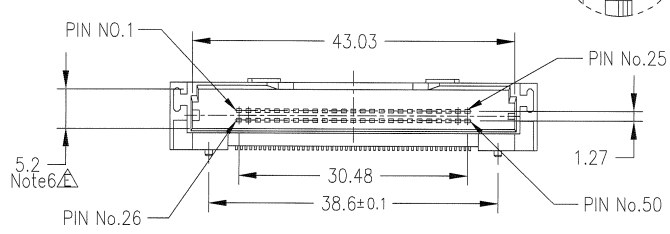
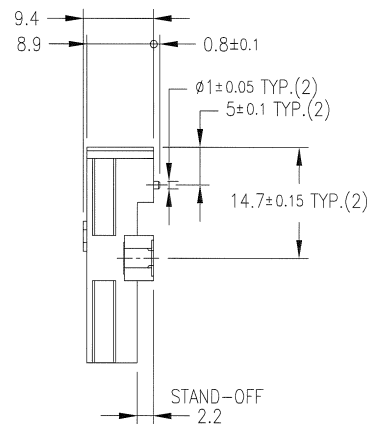
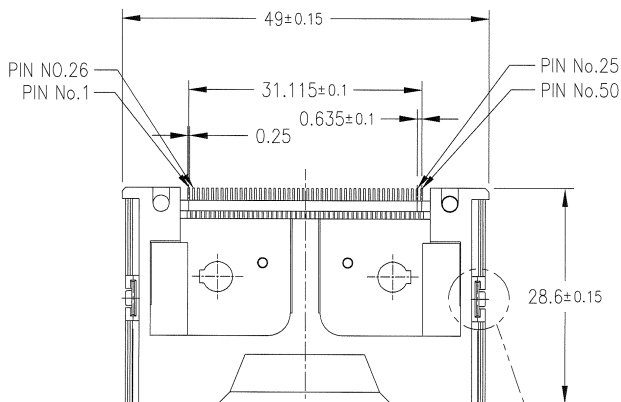

COMPONENT	MATERIAL	FINISH	QTY.
① HOUSING	FLAME RETARDANT RESIN	NONE (BLACK)	1
② PIN	PHOSPHOR BRONZE	UNDER : 1.0μm MIN. Ni CONTACT AREA : 0.76μm MIN. Au SOLDER TAIL : 0.05μm MIN. Au	50
③ HOLD DOWN	PHOSPHOR BRONZE	UNDER : 1.27μm MIN. Ni SOLDER TAIL : 2.0μm MIN. Sn	2

mat'l. code ---				surface	tolerance	projection	product family	CODE
				ISO 1302	ISO 408	ISO 1101	5AZF - CF HEADER	JP
				tolerances unless otherwise specified	0.X	±0.3	title	
				angles	linear	0.XX	COMPACT FLASH HDR	
				0°±2'	0.XXX	±0.3	TOP MOUNT	
				dr	scale 2:1		dwg no	
				S.WATANABE	7/28/08		sheet 7 of 8 size	
				enrg	7/28/08		62453	
				chr	7/28/08		A3	
				appd	7/28/08		type	
						Product Customer Drawing		Rev.
								E

sheet index	revision sheet																		
-------------	----------------	--	--	--	--	--	--	--	--	--	--	--	--	--	--	--	--	--	--

PRODUCT NO.	REMARKS
62453-622LF	WITHOUT METAL PLATE(M2 SCREWS)

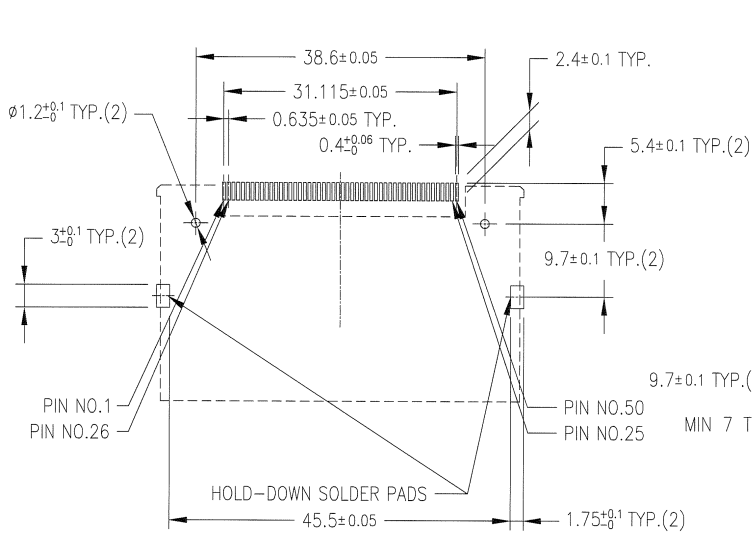

RECOMMENDED P.C.B. LAYOUT

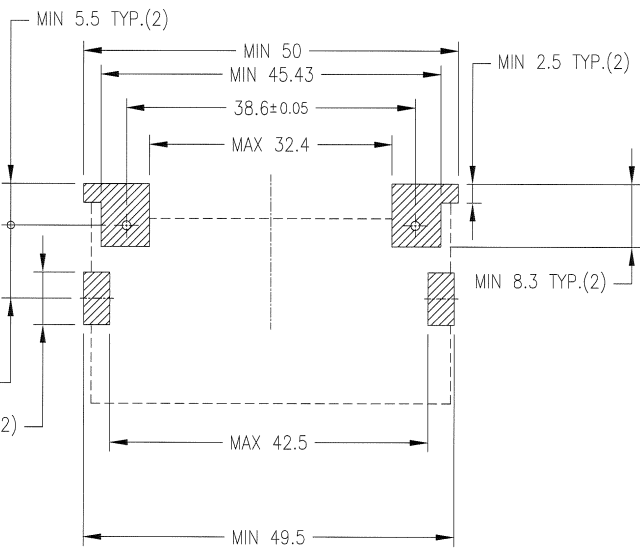

COMPONENT REFLOW KEEP OUT ZONE

NOTE
 1.PRODUCT SPECIFICATION : 110-404
 2.PACKAGING SPECIFICATION : GES-14-620
 3.SOLDER TAIL CO-PLANARITY : MAX 0.1
 4.FOR LEAD FREE P/N, THE PRODUCT MEETS EUROPEAN UNION DIRECTIVES AND OTHER COUNTRY REGULATIONS AS DESCRIBED IN GS-22-008.
 5.THE HOUSING WILL WITHSTAND EXPOSURE TO 260°C PEAK TEMPERATURE FOR 10 SECONDS IN A CONVENTION, INTRA-RED OR VAPOR PHASE REFLOW OVEN.
 6.MEASURED AT THE BOTTOM.

mat'l. code				surface		tolerance	projection	product family	CODE
---				ISO 1302	ISO 406	ISO 1101	mm	5AZF - CF HEADER	JP
ltr	description	ecm no	dr	date	tolerances unless otherwise specified		mm	title	
A	RELEASED	J05-0357	M.H	6/16/06	angles	linear	0.X	COMPACT FLASH HDR	
B	REVISED	J05-0748	R.S	10/31/06	0±2'	0.XXX	±0.3	TOP MOUNT	
C	REVISED	J06-0315	R.S	8/1/06		0.XXX	±0.3	scale 2:1	
D	REVISED	J06-0399	R.S	10/20/06	dr	S.WATANABE	7/28/08	dwg no	
E	REVISED	J06-0316	S.W	7/28/08	enrg	S.WATANABE	7/28/08	sheet 8 of 8	size
					chr	S.WATANABE	2008-7-29	62453	A3
					appd	S.WATANABE	2008-7-29	type Product Customer Drawing	
sheet	revision							Rev.	
index	sheet							E	