

PRODUCT NO.
SEE SHEET 4

REVISIONS			
REV	DESCRIPTION	ECN	BY DATE
1	SKETCHED		K.S 11/27/98
A	RELEASED	J90295	M.F 8/17/99

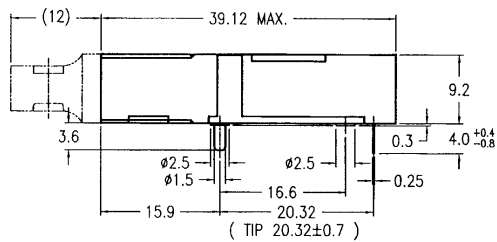
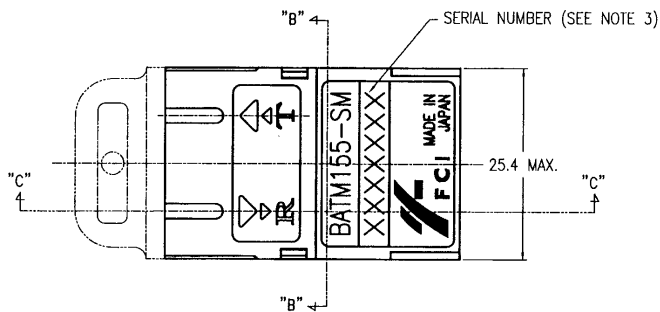
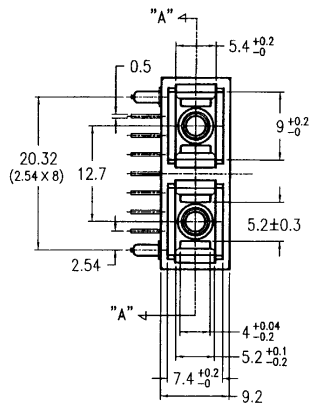

SHEET INDEX	ISSUE	A	A	A	A										
	SH NO.	1	2	3	4										
TOLERANCES UNLESS OTHERWISE SPECIFIED		MAT				DR	J. Ono	DATE	8/17/99	CUSTOMER COPY					
±0.3		SEE SHEET 2				ENGR	M. Fukuda	8/17/99	THIRD ANGLE PROJ						
LINEAR		FINISH				CHK	J. Okunuki	8/17/99	UNIT	MM					
ANGLES		±2°				APPD	K. Sugita	8/17/99	MM	INCH					

Electronics
FCI
FRAMATOME GROUP

TITLE: ATM155Mbps SM TRANSCEIVER
BATM155 - SM

SCALE: 2/1 SIZE: B DWG. NO.: 62060 REV: A SHEET: 1 of 4

DO NOT SCALE PRINT THIS INFORMATION IS CONFIDENTIAL AND IS DISCLOSED TO YOU ON CONDITION THAT NO FURTHER DISCLOSURE IS MADE BY YOU TO OTHER THAN BERG PERSONNEL WITHOUT WRITTEN AUTHORIZATION FROM BERG ELECTRONICS JAPAN K.K.

PDM: Rev:A STATUS: Released Printed: Sep 11, 2002

PRODUCT NO.
SEE SHEET 4

REVISIONS				
REV	DESCRIPTION	ECN	BY	DATE
1	SKETCHED		K.S	11/27/98
A	RELEASED	J90295	M.F	8/17/99

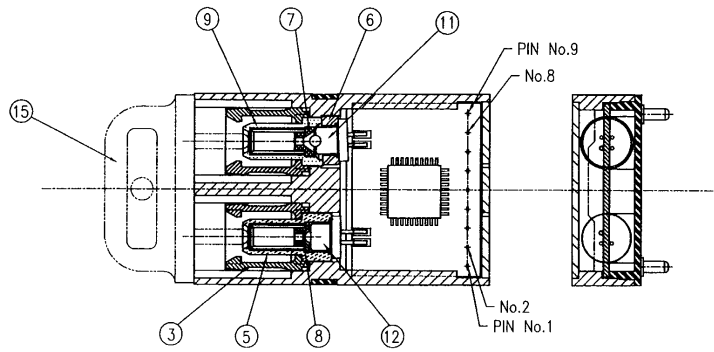

15	DUST CAP	1	RUBBER	
14	HYBRID IC	1		
13	SLEEVE	2	ZIRCONIA	SPLIT TYPE
12	PD	1		
11	LD	1		
10	PIN	2	CUPPER ALLOY	WITH Sn PLATING
9	SLEEVE GUIDE (LD)	1	STAINLESS STEEL	
8	STOPPER (PD)	1	STAINLESS STEEL	
7	STOPPER (LD)	1	STAINLESS STEEL	
6	LD RING	1	STAINLESS STEEL	
5	SLEEVE GUIDE (RD)	1	STAINLESS STEEL	
4	CASE	1	PLASTICS	
3	LATCH	2	PLASTICS	
2	COVER	1	PLASTICS	WITH LABEL
1	HOUSING	1	PLASTICS	
Part No.	NAME	QTY	MATERIAL	REMARKS

SHEET INDEX	ISSUE SH NO.	MAT	DR	DATE	CUSTOMER COPY
		SEE TABLE	<i>T. Ono</i>	8/17/99	
			ENGR <i>M. Fukuda</i>	8/17/99	
			CHK <i>J. Okawara</i>	8/17/99	
			APPR <i>K. Sasaki</i>	8/17/99	

 Electronics FCI FRAMATOME GROUP	
TITLE	
ATM155Mbps SM TRANSCEIVER BATM155 - SM	
SCALE	SIZE
2/1	B
DWG. NO.	REV
62060	A
SHEET	
20F	

DO NOT SCALE PRINT THIS INFORMATION IS CONFIDENTIAL AND IS DISCLOSED TO YOU ON CONDITION THAT NO FURTHER DISCLOSURE IS MADE BY YOU TO OTHER THAN BERG PERSONNEL WITHOUT WRITTEN AUTHORIZATION FROM BERG ELECTRONICS JAPAN K.K.

PDM: Rev:A STATUS: Released Printed: Sep 11, 2002

PRODUCT NO.
SEE SHEET 4

REVISIONS				
REV	DESCRIPTION	ECN	BY	DATE
1	SKETCHED		K.S	11/27/98
A	RELEASED	J90295	M.F	8/17/99

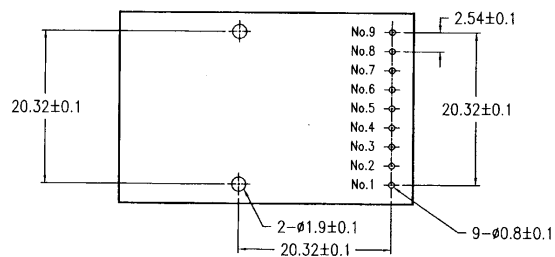

RECOMMENDED HOLE PATTERN

NOTE

1. PIN DIAGRAM

PIN No.	ASSIGN
1	Vee Rx
2	RD +
3	RD -
4	SD
5	Vcc Rx
6	Vcc Tx
7	TD -
8	TD +
9	Vee Tx

2. OPTICAL INTERFACE

SC DUPLEX RECEPTACLE

3. LABEL SHOWS SERIAL No.

XX XXXXX

— SERIAL No.
— MANUFACTURING YEAR

4. PRODUCT No. TO BE DIFFERENT BY ORDER.
TO SEE SHEET 4.

5. PRODUCT SPEC : No.130-078.

SHEET INDEX	ISSUE	SH NO.	MAT	DR	DATE	CUSTOMER COPY
			—	<i>J. Ono</i>	8/17/99	
				<i>M. Fukuda</i>	8/17/99	
				<i>Y. Okumura</i>	8/17/99	
				<i>K. Sasaki</i>	8/17/99	

		TITLE	
		ATM155Mbps SM TRANSCEIVER BATM155 - SM	
SCALE	SIZE	DWG. NO.	REV SHEET
2/1	B	62060	A 3of

DO NOT SCALE PRINT THIS INFORMATION IS CONFIDENTIAL AND IS DISCLOSED TO YOU ON CONDITION THAT NO FURTHER DISCLOSURE IS MADE BY YOU TO OTHER THAN BERG PERSONNEL WITHOUT WRITTEN AUTHORIZATION FROM BERG ELECTRONICS JAPAN K.K.

REVISIONS				
REV	DESCRIPTION	ECN	BY	DATE
1	SKETCHED		K.S	11/27/98
A	RELEASED	J90295	M.F	8/17/99

ORDERING SYSTEM

PRODUCT No.	ORDER QTY.
62060-001	$x < 1000$ pcs
62060-010	$1000 \leq x < 3000$ pcs
62060-030	$3000 \leq x < 5000$ pcs
62060-050	$5000 \leq x < 10000$ pcs
62060-100	$10000 \leq x$ pcs

SHEET INDEX	ISSUE SH NO.										
TOLERANCES UNLESS OTHERWISE SPECIFIED		MAT	DR	DATE	CUSTOMER COPY	TITLE					
LINEAR		—H—	<i>S. Ono</i>	8/17/99	<input type="checkbox"/>	ATM155Mbps SM TRANSCEIVER BATM155 - SM					
ANGLES		—H—	ENGR	8/17/99	<input checked="" type="checkbox"/>	THIRD ANGLE PROJ	SCALE	SIZE	DWG. NO.	REV	SHEET
			CHK	8/17/99	<input type="checkbox"/>		4/1	B	62060	A	4 of
			APPD	8/17/99		UNIT	MM				
							INCH				

DO NOT SCALE PRINT THIS INFORMATION IS CONFIDENTIAL AND IS DISCLOSED TO YOU ON CONDITION THAT NO FURTHER DISCLOSURE IS MADE BY YOU TO OTHER THAN BERG PERSONNEL WITHOUT WRITTEN AUTHORIZATION FROM BERG ELECTRONICS JAPAN K.K.

