

Tous droits strictement réservés. Toute réimpression, sans autorisation écrite du propriétaire, est formellement interdite.
 All rights strictly reserved. Reproduction or communication of this document, without written authority from the proprietor, is strictly prohibited.
 Copyright BERG ELECTRONICS by

All rights strictly reserved. Reproduction or issue to third parties in any form without written authority from the proprietor, is strictly prohibited.
 Copyright BERG ELECTRONICS by

PRODUCT NO.
61572-100CA/100CALF

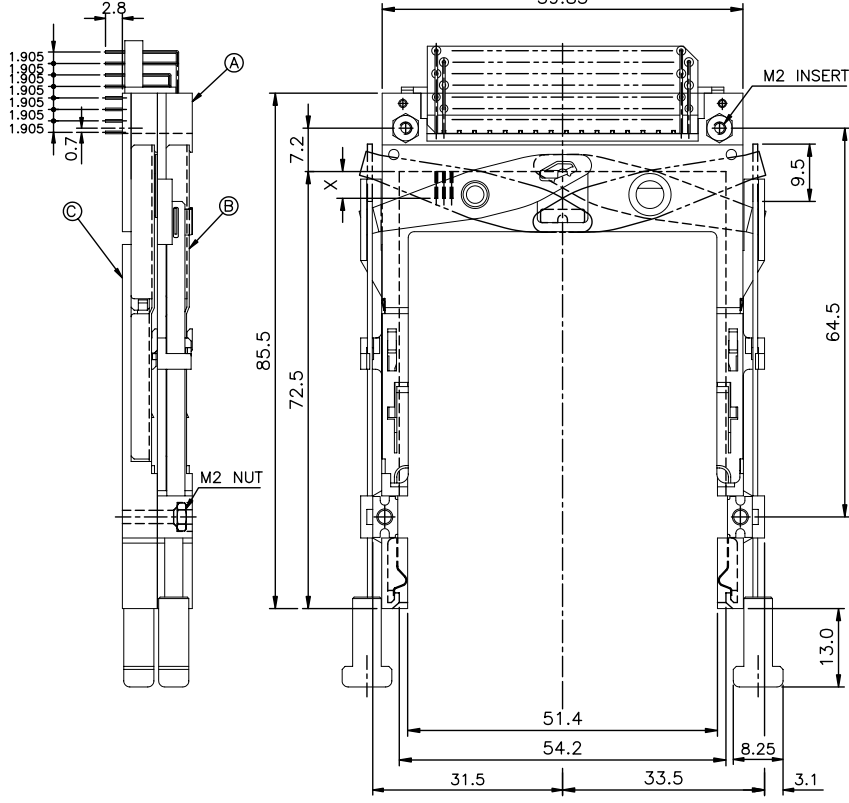

- NOTES:
- EJECT FORCE : 3.5 Kg MAX.
 - EJECT TRAVEL: 8.0mm
 - MATERIAL
 - PART A (HEADER ASS'Y)
 PLASTIC : HOUSING ...LCP UL94V-O BLACK
 LOCATOR ...G.F. 6/6 NYLON UL94-VO BLACK
 PIN : PHOSPHOR BRONZE
 - PART B AND C (EJECT MECHANISM ASS'Y)
 PLASTIC : GUIDE: POLYPHTHARAMID UL94V-O BLACK
 PUSH ROD: POLYPHTHARAMID UL94V-O BLACK
 PLATE : STAINLESS
 EMI CONTACT: PHOSPHOR BRONZE
 - FINISH (PIN)
 UNDER PLATING : 0.5µm MIN. Ni
 CONTACT AREA : 0.1µm MIN. GOLD OVER 0.5µm MIN. Pd-Ni
 SOLDER TAIL (TIN LEAD OPTION): 2.5µm MIN. Sn-Pb
 SOLDER TAIL (LEAD FREE OPTION): 2.5µm MIN. PURE TIN

DIM "X"	4.25±0.1	3.5±0.1	5.0±0.1
OTHERS	36,67	1,17,34,35,51,68	

- IF LEAD FREE P/N THE HOUSING WILL WITHSTAND EXPOSURE TO 260°C PEAK TEMPERATURE FOR 10 SECONDS IN A WAVE SOLDER APPLICATION WITH A 1.00MM MINIMUM THICK CIRCUIT BOARD.
- IF LEAD FREE P/N THE PRODUCT MEETS EUROPEAN UNION DIRECTIVES AND OTHER COUNTRY REGULATIONS AS DESCRIBED IN GS-22-008
- LEAD FREE P/N PACKAGING MEETS GS-14-920 SPECIFICATION

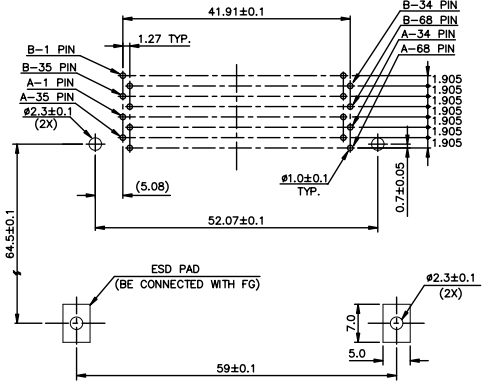

4 CARD INSERTION DIRECTION

USE THE FOLLOWING P/N FOR OFFICIAL ORDERING

C	EJECT MECH ASS'Y	61571-00CA
B	EJECT MECH ASS'Y	95627-10CA
A	HDR ASS'Y	92821-000/000LF
	DESCRIPTION	P/N

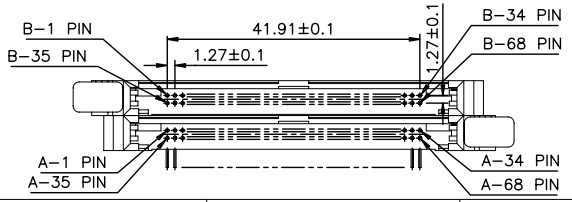

mat'l code		tolerance unless otherwise specified		CUSTOMER COPY	FCI ELECTRONICS	
rev.	ecn no.	dr	date	linear	projection	title
A	T60411	L S	08/30/96	±0.30	1	NARROW BODY FRONT EJECT
B	T70019	W L	01/07/97		2	TYPE 1/2/3 EJECTOR ASS'Y
C	T90279	W L	07/23/99	angles ± 2°	3	
D	N05-0059	W B	03/03/08		4	
				dr SHIRLEY HSU 08/30/96	unit	product family : PCMCIA
				enrg JOSEPH HSIA 08/30/96	mm/inch	size
				chr JOSEPH HSIA 08/30/96	scale	dwg no.
				appd JENN TSAO 08/30/96	1.5:1	61572
sheet index	revision sheet	D	D	D		code
		1	2	3		TWN
						sheet
						1 of 3

Tous droits strictement réservés. Reproduction ou communication sans autorisation écrite du propriétaire.
 Property of BERG ELECTRONICS. Written authority from the proprietor.
 Copyright BERG ELECTRONICS by

All rights strictly reserved. Reproduction or issue to third parties in any form without the written authority of BERG ELECTRONICS.
 Property of BERG ELECTRONICS. Written authority from the proprietor.
 Copyright BERG ELECTRONICS by

PRODUCT NO.
61572-200CA/200CALF

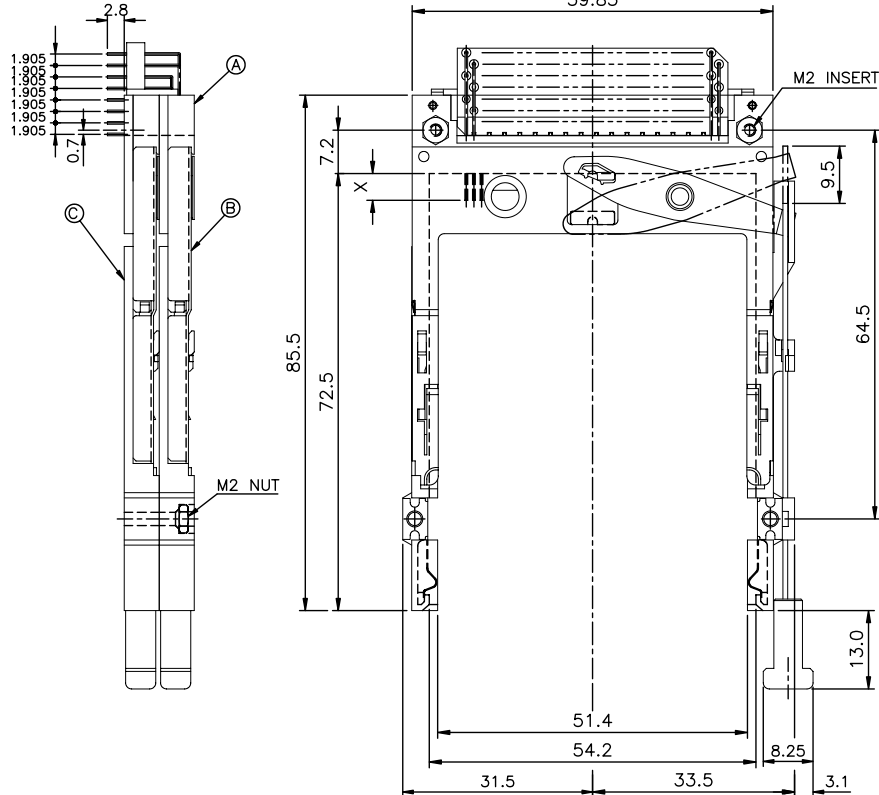

NOTES:

- EJECT FORCE : 3.5 Kg MAX.
- EJECT TRAVEL: 8.0mm
- MATERIAL
 - PART (A) (HEADER ASS'Y)
PLASTIC : HOUSING ...LCP UL94V-0 BLACK
LOCATOR ...G.F. 6/6 NYLON UL94-VO BLACK
PIN : PHOSPHOR BRONZE
 - PART (B) AND (C) (EJECT MECHANISM ASS'Y)
PLASTIC : GUIDE: POLYPHTHARAMID UL94V-0 BLACK
PUSH ROD: POLYPHTHARAMID UL94V-0 BLACK
PLATE : STAINLESS
EMI CONTACT: PHOSPHOR BRONZE
- FINISH (PIN)
UNDER PLATING : 0.5µm MIN. Ni
CONTACT AREA : 0.1µm MIN. GOLD OVER 0.5µm MIN. Pd-Ni
SOLDER TAIL (TIN LEAD OPTION): 2.5µm MIN. Sn-Pb
SOLDER TAIL (LEAD FREE OPTION): 2.5µm MIN. PURE TIN
- DIM "X"

4.25±0.1	3.5±0.1	5.0±0.1
OTHERS	36,67	1,17,34,35,51,68
- IF LEAD FREE P/N THE HOUSING WILL WITHSTAND EXPOSURE TO 260°C PEAK TEMPERATURE FOR 10 SECONDS IN A WAVE SOLDER APPLICATION WITH A 1.00MM MINIMUM THICK CIRCUIT BOARD.
- IF LEAD FREE P/N THE PRODUCT MEETS EUROPEAN UNION DIRECTIVES AND OTHER COUNTRY REGULATIONS AS DESCRIBED IN GS-22-008
- LEAD FREE P/N PACKAGING MEETS GS-14-920 SPECIFICATION

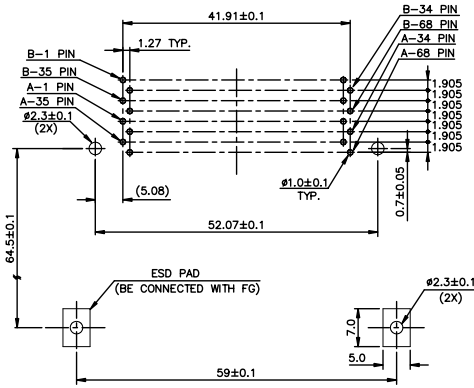

4 CARD INSERTION DIRECTION

USE THE FOLLOWING P/N FOR OFFICIAL ORDERING

(C)	EJECT MECH ASS'Y	61571-00CA
(B)	EJECT MECH ASS'Y	95627-00CA
(A)	HDR ASS'Y	92821-000/000LF
	DESCRIPTION	P/N

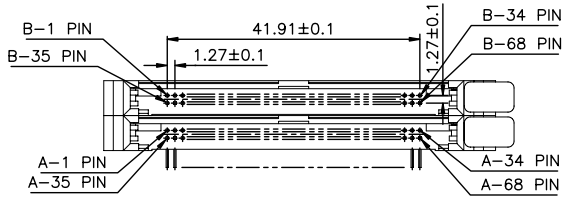

mat'l code	tolerance unless otherwise specified	CUSTOMER COPY	BERG ELECTRONICS	
rev. D	linear ±0.30	projection	FCI	
	angles ± 2°	unit	title	
	dr WENDY CHEN 01/07/97	mm/inch	NARROW BODY FRONT EJECT	
	enrg JOSEPH HSIA 01/07/97	scale	TYPE 1/2/3 EJECTOR ASS'Y	
	chr JOSEPH HSIA 01/07/97	1.5:1	product family : PCMCIA	code
	appd JENN TSAO 01/07/97		size dwg no.	TWN
sheet index	revision sheet		A3	61572
				sheet 2 of

PDM: Rev:D STATUS Released Printed: Oct 12, 2010

PRODUCT NO.
61572-300CA/300CALF

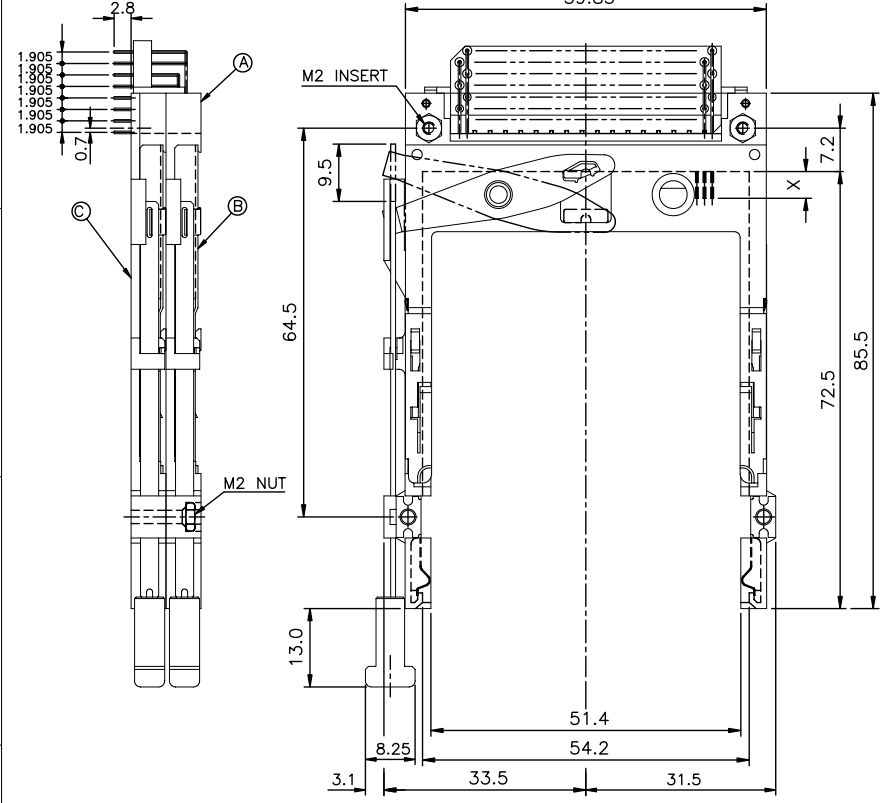

- NOTES:
- EJECT FORCE : 3.5 Kg MAX.
 - EJECT TRAVEL: 8.0mm
 - MATERIAL
 - PART A (HEADER ASS'Y)
PLASTIC : HOUSING ...LCP UL94V-0 BLACK
LOCATOR ...G.F. 6/6 NYLON UL94-VO BLACK
PIN : PHOSPHOR BRONZE
 - PART B AND C (EJECT MECHANISM ASS'Y)
PLASTIC : GUIDE: POLYPHTHARAMID UL94V-0 BLACK
PUSH ROD: POLYPHTHARAMID UL94V-0 BLACK
PLATE : STAINLESS
EMI CONTACT: PHOSPHOR BRONZE
 - FINISH (PIN)
UNDER PLATING : 0.5µm MIN. Ni
CONTACT AREA : 0.1µm MIN. GOLD OVER 0.5µm MIN. Pd-Ni
SOLDER TAIL (TIN LEAD OPTION): 2.5µm MIN. Sn-Pb
SOLDER TAIL (LEAD FREE OPTION): 2.5µm MIN. PURE TIN

DIM "X"	4.25±0.1	3.5±0.1	5.0±0.1
OTHERS	36,67	1,17,34,35,51,68	

- IF LEAD FREE P/N THE HOUSING WILL WITHSTAND EXPOSURE TO 260°C PEAK TEMPERATURE FOR 10 SECONDS IN A WAVE SOLDER APPLICATION WITH A 1.00MM THICK CIRCUIT BOARD.
- IF LEAD FREE P/N THE PRODUCT MEETS EUROPEAN UNION DIRECTIVES AND OTHER COUNTRY REGULATIONS AS DESCRIBED IN GS-22-008
- LEAD FREE P/N PACKAGING MEETS GS-14-920 SPECIFICATION

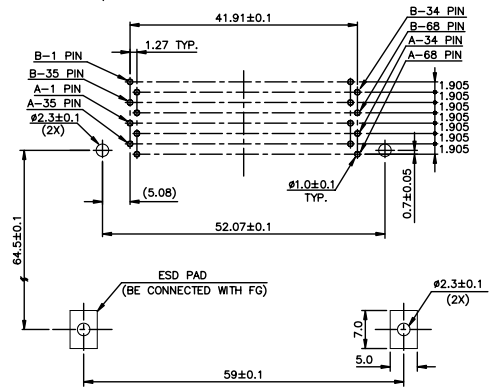

4 CARD INSERTION DIRECTION

USE THE FOLLOWING P/N FOR OFFICIAL ORDERING

© EJECT MECH ASS'Y	61571-10CA
ⓑ EJECT MECH ASS'Y	95627-10CA
Ⓐ HDR ASS'Y	92821-000/000LF
DESCRIPTION	P/N

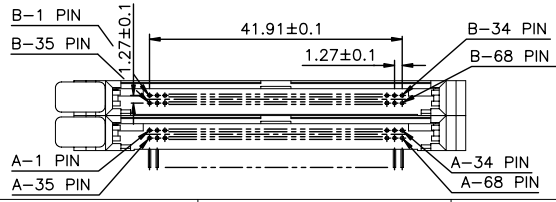

mat'l code	tolerance unless otherwise specified	CUSTOMER COPY	ELECTRONICS	
rev. ecn no. dr date	linear ±0.30	projection	FCI	
	angles ± 2°	unit	title	
dr WENDY CHEN 07/22/99		mm/inch	NARROW BODY FRONT EJECT TYPE 1/2/3 EJECTOR ASS'Y	
enrg JOSEPH HSIA 07/22/99		scale	product family : PCMCIA	code
chr JOSEPH HSIA 07/22/99		1.5:1	size dwg no.	TWN
appd LELAND WANG 07/22/99			61572	sheet 3 of 3
sheet index	revision sheet			