

**Operating Positions**

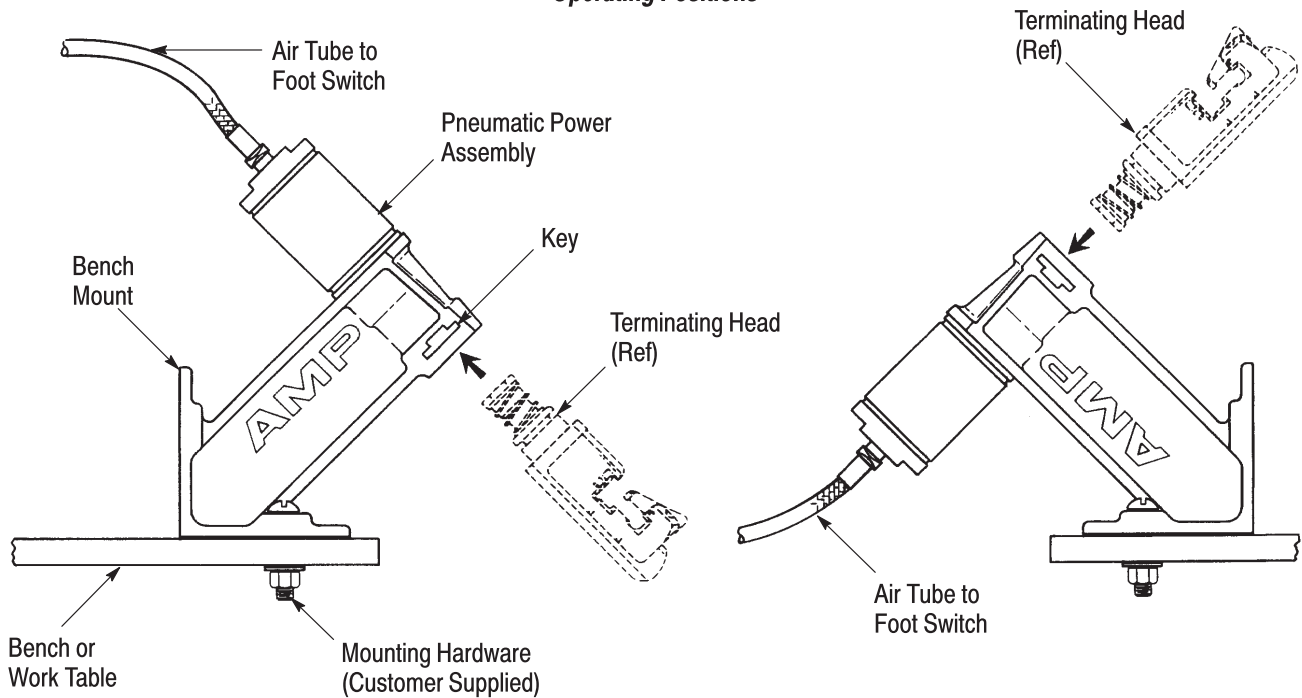

Figure 1

**1. INTRODUCTION**

Pneumatic Power Bench Assembly 58338-1 is a pneumatic power unit designed to accept a variety of interchangeable terminating heads or feed track assemblies that terminate stripped wire in connectors.

Refer to the instructions packaged with the terminating head or feed track assembly for proper selection, setup and adjustment procedures, terminating and test procedures, and maintenance. Read this and all referenced materials carefully before using the power bench assembly.

**NOTE** All numerical values in this instruction sheet are in metric units [with U.S. customary units in brackets]. Figures are not drawn to scale.

Reasons for reissue of this instruction sheet are provided in Section 7, REVISION SUMMARY.

**2. DESCRIPTION** (See Figure 1)

The power bench assembly consists of a bench mount with an attached pneumatic power assembly, a foot switch, and air tubes which connect the foot

switch to the power assembly and the air source to the foot switch.

The bench mount is attached to a bench or work table with screws or clamps and the foot switch is used to actuate the power assembly when connected to an air source.

In this use, the pneumatic power bench assembly emits less than 70 dB.

**3. INSTALLATION**

The bench mount is designed to be mounted in either of the two positions shown in Figure 1. Orientation of the bench mount depends on operator preference and the desired eject direction of terminated connector (refer to Figure 2). Install the bench mount as follows:

1. Place the bench mount on a bench or work table in the desired location and orientation.
2. Mark the location for the screws in the bench surface through the drilled holes of the bench mount flange. Drill holes for the mounting screws.

**NOTE** Mounting hardware is not supplied with the power bench assembly and must be supplied by the customer.

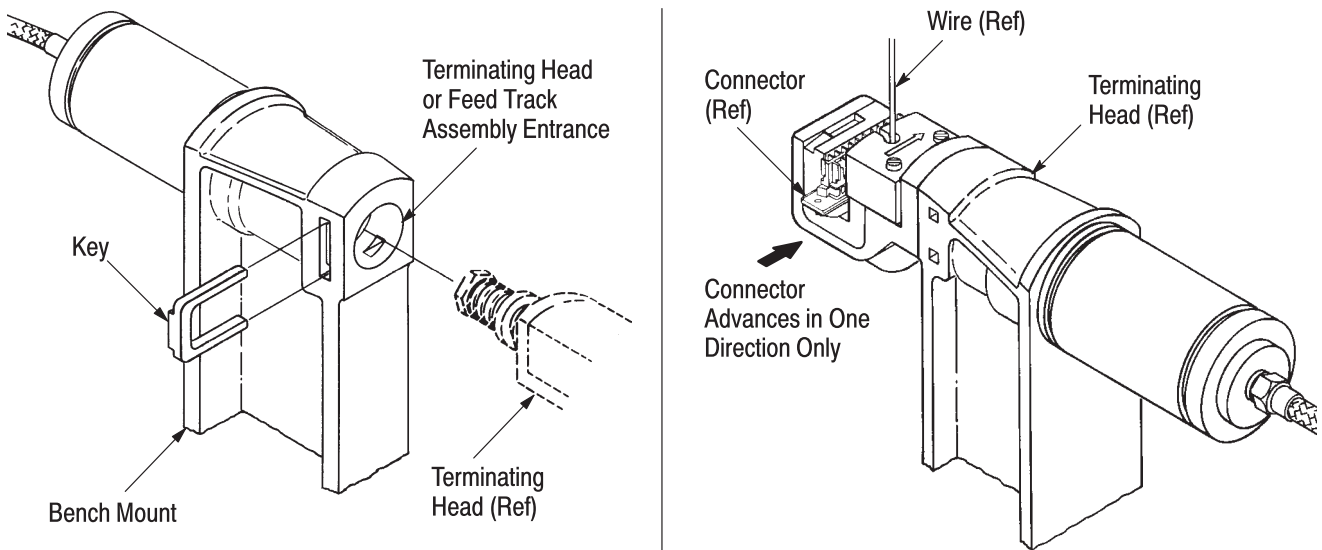



Figure 2

3. Secure the screws.
4. Connect the air tube to an approved air source. It is recommended that a filter–regulator–lubricator unit with the lubricator adjusted to the minimum setting be used with the power bench assembly. Refer to Figure 3.

**NOTE**  The power assembly is designed to operate at an air pressure range of 276 through 483 kPa [40 through 70 psi]. Service life of the power assembly can be greatly extended when only the necessary air pressure is applied. Excessive pressure causes unnecessary wear and strain on the power assembly, terminating head or feed track assembly, and connectors.

**4. INSTALLATION AND REMOVAL OF TERMINATING HEAD OR FEED TRACK ASSEMBLY**

1. DISCONNECT the power bench assembly from the air supply.

**DANGER**  To avoid personal injury, ALWAYS DISCONNECT the power bench assembly from the air supply when installing or removing the terminating head or feed track assembly.

2. Position the blade tip of a screwdriver between the shoulder of the key and the power assembly body. Gently pry the key out of the keyway.
3. Insert the terminating head or feed track assembly into the head entrance of the power assembly body until it bottoms. See Figure 2.
4. Insert the key completely into the keyway to retain the terminating head or feed track assembly.

5. To remove the terminating head or feed track assembly, disconnect the power bench assembly from air supply, remove the key, and pull the terminating head or feed track assembly out of the power assembly. Refer to Figure 2.

**5. MAINTENANCE AND INSPECTION**

**DANGER**  To avoid personal injury, ALWAYS DISCONNECT the power bench assembly from the air supply when performing maintenance or inspection procedures.

These procedures have been established to ensure the quality and reliability of the power bench assembly. A brief inspection should be made daily by the operator and a more detailed inspection should be performed on a scheduled basis by quality control personnel.

**5.1. Daily Maintenance**

Each operator of the unit should be made aware of, and responsible for, the following procedures:

1. Remove dust, moisture, and other contaminants with a clean, soft brush, or clean, lint-free cloth. DO NOT use objects that could damage the power bench assembly.
2. Ensure that all components are in place and properly secured.
3. With the terminating head or feed track assembly in place, connect the air supply and actuate the power assembly by depressing and releasing the foot switch to ensure that the mechanisms and plunger move smoothly and freely.

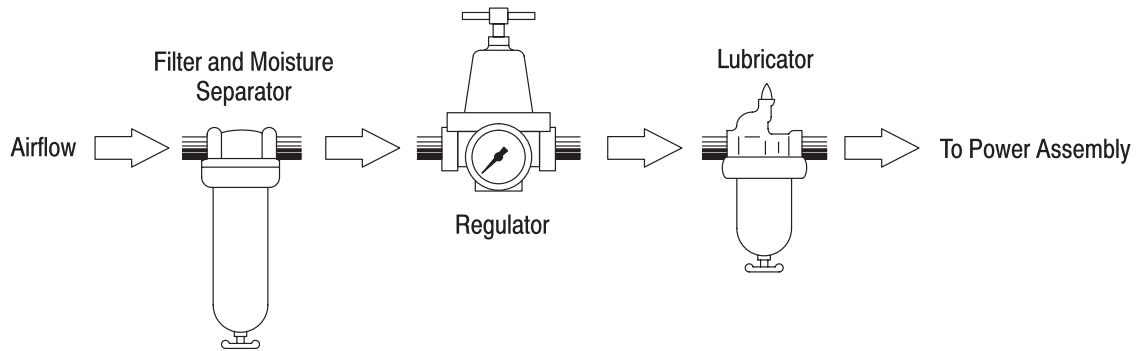

Figure 3

## 5.2. Periodic Inspection

Regular inspections should be performed by quality control personnel. A record of quality control inspections should remain with the power bench assembly or with personnel responsible for the assembly. It is recommended that one inspection per month be performed; however, operator training and skill, amount of use, working conditions, and established company standards are all factors to be considered in scheduling inspections.

The inspections should be performed in the following sequence:

1. Remove any accumulated film with a suitable cleaning agent that will not affect plastic material.
2. Make certain that all components are in place and properly secured. Check air tube fittings for leaks.
3. Make a few test terminations and inspect the terminations in accordance with the inspection procedure described in the instructions packaged with the terminating head or feed track assembly.
4. Check for chipped, cracked, worn, or broken areas. If damage is evident, repair is necessary. See Section 6, REPLACEMENT AND REPAIR.

## 6. REPLACEMENT AND REPAIR

Customer-replaceable parts are listed in Figure 4. A complete inventory should be stocked and controlled to prevent lost time when replacement of parts is necessary. Parts other than those listed should be replaced by Tyco Electronics Corporation to ensure quality and reliability. Order replacement parts through your representative, or call 1-800-526-5142, or send a facsimile of your purchase order to 717-986-7605, or write to:

CUSTOMER SERVICE (038-035)  
 TYCO ELECTRONICS CORPORATION  
 PO BOX 3608  
 HARRISBURG PA 17105-3608

or

TYCO ELECTRONICS CORPORATION UK LTD  
 BARTON TORS  
 BIDEFORD  
 NORTH DEVON, GREAT BRITAIN

For customer repair service, call 1-800-526-5136.

## 7. REVISION SUMMARY

Revisions to this instruction sheet include:

- Updated document to corporate requirements
- Replaced address for customer repair service with phone number
- Replaced part number for Item 7 in Figure 4

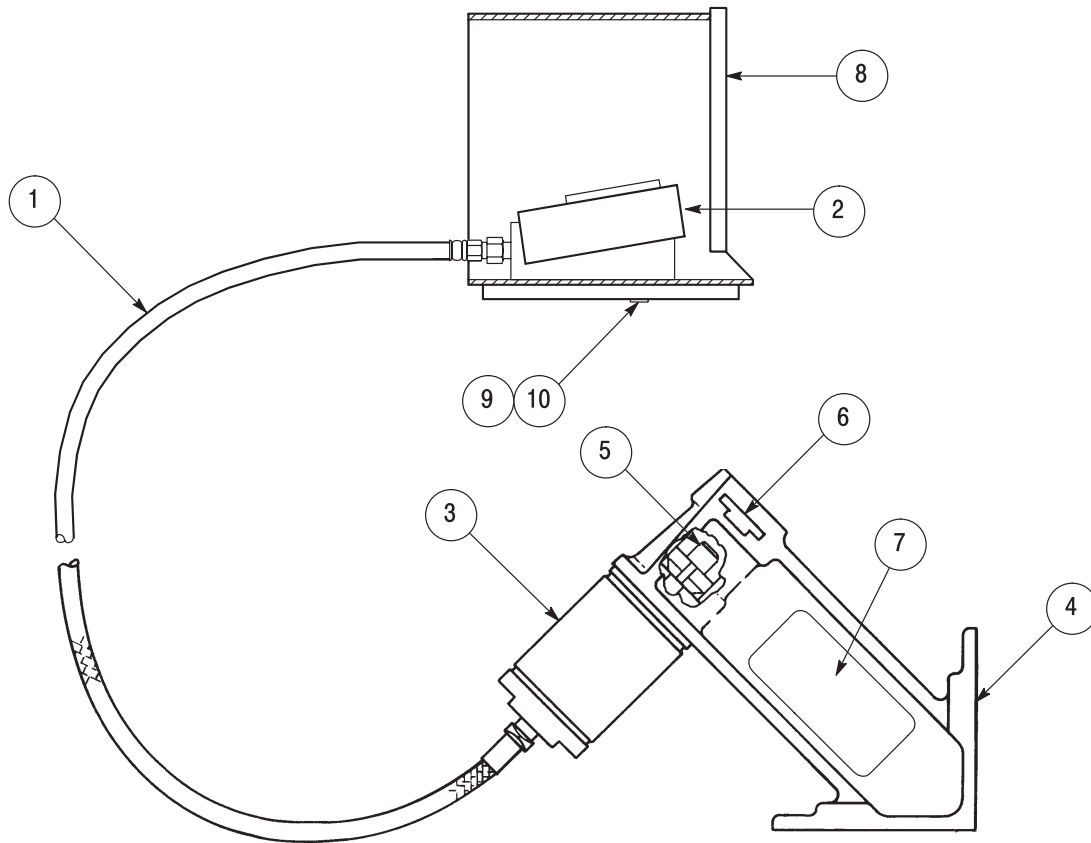

REPLACEABLE PARTS			
ITEM	PART NUMBER	DESCRIPTION	QTY PER ASSEMBLY
1	312622-2	SUBASSEMBLY, Air Tube	2
2	24198-1	AIR VALVE, 3-Way	1
3	313874-1	AIR CYLINDER	1
4	313852-1	BENCH MOUNT	1
5	312141-1	NUT, Cam Adjustment	1
6	312140-1	KEY	1
7	217915-1	LABEL, CE	1
8	453866-1	GUARD, Foot Switch	1
9	4-23715-1	SCREW, Machine Pan Head, 4-40 × .19 in.	1
10	21060-7	SCREW, Slotted Pan Head, 4-40 × .25 in.	1

Figure 4