

This document is the property of Amphenol Corporation and is delivered on the express condition that it is not to be distributed, reproduced or used, in whole or in part, for manufacture or sale by anyone other than Amphenol Corporation without its prior consent, & that no right is granted to disclose or to use any information in this document.

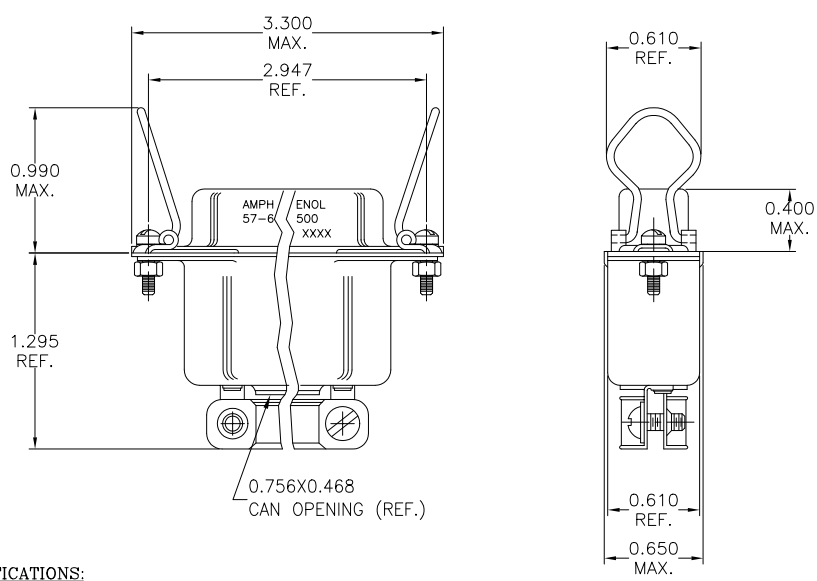

REVISIONS				
SYM	ECN	DESCRIPTION	DATE	APPROVED
A	HK	PRELIMINARY RELEASE	01/16/03	Y.M.LEE
B	HK	ADD CHOP OF ROHS	5/4/06	IP

TABLE 1

CONNECTOR SIZES	AVERAGE MATING FORCE (POUNDS)
14	5
24	8
36	12
50	15
64	19



SPECIFICATIONS:

- 1) SOLDER CUP CONTACT: TO ACCOMMODATE 22-30 AWG SOLID AND 24-30 STRANDED CONNECTOR WIRES.
- 2) DIELECTRIC: DIALYL-PHTHALATE PER MIL-M-14F TYPE MDG UL-94V0
- 3) CONTACT MATERIAL: COPPER ALLOY
- 4) CONTACT: 20 MICRO-INCHES MIN. GOLD MATING AREA: GOLD FLASH ON TAIL AREA. 50 MICRO-INCHES MIN. NICKEL UNDERPLATING ALL OVER.
- 5) SHELL MATERIAL: ZINC PLATED STEEL WITH CLEAR CHROMATE COATING
- 6) CURRENT CAPACITY: 5 AMPS/CONTACT
- 7) VOLTAGE RATING: 700 VOLTS D.C. AT SEA LEVEL
200 VOLTS D.C. AT 70,000 FEET
- 8) INSULATION RESISTANCE: >5000 M OHM
- 9) DIELECTRIC WITHSTANDING VOLTAGE: 1200 VAC (RMS) AT SEA LEVEL
- 10) CONNECTOR MATING FORCE: REFER TO TABLE 1.

- 11) CONTACT RETENTION FORCE: 2 LBS MAX.
- 12) DURABILITY: 250 CYCLES MIN.
- 13) VIBRATION: NO INTERRUPTIONS < 1u SEC.
- 14) OPERATING TEMPERATURE: -55°C TO +105°C (-67°F TO +221°F)

CUSTOMER INFORMATION DRAWING

ITEM NO	PART OR IDENTIFICATION NO	NOMENCLATURE OR DESCRIPTION	QTY REQ'D
PARTS LIST			
UNLESS OTHERWISE SPECIFIED TOLERANCES		APPROVAL	DATE
U.S. METRIC		DRAWN XS.GUO	5/4/08
.X +/- 0.020		CHECKED	
.XX +/- 0.010		CHECKED	
.XXX +/- 0.005			
FRACTIONS +/-			
ANGLES +/- 1°		DRAWING FILE :	
FOR MATERIALS AND FINISHES		\DRAWING\557\C5760500.DWG	
SEE NOTES		REMOVE SHARP EDGES	
DIMENSIONS		ANGLE OF PROJECTION	
U.S. INCHES			
-(METRIC)-		-	
		TITLE	
		50 CONTACT CABLE RECEPTACLE, ASSY WITH SPRING LATCH & MODIFIED BACK SHELL(MINI. RIBBON)	
		SIZE	REV.
		A3	B
		SCALE	SHEET 1 OF 1
		NONE	