

**PROPER USE GUIDELINES**

Cumulative Trauma Disorders can result from the prolonged use of manually powered hand tools. Hand tools are intended for occasional use and low volume applications. A wide selection of powered application equipment for extended-use, production operations is available.

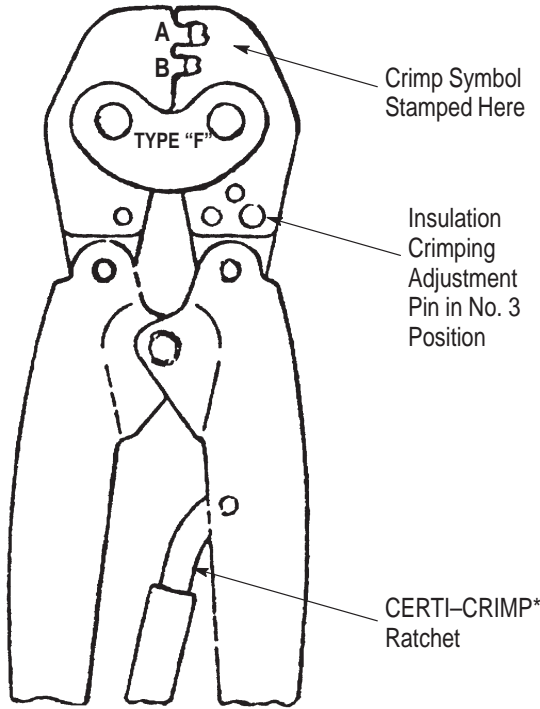

Figure 1

**1. INTRODUCTION**

Crimping tools 575937 and 575938 (See Figure 1) are used to crimp the MATE-N-LOK Terminals listed in

the table in Figure 2. Use Figure 2 to select the proper tool for the wire size to be used.

**NOTE** Dimensions in this instruction sheet are in millimeters [with inches in brackets]. Figures are for reference only and are not drawn to scale.

Reasons for reissue are provided in Section 5, REVISION SUMMARY.

**2. WIRE STRIPPING**

Strip the wire 5.2 [.200] for both the pin and socket terminals.

**3. INSULATION CRIMPING ADJUSTMENT**

1. The insulation crimping jaws have three adjustments.
2. Place the insulation crimping adjustment pin in the No. 3 position. See Figure 1.
3. Place the terminal in the tool according to Paragraph 4, and insert the unstripped wire into only the insulation barrel.
4. Crimp the terminal. Bend the wire back and forth once. If the wire pulls out, set pin in No. 2 position and repeat the test until the desired grip is obtained.

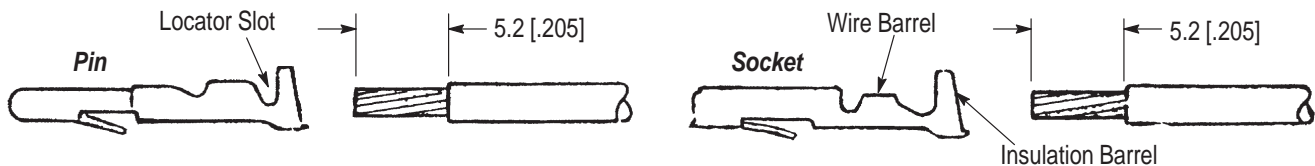

TOOL NUMBER	CRIMP SYMBOL	WIRE SIZE	INSULATION DIA.	TERMINAL NO.	TERMINAL H.P. NO.
575937	A	0.3-0.75 mm 000-1500 CMA	1.39-2.54 [.055-.100]	163240	163242
				163241	163243
	B	0.5-1.0 mm 1000-2000 CMA	1.65-2.79 [.065-.110]	160495	160565
				160496	160566
575938	A	1.0-1.5 mm 2000-3000 CMA	2.28-3.3 [.090-.130]	160497	160567
				160498	160568
	B	1.5-2.5 mm 3000-5000 CMA	2.54-3.8 [.110-.150]	160497	160567
				160498	160568

Figure 2

**4. CRIMPING PROCEDURE**

1. These tools is equipped with a CERTI-CRIMP Ratchet (see Figure 1) to ensure proper crimping. To open the tool handles, squeeze them until the ratchet releases.

**NOTE**

*Once the ratchet is engaged, the handles cannot be opened until they are fully closed.*

2. Place the terminal in the tool so that the locator fits in the slot between the terminal insulation barrel and the wire barrel. See Figure 3.

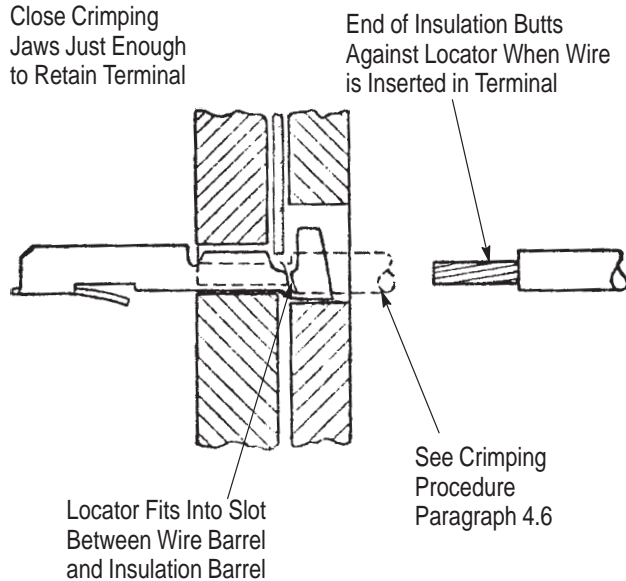

Figure 3

3. Close the handles until the crimping jaws close just enough to retain the terminal. See Figure 3.

**CAUTION**

*Do not deform the terminal. Damaged product should not be used. If damaged product is evident, it should be replace with a new one. Terminals should not be re-terminated.*

4. Insert the stripped wire into the terminal until the end of the insulation butts against the locator.

5. Close the tool handles until the CERTI-CRIMP Ratchet releases. Remove the crimped terminal from the tool.

6. For wire with insulation diameter 3.5 [.138] and larger, first insert the wire into the terminal. The insulation barrel will be fixed around the insulation.

7. Then follow steps 2 and 5.

**5. MAINTENANCE**

Lubricate all pins, pivot points, and bearing surfaces as needed with any good S.A.E. No. 2 Motor Oil.

**6. REVISION SUMMARY**

Revisions to this instruction sheet per EC 0990-1355-03 include:

- Updated document to corporate requirements
- Updated document to new format