

REV	DATE	DESCRIPTION	BY	CHK	APP
B	ADD:3/1, NPR 038-62 & EC 0502-0208-98 4-27-98		GG	SH	
C	REV-ECD-06-06535		20MP06	LH	SH
D	REV-ECD-06-07000		17.XAL36	LH	SH

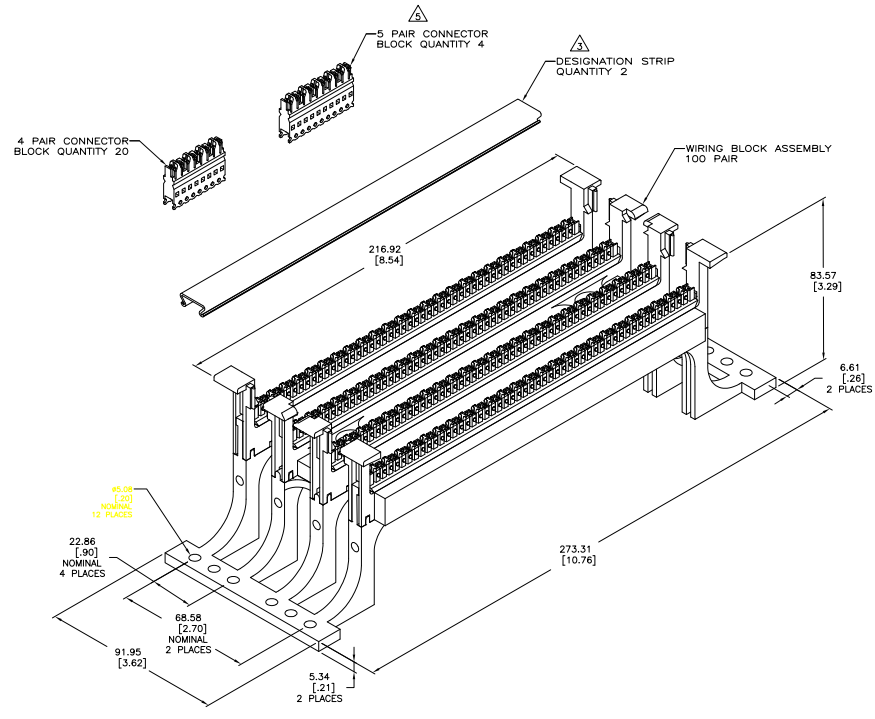

- △ DIMENSIONS ARE MAXIMUM UNLESS OTHERWISE SPECIFIED.
- △ MATERIAL: WIRING BLOCK ASSEMBLY AND CONNECTOR BLOCK- POLYCARBONATE MOLDING COMPOUND, FLAME RETARDANT, INOXY.
DESIGNATION STRIP- RIGID PVC, CLEAR.
TERMINALS- PHOSPHOR BRONZE PLATED WITH 3.81µm [.000150] MINIMUM MATTE-TIN OVER
1.27µm [.000050] MINIMUM NICKEL UNDERPLATE.
- △ WHITE, DESIGNATION STRIP LABEL NOT SHOWN, QUANTITY 2.
- 4. PACKAGE ONE KIT PER POLYBAG.
- △ THE ODD CONNECTING BLOCK IS TYPICALLY LOCATED ON THE RIGHT END.
- 6. LACING STRIPS MARKED BLACK EVERY FIFTH PAIR.
- △ SEE RESTRICTED CUSTOMER DRAWING 3-569439-1.

△
569439-1
PART NO.

THIS DRAWING IS A CONTROLLED DOCUMENT.		DATE: 11-29-98	BY: [Signature]	CHK: [Signature]	APP: [Signature]
DESIGNER: [Signature]	ENGINEER: [Signature]	DATE: 11-29-98	BY: [Signature]	CHK: [Signature]	APP: [Signature]
110 CROSS CONNECT KIT, 100 PAIR, WITH LEGS, 4 & 5 PAIR CONNECTOR BLOCK			SIZE: A1	DATE: 100779	DRAWING NO: G=569439
CUSTOMER DRAWING			SCALE: 1:1	SHEET: 1	TOTAL: 1