

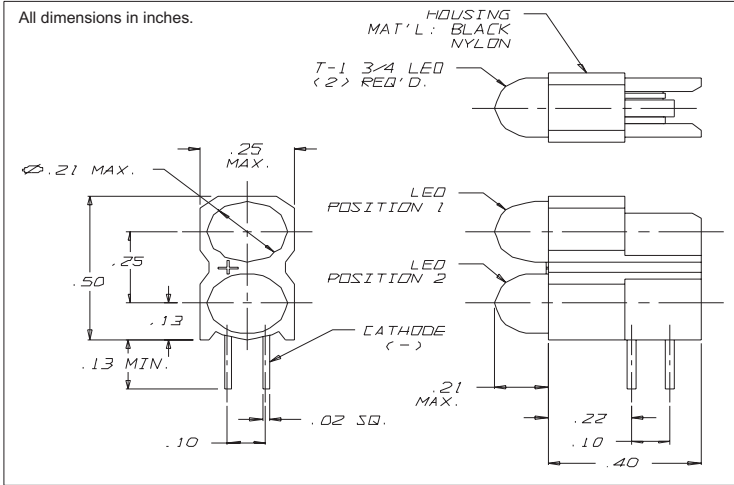

5670 Series T-1 3/4 Right Angle 2 High LED Assembly

DESCRIPTION AND FEATURES



Features:

- Dual block mounting allows 2 LEDs in same board area.
- Single block mounting-height and spacing alignment, saves assembly cost.
- Super Brite LEDs, high light output, diffused lens.
- Low current, only 2 mA needed.
- Built-in resistor chip operates off 5 volt supply without external resistor.
- Standoffs prevent flux entrapment.

Housing: Black Nylon, UL94V-O

Alternate LEDs are also available in this package as a standard variation.

Mounting hole pattern on page 1-X6.

ELECTRO-OPTICAL CHARACTERISTICS AND RATINGS

Part Number	Emitted Color	Typical Intensity (mcd)	Rated Current (mA)	Continuous Forward Current Max. (mA)	Forward Voltage		Reverse Breakdown Voltage Min.(V)	Peak Wavelength (nm)	Peak Forward Current @ 1ms-300pps (A)
					Typ. (V)	Max. (V)			
5670H1;1	Red/Red	6.3	10	35	60	3.0	5	650	1.0
5670H3;3	Amber/Amber	10.0	10	35	60	3.0	5	608	1.0
5670H5;5	Green/Green	10.0	10	35	60	3.0	5	563	.09
5670H7;7	Yellow/Yellow	6.3	10	35	60	3.0	5	585	1.0

LED Color	LED Code	Typical Intensity (mcd)	Rated Current (mA)	Forward Current Max. (mA)	Forward Voltage		Reverse Breakdown Voltage Min. (V)	Peak Wavelength (nm)
					Typ. (V)	Max. (V)		
Red	1LC	2.3	2.0	7	1.8	2.2	5	635
Green	5LC	2.3	2.0	7	1.8	2.2	5	565
Yellow	7LC	2.1	2.0	7	1.9	2.7	5	583
Red	1-5V	8.0	10.0	15	5.0	7.5	5	635
Amber	3-5V	8.0	10.0	15	5.0	7.5	5	583
Green	5-5V	8.0	12.0	15	5.0	7.5	5	565
Red	1	6.3	10.0	60	2.0	3.0	5	650
Amber	3	10	10.0	60	2.0	3.0	5	608
Green	5	10	10.0	60	2.2	3.0	5	563
Yellow	7	6.3	10.0	60	2.1	3.0	5	585

147 Central Avenue
Hackensack, NJ 07601
Phone: (201) 489-8989
Fax: (201) 489-6911

18703 Dix Toledo Road
Brownstown, MI 48193

Saret Zone Franca, Edificio B
Alajuela Costa Rica

E-mail:sales@chml.com • Web Site: www.chml.com

Chicago Miniature Lighting, LLC reserves the right to make specification revisions that enhance the design and/or performance of the product