

4

3

2

1

THIS DRAWING IS UNPUBLISHED. RELEASED FOR PUBLICATION 2000
 © COPYRIGHT 2000 BY TYCO ELECTRONICS CORPORATION. ALL RIGHTS RESERVED.

LOC	DIST	REVISIONS			
P	LTR	DESCRIPTION	DATE	DWN	APVD
A1	-	SEE SHEET 1	-	-	-

CONTROL DIMENSIONS AFTER ASSEMBLY

KONTROLLMASSE NACH MONTAGE

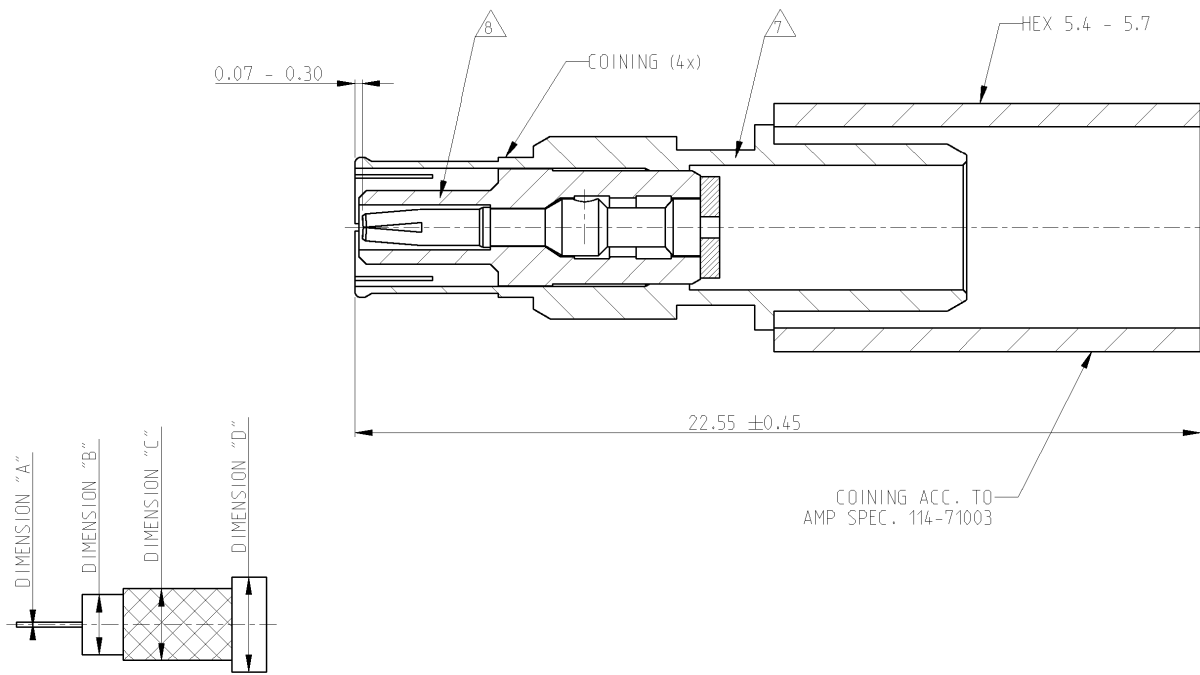

COINING ACC. TO AMP SPEC. 114-71003

120 OHMS CABLE THAT SUITS TO THIS PN:

- A: ONE WIRE $\varnothing 0.25 \pm 0.02$
- B: $\varnothing 3.1 + 0.05 - 0.1$
- C: $\varnothing 3.7 \pm 0.1$
- D: $\varnothing 4.9 \pm 0.15$

<small>THIS DRAWING IS A CONTROLLED DOCUMENT FOR THE ELECTRONICS CORPORATION IT IS SUBJECT TO CHANGE AND THE CONTROLLING ENGINEERING ORGANIZATION SHOULD BE CONTACTED FOR THE LATEST REVISION.</small>		DWN J. Jauris 01JUN01 CHK O. De Cloet 29OCT01 ZPVD H. Wendling 29OCT01	tyco Electronics AMP GmbH D - 64625 Bensheim
DIMENSIONS: mm 	TOLERANCES UNLESS OTHERWISE SPECIFIED: 0 PLC ± 0.2 1 PLC ± 0.2 2 PLC \pm 3 PLC \pm 4 PLC \pm ANGLES $\pm 2^\circ$	NAME COAXICON, CONNECTION FOR RF, GSM AND GPS PLUG FOR 120 OHM CABLE	RESTRICTED TO
MATERIAL -	FINISH -	APPLICATION SPEC - 114-71003 WEIGHT -	SIZE A3 CAGE CODE 00779 DRAWING NO. C-619059
CUSTOMER DRAWING		SCALE 10:1	SHEET 2 OF 2 REV F