

ASIC COMPANION NETWORK MOLDED WIDE BODY SOIC .295" WIDE, WITH .050" LEAD PITCH - 16 PIN

- Used in conjunction with linear technology LTC1430P6VRM
- Compliant leads for thermal expansion
- Miniaturized circuitry and packaging for spacer reduction

Model 4416P-851-001

B® Resistor Network SOIC

Electrical Characteristics

Resistance.....SEE BELOW
 Ratio Tolerance25%±2%
 Temperature Coefficient
 ±100ppm/°C
 TCR Tracking±150ppm/°C
 Temperature Range
-55°C to +125°C
 Maximum Operating Voltage
50VDC/or√ PR
 Insulation Resistance.....10,000MΩ

Product Reliability

ΔR MAX.
 Thermal Shock..... ±0.25%
 Power Condition ±0.50%
 Vibration..... ±0.25%
 Low Temperature Storage ±0.25%
 High Temperature Exposure ±0.50%
 Low Temperature Operation ±0.25%
 Load Life ±1.0%
 Moisture Resistance ±0.5%
 Resistance to Soldering Heat ±0.25%
 Short Time Overload ±0.25%

Physical Characteristics

Lead MaterialCopper, solder coated
 Body MaterialMolded epoxy
 Std. PackagingTape & reel

PACKAGE POWER TEMPERATURE DERATING CURVE

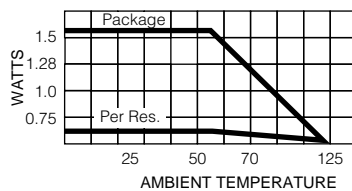

Package Power Ratings at 70°C

16 Pin1.6wattsMax.

Power Per Resistor at 70°C

.....160wattsMax.

SCHEMATIC

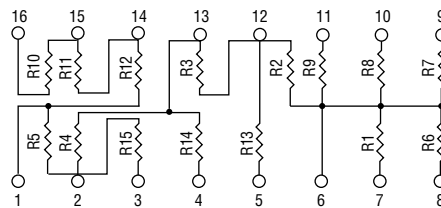

Values:

- | | |
|--------------|-----------|
| R1 - 17.6K | R10 - 1K |
| R2 - 14.2K | R11 - 33K |
| R3 - 2.11K | R12 - 33K |
| R4 - 973 | R13 - 47K |
| R5 - 13.01K | R14 - 47K |
| R6 - 27.7K | R15 - 47K |
| R7 - 55.6K | |
| R8 - 11.26K | |
| R9 - 222.58K | |

DIMENSIONS

4420P

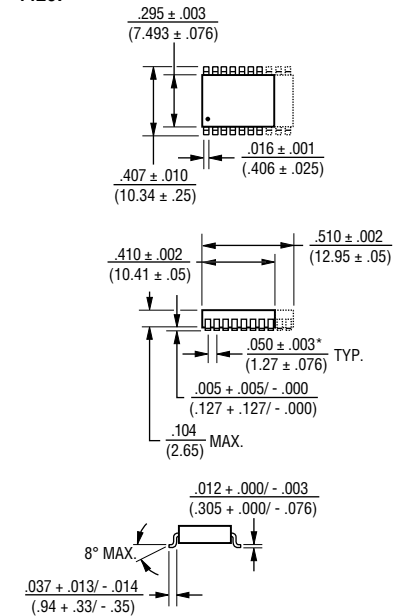

Governing dimensions are in inches. Dimensions in parentheses are metric (mm) and are approximate.

* Terminal centerline to centerline measurements made at point of emergence of the lead from the body.

TYPICAL PART MARKING

Represents total content. Layout may vary.

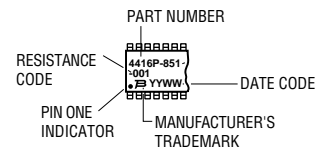

INTEGRATED TECHNOLOGIES DIVISION
 NETWORKS PRODUCTS

1400 North 1000 West
 Logan, UT 84321
 (801) 750-7200, FAX: (801) 750-7253