

REV	DATE	DESCRIPTION	BY	CHK	APP
P		REVISED PER QSB-1100-04	ALANUS	KM	SR
P1		REVISED PER ECO-96-018662	ALANUS	KM	SR
P2		ECO-97-020070	ALANUS	KM	SR
P3		REVISED PER ECO-10-000445	ALANUS	KM	REG

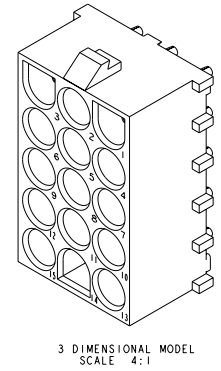

- MATES WITH HOUSING 350736.
- NOTE DELETED.
- PARTS COMPLY TO AMP SOLDERABILITY SPECIFICATION 109-11-3.
- CONTACT IS PLATED OVERALL WITH 0.00127 [0.00050] NICKEL, THEN 0.00076 [0.00030] GOLD OVER CONTACT LENGTH INDICATED AND TIN LEAD ON SOLDER TAIL END.
- CONTACT IS PLATED OVERALL WITH 0.00127 [0.00050] NICKEL, THEN 0.00038 [0.00015] GOLD OVER CONTACT LENGTH INDICATED AND TIN LEAD ON SOLDER TAIL END.
- PACKAGED PER SPEC 107-1202.
- CIRCUIT IDENTIFICATION CHARACTERS ARE ADJACENT TO THE INDICATED CAVITIES, BUT LOCATION AND ORIENTATION MAY DIFFER FROM PRINT.
- CONTACT IS PLATED OVERALL WITH 0.00127 [0.00050] NICKEL, THEN 0.00076 [0.00030] GOLD OVER CONTACT LENGTH INDICATED AND MATTE TIN ON SOLDER TAIL END.
- CONTACT IS PLATED OVERALL WITH 0.00127 [0.00050] NICKEL, THEN 0.00038 [0.00015] GOLD OVER CONTACT LENGTH INDICATED AND MATTE TIN ON SOLDER TAIL END.
- DIMENSIONS IN BRACKETS ARE IN INCHES.
- OBsolete PARTS: OBSOLETE CIS STREAMLINING PER D.RENAUD/D.SINISI

OBsolete	PHOSPOR BRONZE, PRE-TIN	NYLON, UL94V-0, NATURAL	I-350714-1
	PHOSPOR BRONZE, GOLD	NYLON, UL94V-0, NATURAL	350714-5
	PHOSPOR BRONZE, GOLD	NYLON, UL94V-0, NATURAL	350714-4
OBsolete	PHOSPOR BRONZE, GOLD	NYLON, UL94V-0, NATURAL	350714-3
	PHOSPOR BRONZE, GOLD	NYLON, UL94V-0, NATURAL	350714-2
	PHOSPOR BRONZE, PRE-TIN	NYLON, UL94V-0, NATURAL	350714-1
PIN CONTACT MATERIAL AND FINISH		HOUSING MATERIAL AND COLOR	PART NUMBER

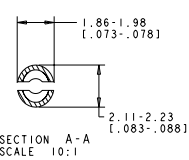
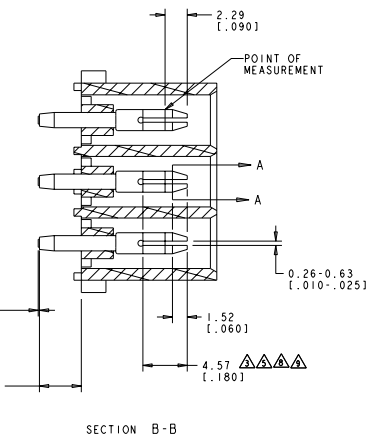
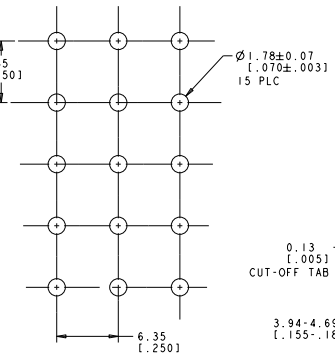
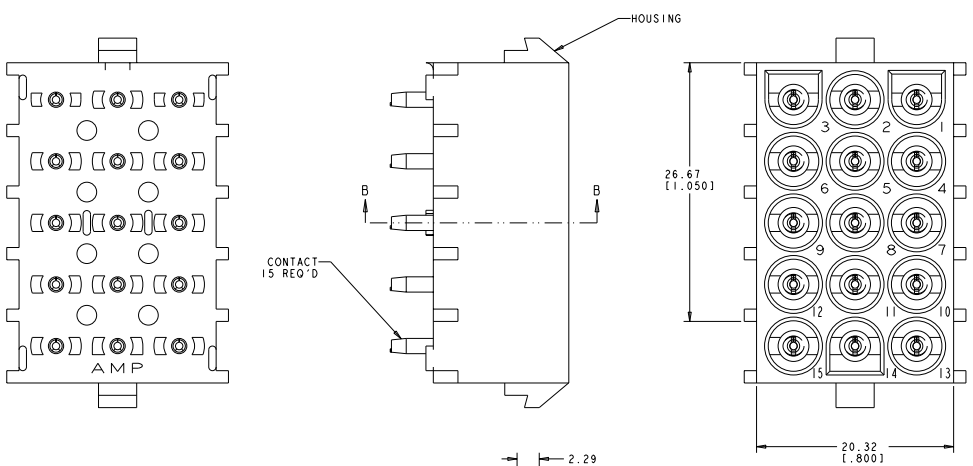

DATE: JUL 2005	REV: 00	BY: ALANUS	CHK: KM	APP: SR
DRAWING NO: 00000000		REV: 00		DATE: JUL 2005
MATERIAL: PHOSPOR BRONZE, GOLD		MATERIAL: NYLON, UL94V-0, NATURAL		DATE: JUL 2005
FINISH: PHOSPOR BRONZE, GOLD		FINISH: NYLON, UL94V-0, NATURAL		DATE: JUL 2005
SPECIFICATION: SEE TABLE		SPECIFICATION: SEE TABLE		DATE: JUL 2005
DRAWING NO: 00000000		REV: 00		DATE: JUL 2005
MATERIAL: PHOSPOR BRONZE, GOLD		MATERIAL: NYLON, UL94V-0, NATURAL		DATE: JUL 2005
FINISH: PHOSPOR BRONZE, GOLD		FINISH: NYLON, UL94V-0, NATURAL		DATE: JUL 2005
SPECIFICATION: SEE TABLE		SPECIFICATION: SEE TABLE		DATE: JUL 2005
DRAWING NO: 00000000		REV: 00		DATE: JUL 2005
MATERIAL: PHOSPOR BRONZE, GOLD		MATERIAL: NYLON, UL94V-0, NATURAL		DATE: JUL 2005
FINISH: PHOSPOR BRONZE, GOLD		FINISH: NYLON, UL94V-0, NATURAL		DATE: JUL 2005
SPECIFICATION: SEE TABLE		SPECIFICATION: SEE TABLE		DATE: JUL 2005